



 **KASTAŞ**
Hydraulic and Pneumatic Seals

All information contained in our catalogue is released only for general usage and not valid for special applications. Given parameters such as maximum pressure, temperature, sliding speed, surface contact pressure and media are determined in laboratory conditions.

In case the operating parameters are requested at maximum level, these values may not be achieved.

*Design-based system failures arising from our customers do not relate to Kastas Sealing Technologies A.S. In no event will Kastas Sealing Technologies A.S. be liable for any loss, damage, claim or expense directly or indirectly due to such defects.
For the best recommendation for a specific application you can contact our sales department.*

Kastas Sealing Technologies A.S. reserves the to make all changes and modifications. Reproduction of this catalogue or any part is strictly forbidden.



Hydraulic and Pneumatic Seals

TECHNICAL CATALOGUE

CONTENT

INTRODUCTION	3		
SEAL PROGRAMME	5		
TECHNICAL INFORMATION			
● Elastomers	12		
Thermoplastics	13		
Thermoplastic Elastomers	13		
Material Characteristics	13		
Storage of Sealing Elements	14		
General Installation Information	14		
Units, Quantities and General Tolerances	15		
HYDRAULIC SEALING ELEMENTS			
● Working Principle of Sealing Elements	18		
Choosing Sealing Elements	18		
Surface Roughness	20		
System Tolerances and Designs	22		
Permissible Sealing Gap	24		
General Installation Information	25		
Sample Designs	28		
HYDRAULIC PISTON-ROD SEALING ELEMENTS			
● Product Programme	33		
K21- Piston - Rod Seal	34		
K36- Piston - Rod Seal	48		
K95- Piston - Rod Seal	52		
KX- X-Ring	56		
HYDRAULIC ROD SEALING ELEMENTS			
● Product Programme	61		
K01- Rod Packing	62		
K04- Rod Packing	66		
K22- Rod Seal	68		
K29- Buffer Seal	74		
K31- Heavy Duty Rod Seal	76		
K32- Rod Seal	80		
K33- Rod Seal	84		
K34- Rod Seal	90		
K35- Rod Seal	92		
K37- Rod Seal	96		
K38- Rod Seal	102		
K96- Rod Seal	106		
K701- Spring Loaded Rod Seal	108		
HYDRAULIC PISTON SEALING ELEMENTS			
● Product Programme	113		
K03- Piston Packing	114		
K15- Piston Seal	116		
K16- Piston Seal	118		
K17- Piston Seal	120		
K18- Compact Piston Seal	124		
K19- Heavy Duty Piston Seal	130		
K20- Compact Piston Seal	132		
K23- Piston Seal	134		
K26- Piston Seal	140		
K40- Piston Seal	142		
K41- Piston Seal	144		
K42- Compact Piston Seal	146		
K43- Piston Seal	148		
K751- Spring Loaded Piston Seal	150		
K753 - Piston Seal	152		
WIPERS			
● Product Programme	157		
K05- Wiper	158		
K06- Wiper	160		
K07- Metal Case Wiper	166		
K07- PU Metal Case Wiper	168		
K09- Wiper	170		
K10- Double Wiper	174		
K11- Wiper	178		
K12- Metal Case Double Wiper	182		
K27- Double Wiper	184		
K703- Wiper	186		
SPECIAL SEALING ELEMENTS			
● Product Programme	191		
K 14- V-Rings	192		
K150- Chevron Ring	196		
K151- High Pressure Chevron Seal	198		
K152- Low Pressure Chevron Seal	200		
K702- Rod Seal for Rotating Applications	202		
K752- Piston Seal for Rotating Applications	204		
PNEUMATIC SEALING ELEMENTS			
● Working Principle of Sealing Elements	208		
Choosing Sealing Elements	208		
Surface Roughness	209		
System Tolerances and Designs	209		
General Installation Information	211		
Sample Designs	213		
PNEUMATIC ROD SEALING ELEMENTS			
● Product Programme	217		
K30- Pneumatic Combi Seal	218		
K51- Pneumatic Rod Seal	220		
K52- Pneumatic Rod Seal	222		
K56- Pneumatic Rod Seal	224		
K53- Pneumatic Cushioning Seal	226		
PNEUMATIC PISTON SEALING ELEMENTS			
● Product Programme	231		
K25- Pneumatic Piston Seal	232		
K50- Pneumatic Piston Seal	234		
K54- Pneumatic Piston Seal	236		
K55- Pneumatic Piston Seal	238		
K57- Pneumatic Piston Seal	240		
K58- Pneumatic Piston Seal	242		
K59- Pneumatic Piston Seal	244		
K62- Pneumatic Piston Seal	246		
K63- Pneumatic Piston Seal	248		
GUIDE ELEMENTS			
● Working Principle of Guide Elements	252		
Materials used in Guide Elements	252		
Calculation of Width & Cross Sectional Thickness	253		
Product Programme	255		
K68- Rod Guide Element	256		
K69- Piston Guide Element	262		
K73- Piston - Rod Guide Element	266		
K74- Rod Guide Ring	270		
KBT- Piston - Rod Guide Strip	272		
KKT- Piston - Rod Guide Strip	274		
KPB- Piston - Rod Guide Strip	276		
STATIC SEALING ELEMENTS			
● Product Programme	281		
K81- Back-up Ring	282		
K82- Flange Seal	286		
K83- Cover Seal	288		
K84- Cover Seal	290		
KO- O-Ring	293		
CHEMICAL RESISTANCE OF RUBBER MATERIALS	307		



YOUR PRODUCTIVITY PARTNER

Ever since the establishment of our company in 1981, the demand for our extensive range of products has steadily increased as the international market recognized the quality of our products as well as our customer service. The developments are continued with confidence and self-sacrifice keeping the indispensable principles. Fast, reliable, effective solutions are offered with high quality of products to our customers. Continuous innovations are carried through our production, in order to keep up with the globally increasing demand.

ALWAYS THE BETTER...

We value the human being, respect the environment and create differences by combining our technical knowledge with technology. We fulfill the customer expectations in means of "Business and Solution Partner" mentality. With the professional solutions and Quality Management Systems, we are becoming a global brand.

SUCCESS PROGRESS...

We provide first-class, high performance, reliable, proven standard programme and tailor-made sealing solutions for our customers worldwide. Our products are designed and produced by the latest modern manufacturing technologies with in-house compounds;

- Cylinder tests carried out during product development stage
- Highly experienced application engineers
- Compound development in our laboratory

Our commitment, know how and technical infrastructure enable us to provide quick and cost effective solutions based on your individual needs and requirements.





QUALITY AND SERVICE...

We have strengthened our company principles with quality control mechanisms that we have built up. We were certified with ISO 16949 Quality Certification in 2007.

- All the activities are managed effectively with process approach in order to achieve corporate targets
- For us, continuous improvement is not a word it's our company philosophy
- We understand the exact needs of our customers and personnel in order to maintain the continuity of customer satisfaction
- We create the necessary environment for our employees to use their capabilities in accordance with corporate targets
- We create common objectives and work in harmony with our suppliers in order to develop their competency

Quality is being perceived as a life philosophy and controlled periodically in order for system continuity.

WORLD INDUSTRY TRUST ON KASTAŞ...

We are pleased to share our long years of experience gained in manufacturing hydraulic and pneumatic sealing elements to fulfill the expectations of our customers with utmost care. We are proud of being among the largest recognized companies in our field.

We have established Kastas Kaucuk Europe GmbH in Hamburg, Germany in the beginning of 2009 to be closer to our customers located in North and Western Europe. We are much closer to our customers in Europe now...



SEAL PROGRAMME

KASTAS CODE	PRODUCT NAME	DRAWING	APPLICATION	MATERIAL	CODE	PRESSURE (max) bar	TEMPERATURE (max) °C	SLIDING SPEED (max) - m/sec	PAGE
KO	O-Ring		Rod Piston	NBR	NB7001	63	-30/+105	0.5	293
KX	X-Ring		Rod Piston	NBR	NB7001	50	-30/+105	0.5	56
K01	Rod Packing		Rod	NBR FABRIC NBR POM	NB9001 NB8008 PM9903	400	-30/+105	0.5	62
K03	Piston Packing		Piston	FABRIC NBR POM	NB8008 PM9903	400	-30/+105	0.5	114
K04	Rod Packing		Rod	NBR FABRIC NBR POM	NB9001 NB8008 PM9903	400	-30/+105	0.5	66
K05	Wiper		Rod	PU	PU9501		-30/+100	1.0	158
K06	Wiper		Rod	NBR PU	NB9001 PU9201		-30/+105 -30/+100	1.0 1.0	160
K07 NBR	Metal Case Wiper		Rod	NBR STEEL	NB9001 FE9901		-30/+105	1.0	166
K07 PU	Metal Case Wiper		Rod	PU STEEL	PU9201 FE9901		-30/+100	1.0	168
K09	Wiper		Rod	NBR PU	NB9001 PU9201		-30/+105 -30/+100	1.0 1.0	170
K10	Double Wiper		Rod	NBR	NB9001		-30/+105	1.0	174
K11	Wiper		Rod	TPE	TP5501		-40/+120	2.0	178
K12	Metal Case Double Wiper		Rod	PU STEEL	PU9501 FE9901		-30/+100	1.0	182
K14	V-Ring			NBR	NB7001	0.3	-30/+105	12.0 Peripheral	192
K15	Piston Seal		Piston	NBR PU	NB7001 PU9501	250	-30/+100	0.5	116













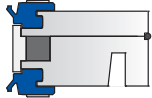

SEAL PROGRAMME

KASTAS CODE	PRODUCT NAME	DRAWING	APPLICATION	MATERIAL	CODE	PRESSURE (max) bar	TEMPERATURE (max) °C	SLIDING SPEED (max) - m/sec	PAGE
K16	Compact Piston Seal		Piston	NBR FABRIC NBR POM	NB8001 NB8008 PM9901	400	-30/+105	0.5	118
K17	Piston Seal		Piston	NBR PTFE	NB7001 PT6003	400	-30/+105	5.0	120
K18	Compact Piston Seal		Piston	NBR TPE POM	NB8001 TP7301 PM9901	400	-30/+105	0.5	124
K19	Heavy Duty Piston Seal		Piston	NBR PTFE POM	NB8001 PT6003 PM9901	400	-30/+105	1.50	130
K20	Compact Piston Seal		Piston	NBR POM	NB8001 PM9901	150	-30/+105	0.5	132
K21	Rod Piston Seal		Piston Rod	NBR PU	NB9001 PU9201	150 400	-30/+105 -30/+100	0.5 0.5	34
K22	Rod Seal		Rod	NBR PU	NB9001 PU9201	150 400	-30/+105 -30/+100	0.5 0.5	68
K23	Piston Seal		Piston	NBR PU	NB9001 PU9201	150 400	-30/+105 -30/+100	0.5 0.5	134
K25	Pneumatic Piston Seal		Piston	NBR STEEL	NB7501 FE9901	16	-30/+105	1.0	232
K26	Piston Seal		Piston	NBR STEEL SPRING	NB9001 FE9901 CN9901	60	-30/+105	0.5	140
K27	Double Wiper		Rod	NBR PU	NB9001 PU9201		-30/+105 -30/+100	1.0 1.0	184
K29	Buffer Seal		Rod	PU POM	PU9201 PM9901	400	-30/+100	0.5	74
K30	Pneumatic Combi Seal		Rod	NBR STEEL	NB7001 FE9901	16	-30/+105	1.0	218
K31	Heavy Duty Rod Seal		Rod	NBR PU POM	NB7001 PU9401 PM9901	630	-30/+100	0.5	76
K32	Rod Seal		Rod	PU POM	PU9401 PM9901	400	-30/+100	0.5	80

SEAL PROGRAMME

KASTAS CODE	PRODUCT NAME	DRAWING	APPLICATION	MATERIAL	CODE	PRESSURE (max) bar	TEMPERATURE (max) °C	SLIDING SPEED (max) - m/sec	PAGE
K33	Rod Seal		Rod	PU	PU9401	400	-30/+100	0.5	84
K34	Rod Seal		Rod	NBR FABRIC NBR TPE POM	NB8001 NB8008 TP5501 PM9901	700	-30/+105	0.5	90
K35	Rod Seal		Rod	NBR PTFE	NB7001 PT6003	400	-30/+105	5.0	92
K36	Piston Rod Seal		Piston Rod	NBR FABRIC NBR	NB8001 NB8008	250	-30/+105	0.5	48
K37	Rod Seal		Rod	NBR FABRIC NBR POM	NB8001 NB8008 PM9901	400	-30/+105	0.5	96
K38	Rod Seal		Rod	PU	PU9401	400	-30/+100	0.5	102
K40	Piston Seal		Piston	PU POM	PU9401 PM9901	400	-30/+100	0.5	142
K41	Piston Seal		Piston	NBR PTFE	NB7001 PT6003	400	-30/+105	5.0	144
K42	Compact Piston Seal		Piston	NBR TPE POM	NB8001 TP5501 PM9901	700	-30/+105	0.5	146
K43	Piston Seal		Piston	NBR FABRIC NBR POM	NB8001 NB8008 PM9901	500	-30/+105	0.5	148
K50	Pneumatic Piston Seal		Piston	NBR PU	NB8001 PU8001	12 16	-30/+105 -30/+80	1.0 1.0	234
K51	Pneumatic Rod Seal		Rod	PU	PU9201	16	-30/+80	1.0	220
K52	Pneumatic Rod Seal		Rod	NBR PU	NB9001 PU9201	12 16	-30/+105 -30/+80	1.0 1.0	222
K53	Pneumatic Cushioning Seal		Rod	NBR PU	NB9001 PU9201	12 16	-30/+105 -30/+80	1.0 1.0	226
K54	Pneumatic Piston Seal		Piston	NBR	NB7001	12	-30/+105	1.0	236

SEAL PROGRAMME

KASTAS CODE	PRODUCT NAME	DRAWING	APPLICATION	MATERIAL	CODE	PRESSURE (max) bar	TEMPERATURE (max) °C	SLIDING SPEED (max) - m/sec	PAGE
K55	Pneumatic Piston Seal		Piston	NBR ALUMINUM	NB7001 AL9901	12	-30/+105	1.0	238
K56	Pneumatic Rod Seal		Rod	NBR TPE	NB8001 TP5501	16	-30/+105	1.0	224
K57	Pneumatic Piston Seal		Piston	NBR ALUMINUM	NB7001 AL9901	12	-30/+105	1.0	240
K58	Pneumatic Piston Seal		Piston	PU POM ALUMINUM MAGNET NBR	PU9201 PM9901 AL9901 MK9901 NB7001	12	-30/+80	1.0	242
K59	Pneumatic Piston Seal		Piston	NBR PU	NB8001 PU8001	12 16	-30/+105 -30/+80	1.0 1.0	244
K62	Pneumatic Piston Seal		Piston	NBR	NB7001	12	-30/+105	1.0	246
K63	Pneumatic Piston Seal		Piston	NBR	NB7001	12	-30/+105	1.0	248
K68	Rod Guide Ring		Rod	POM	PM9902		-30/+125	1.0	256
K69	Piston Guide Ring		Piston	POM	PM9902		-30/+125	1.0	262
K73	Piston Rod Guide Ring		Piston Rod	POLYESTER RESIN	PR6501		-40/+120	1.0	266
K74	Rod Guide Ring		Rod	POM	PM9902		-30/+125	1.0	270
K81	Back-up Ring		Piston Rod	TPE	TP5501	500	-40/+120	1.0	282
K82	Flange Seal			PU	PU9401	600	-30/+100		286
K83	Cover Seal			PU	PU9401	600	-30/+100		288
K84	Cover Seal			PU	PU9401	600	-30/+100		290

SEAL PROGRAMME

KASTAS CODE	PRODUCT NAME	DRAWING	APPLICATION	MATERIAL	CODE	PRESSURE (max) bar	TEMPERATURE (max) °C	SLIDING SPEED (max) - m/sec	PAGE
K95	Piston Rod Seal		Piston Rod	NBR	NB9001	150	-30/+105	0.5	52
K96	Rod Seal		Rod	NBR	NB9001	150	-30/+105	0.5	106
K150	Chevron Ring		Rod	FABRIC NBR	NB8503	250	-30/+80	2.0	196
K151	High Pressure Chevron Seal		Rod	FABRIC NBR POM PTFE	NB8503 PM9901 PT6002	250	-30/+80	2.0	198
K152/ K153	Low Pressure Chevron Seal		Rod	FABRIC NBR POM	NB8503 PM9901	80	-30/+80	2.0	200
K701	Spring Loaded Rod Seal		Rod	PTFE V-SPRING	PT6002 CN9902	350	-150/+250	15.0	108
K702	Rod Seal for Rotating Application		Rod	NBR PTFE	NB7001 PT6003	300	-30/+105	5.0 Peripheral	202
K703	Wiper		Rod	NBR PTFE	NB7001 PT6003		-30/+105	5.0	186
K751	Spring Loaded Piston Seal		Piston	PTFE V-SPRING	PT6002 CN9902	350	-150/+250	15.0	150
K752	Piston Seal for Rotating Application		Piston	NBR PTFE	NB7001 PT6003	300	-30/+105	5.0 Peripheral	204
K753	Piston Seal		Piston	NBR PTFE	NB7001 PT6003	400	-30/+105	2.0	152
KBT	PTFE Bronze Guide Strip		Piston Rod	PTFE	PT6003		-60/+200	15.0	272
KKT	Carbon PTFE Guide Strip		Piston Rod	PTFE	PT6002		-60/+200	15.0	274
KPB	Polyester Resin Guide Strip		Piston Rod	POLYESTER RESIN	PR6501		-40/+120	1.0	276



20 horizontal light gray lines for writing.

A blue 3D ring is positioned in the lower-left quadrant of the page, appearing to float over a background of numerous water droplets of various sizes. The droplets are rendered with realistic highlights and shadows, giving them a three-dimensional appearance. The background is a light, neutral color, which makes the droplets stand out. The ring is a simple, solid blue band with a slight thickness and a smooth finish. A horizontal grey bar is located below the ring, containing the text 'TECHNICAL INFORMATION'.

TECHNICAL INFORMATION

HISTORY OF RUBBER

The first type of the rubber used in the world is the natural rubber and it is obtained from the resin by crosswise cutting of the rubber tree. Commercial usage of the natural rubber started in 1736 with moving from South America to France. During the early applications in England, it was seen that the natural rubber was able to erase the lead pencil and this material was named as "rubber" in the meaning of rubbing.

Charles Goodyear managed to vulcanize rubber and sulphur. The First World War proved that rubber was a strategic compound and increasing needs caused the invention of synthetic rubber obtained from the derivatives of petroleum.

ELASTOMERS

NITRILE-BUTADIENE RUBBER (NBR)

It is been recommended for the most part of the sealing elements applications and it has a very common use. Nitrile (NBR) is a Butadiene-Acrylo Nitrile (ACN) polymer. At Kastaş the percentage of Acrylo nitrile in the nitrile compound varies between 30% and 50%. The variation in the percentage of ACN changes the volume, gas permeability, elasticity and compression set of the compound used in mineral oils, grease and fuel. Nitrile is very durable against aliphatic hydrocarbons (i.e. propane, butane, petroleum, etc), mineral oils (lubricants, H, HL, HLP type of hydraulic oils), greases, HFA, HFB, HFC, vegetal-animal oils, light heating oil and diesel oil. For fuels and industrial fluids, different mixtures are prepared. Our standard nitrile compound is recommended to be used between 30°C, +105°C. For short period of time, it can be increased to +120 °C. With special additives to increase the lowest temperature resistance the nitrile compound can be used up to -40°C. The compression set of nitrile rubber is very good so it is been widely used as sealing elements.

HYDROGENATED NITRILE-BUTADIENE RUBBER (HNBR)

It is a kind of elastomer which is made in a way that a part or the complete part of NBR polymer is hydrogenised with double linked Butadiene. Vulcanized with peroxide, HNBR has durability against high temperature and oxidation. Having higher temperature resistance and mechanical properties than standard NBR compound, HNBR is recommended to be used between -30°C and 150°C. It has wide range of use especially in automotive sector and special applications in mobile hydraulics.

SILICONE (MVQ)

Silicone keeps its elasticity between -60°C and 200°C. It is not recommended to be used in dynamic applications. It has good resistance to ozone, air and grease. With special additives to increase the lowest temperature resistance MVQ compound can be used up to -90°C. It has less durability against oxidizing lubricants, some hipoints and lubricants of E.P. type.

FLUOROELASTOMER (FKM)

This material under the trademark Viton or Florel has less durability against all types of greases, lubricants and solvents. It has very good resistance against many chemicals. It gives good results in vacuum systems due to the low gas permeability. Mechanical properties and the temperature range can be improved with special additives. It has very low resistance to steam, hot water, methanol and other polar solvents. FKM can be used between -30°C and 225°C.

POLYCHLOROPRENE (CR)

This material under the trademark Neoprene has good resistance to rupture, tear and wearing out between the temperatures -45°C and 100°C. It has durability to flame. Its resistance against mineral oils with high aniline point, silicone oil, greases and alcohol is good. It is also being used in applications where durability for lubricants and atmospheric conditions are required.

POLYURETHANE (PU)

It is widely used in the sealing elements due to the improvements on the compression set property over the last 15 years. It has perfect durability against rupture, tear and wearing out between the temperatures -30°C and 100°C. Its resistance to mineral oils, grease and aliphatic hydrocarbon is good. Its resistance to polar solvents, aromatics, brake fluids, acid and alkaline is not very good. Especially, it is used as a shaft stripper and high pressurized sealing element.

ETHYLENE-PROPYLENE DIENE RUBBER (EPDM)

It can be used between the temperatures -40°C and 145°C. It has very good resistance to brake fluids, ester based lubricants, hot water and steam.

STYRENE BUTADIENE RUBBER (SBR)

Between the temperatures -50°C and 100°C, its resistance against glycol based brake fluids, inorganic/organic acids and alcohol is good.

NATURAL RUBBER (NR)

It is used between the temperatures -60°C and 100°C. It is recommended in applications where high flexibility is required.

THERMOPLASTICS

POLYTETRAFLUOROETHYLENE-PTFE

This material is known as Teflon, the trademark of DUPONT Company. PTFE material does have the lowest coefficient of friction. Due to the low friction coefficient and high wear resistance, it performs well on poorly lubricating conditions as well as high sliding speeds. PTFE can be used in temperatures between -200°C to +260°C. It has very good resistance to all chemicals except alkaline metals, high pressure-temperature chlorotrifluor and basic fluorines. Hardness and elasticity make the material to be used widely in hydraulic applications. Depending onto the application; glass, graphite, carbon, MoS₂ and bronze filled PTFE can be used to increase mechanical and physical properties. The influence of the hydraulic media, the behavior in contact with the counter surface and the form stability depending on the operating temperature are the important properties when selecting the PTFE compound among the others.

POLYAMIDE-PA

This material is known as Nylon 6. It can be used in temperatures between -30°C to +120°C, for short period of applications this can be increased up to +140°C. Polyamide is able to work on poorly lubricating conditions and does have high wear resistance. It is commonly used as guiding elements in hydraulic and pneumatic systems. Special additives can increase the mechanical and physical properties of the material depending on the application.

POLYOXYMETHYLENE - POLYACETAL (POM)

It has excellent form stability between temperatures -40°C to +100°C, for short period of applications this can be increase up to +140°C. It is commonly used as guide and backup rings in hydraulic and pneumatic systems. It is being safely used in mineral oils, HFA and HFB type of oils. For the guide ring, glass filled POM is used due to its high contact pressure value.

THERMOPLASTIC ELASTOMERS

THERMOPLASTIC POLYESTER ELASTOMER (TPE)

Polyester Elastomers are widely used as backup ring and header ring material with the sealing elements in hydraulic and pneumatic systems due to their chemical structure. It has excellent resistance to hydraulic oils and has high extrusion resistance compared to the other materials. It can be used in temperatures between -40°C to 120°C.

CHARACTERISTIC PROPERTIES OF RUBBER MATERIALS

Physical Properties	NBR	HNBR	FKM	MVQ	EPDM	CR	SBR	NR	PU	PTFE	TPE	POM
TENSILE STRENGTH	3	2	4	6	4	3	1	1	1	5	5	5
ELONGATION AT BREAK	2	2	3	4	3	2	1	1	1	5	5	5
FLEXIBILITY	2	2	4	3	3	3	1	1	2	5	5	5
WEAR RESISTANCE	2	2	4	5	3	2	2	2	1	1	1	1
TEAR RESISTANCE	3	2	3	6	3	2	2	2	1	1	1	1
AGING RESISTANCE	3	2	1	1	1	2	3	3	2	1	3	3
OZONE RESISTANCE	3	3	1	1	1	2	4	4	2	1	3	3
FUEL RESISTANCE	1	1	1	5	5	2	6	6	6	1	2	2
GREASE&HYDRAULIC OIL RESISTANCE	1	1	1	3	4	3	6	6	1	1	1	1
ACID RESISTANCE	4	4	1	5	1	2	3	3	6	1	4	4
ALCALI RESISTANCE	3	3	1	5	2	2	3	3	6	1	4	4
HOT WATER RESISTANCE	3	3	4	5	2	3	3	3	3	1	3	3
MAX. OPERATING TEMPERATURE	105	150	225	200	145	100	100	100	100	260	120	110
MIN. OPERATING TEMPERATURE	-30	-30	-30	-60	-40	-45	-50	-60	-30	-200	-40	-40

1 Excellent 2 Very good 3 Good 4 Medium 5 Low 6 Poor

STORAGE OF SEALING ELEMENTS

The mechanical and physical properties of sealing elements produced from elastomers, thermoplastics and thermoplastic elastomers can change. This could be caused by many factors such as;

- Oxygen
- Ozone
- Direct sun light
- High temperature
- Ultra-violet rays
- Humidity
- Dirt and chemical effects

The sealing elements produced from elastomers, thermoplastics and thermoplastic elastomers do not change any mechanical or physical properties if not exposed to the above mentioned conditions.

ENVIRONMENT, HUMIDITY AND TEMPERATURE

The ideal storage temperature should be between 5°C to 25°C with a humidity of 60%. Lower temperatures do not affect the mechanical properties but before installation we recommend to have the temperature for sealing element to be 20-25°C. In addition to these, direct heat source contacts should be avoided.

DIRT

It may change the mechanical properties of the products. Therefore, the environment should be cleaned before installation and during storage.

LIGHT AND ULTRAVIOLET RAYS

It is recommended to have the storage rooms protected from Fluorescent lamp, ultraviolet rays, powerful light sources and direct sun light. Red or orange colour lights should be preferred.

OXYGEN AND OZONE

These two elements are oxidizing agents. It is recommended to store the seals in the packages that are produced from Polyethylene (PE) material. Ozone is especially a destructive agent so there should not be electrical equipments with high voltages such as motors, etc.

DEFORMATION

Deformation should be avoided during storage. Sealing elements produced from elastomers, thermoplastics and thermoplastic elastomers should be kept away from coercive forces and squeezing as these might cause changes in the mechanical and physical properties of the products.

GREASES AND CONTACT WITH THE HYDRAULIC FLUID

Any contact with solvents, oils and other fluids should be avoided during the storage of the products.

CONTACT WITH METALS

Some metals (e.g. Manganese, Copper) may harm some sealing elements; therefore, contacting directly with metals or their alloys should be avoided.

GENERAL INSTALLATION INFORMATION

Installation information is one of the important factors for hydraulic and pneumatic sealing elements to have a long life span and work without any problem. The installation information that is given in each product page and other general information can be summarized as;

- Installation area and the table should be clean. There should not be any foreign substances.
- Before installation the complete system must be cleaned to remove machining residues, chips, dirt and other particles. Sharp edges must be de-burred or chamfered or radiused.
- To prevent damage to the sealing elements when mounting, cylinder bores, piston rods must be chamfered
- The sealing elements should be cleaned prior to the installation
- All the sealing elements should be oiled with system oil before installation. Using grease should be avoided or a grease type that does not go into the reaction with the sealing element should be chosen.

- Sharp-edged installation tools should not be used.
- It is very dangerous to have uncontrolled heating of sealing elements prior to the installation
- If there is an operation (i.e. painting) after the testing of the cylinder we recommend the temperature not to go above 70°C.

For the installation of hydraulic sealing elements please see section; Hydraulic Sealing Elements - General Installation Information.

For the installation of pneumatic sealing elements please see section; Pneumatic Sealing Elements - General Installation Information.

UNIT, QUANTITY AND GENERAL TOLERANCES

FURTHER OFFICIAL DERIVED UNITS IN MECHANICS

QUANTITY	UNITS	OFFICIAL UNITS ALSO USED
Angular momentum	N . m . s	
Torque	Nm	
Revolutions per minute	2 . x . rad / s	s ⁻¹
Modulus of elasticity	Pa	N / mm ² , bar
Enthalpy	J	Kj
Specific enthalpy	J / kg	kJ / kg
Entropy	J / K	kJ / K
Specific entropy	J / kg . K	kJ / kg . K
Geometrical moment of inertia	m ⁴	cm ⁴
Force	N	kN, MN
Gas constant	J / kg . K	kJ / kg . K
Calorific value	J / kg, J / m ³	kJ / kg, kJ / m ³
Momentum	N . s	
Mass moment of inertia	kg . m	g . m, t . m ²
Moment	N . m	
Unit conductance	W / m . K ⁴	
Volume specific	m ³ / kg	
Coefficient of heat transfer	W / m . K	
Heat capacity	J / K	kJ / K
Heat capacity specific	J / kg . K	kJ / kg . K
Thermal conductivity	W / m . K	
Section modulus	m ³	cm ³

CONVERSION TABLE

FORCE 1 Newton (N) = 1 kg m/s ²				ENERGY, WORK, AMOUNT OF HEAT Nm = 1 Joule (J) = 1 Ws					POWER 1 Watt (W) = 1 Nm/s = 1 J/s			
N	kp	dyn		Nm	kWh	kpm	cal		W	kW	PS	
1 N	1	0.102	10 ⁵	1 Nm	1	0.278x10 ⁻⁶	0.102	0.238	1 W	1	10 ⁻³	1.36x10 ⁻³
1 kp	9.81	1	9.81x10 ⁵	1 kWh	3.6x10 ⁶	1	0.367x10 ⁶	0.86x10 ⁶	1 kW	10 ³	1	1.36
1 dyn	10 ⁻⁵	1.02x10 ⁻⁶	1	1 kpm	9.81	2.72x10 ⁻⁶	1	2.335	1 PS	736	0.736	1
				1 cal	4.19	1.17x10 ⁻⁶	0.428	1				

PRESSURE MECHANICAL STRESS

1 Pascal (Pa) = 1 N/m²; 1 Mpa (106 Pa) = 1 N/mm² = 0.102 kp/mm²

	Pa	MPa	bar	kp / cm ²	mm Hg	atm	mWs
1 Pa=1 N/m ²	1	10 ⁻⁶	10 ⁻⁵	1.02x10 ⁻⁵	7.50x10 ⁻³	9.87x10 ⁻⁶	1.02x10 ⁻⁴
1 Mpa=1 N/mm ²	10 ⁶	1	10	10.2	7.50x10 ³	9.87	102
1 bar	10 ⁵	0.10	1	1.02	750	0.987	10.2
1 kp/cm ² (at)	9.81x10 ⁴	9.81x10 ⁻²	0.981	1	736	0.968	10
1 mm Hg (Torr)	133	1.33x10 ⁻⁴	1.33x10 ⁻³	1.36x10 ⁻³	1	1.32x10 ⁻³	1.36x10 ⁻²
1 atm	1.013x10 ⁵	0.1013	1.013	1.033	760	1	10.33
1 mWs	9.81x10 ³	9.81x10 ⁻³	9.81x10 ⁻²	0.1	73.6	9.68x10 ⁻²	1

TOLERANCES FOR MACHINED PARTS OF THERMOPLASTICS

NOMINAL DIMENSION	TOLERANCES ACCORDING TO DIN 7168 "MEDIUM"	RESTRICTED WORKING TOLERANCES
≤ 6	±0.1	0.10
6 < ≤30	±0.2	0.15
30 < ≤65	±0.3	0.20
65 < ≤120	±0.3	0.30
120 < ≤200	±0.5	0.40

Extract from DIN 7168.

TOLERANCES FOR ELASTOMERS

NOMINAL DIMENSION	CLASS M1		CLASS M2		CLASS M3		CLASS M4	
	F	C	F	C	F	C	F	C

Permissible deviations of dimensions in mm.

≤ 6.3	±0.10	±0.10	±0.15	±0.20	±0.25	±0.40	±0.50	±0.50
6.3 < ≤10	±0.10	±0.15	±0.20	±0.20	±0.30	±0.50	±0.70	±0.70
10 < ≤16	±0.15	±0.20	±0.20	±0.25	±0.40	±0.60	±0.80	±0.80
16 < ≤25	±0.20	±0.20	±0.25	±0.35	±0.50	±0.80	±1.00	±1.00
25 < ≤40	±0.20	±0.25	±0.35	±0.40	±0.60	±1.00	±1.30	±1.30
40 < ≤63	±0.25	±0.35	±0.40	±0.50	±0.80	±1.30	±1.60	±1.60
63 < ≤100	±0.35	±0.40	±0.50	±0.70	±1.00	±1.60	±2.00	±2.00
100 < ≤160	±0.40	±0.50	±0.70	±0.80	±1.30	±2.00	±2.50	±2.50

Permissible deviations in %.

160 <	0.30		0.50		0.80		1.50	1.50
-------	------	--	------	--	------	--	------	------

Extract from ISO 3302-1.

HYDRAULIC SEALING ELEMENTS



WORKING PRINCIPLE OF SEALING ELEMENTS

Hydraulic cylinders are being used in mechanical applications where reciprocating forces and movements are needed. Sealing element is one of the most important parts of the cylinders. The sealing elements are being installed into the respective groove with a preload. Figure 1 shows the sealing element in free state, preload after the assembly of the seal and the free space needed in the housing.

The sealing element is able to work in low pressures due to this preload. Figure 2 shows the pressurized media filling into the groove and sealing element is expanded with this pressure. Sealing elements are produced from such materials that can change their form when force is applied (Figure 2) and can return to the original form when this force disappears (Figure 1). In this respect sealing elements are produced from elastomers, thermoplastics or thermoplastic elastomers.

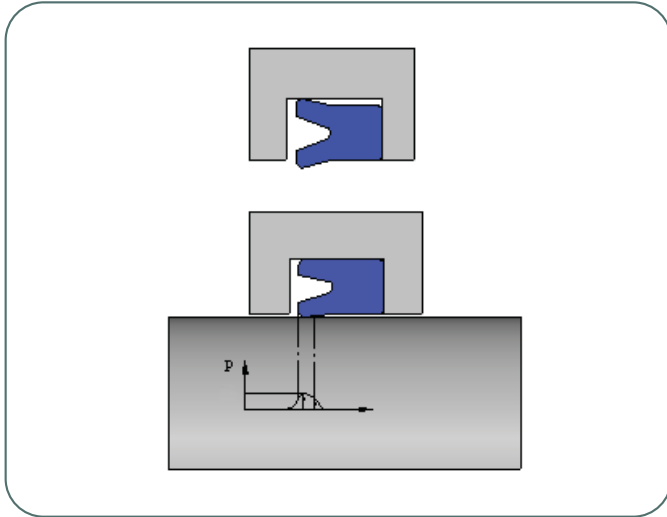

Figure 1
Sealing element in free state

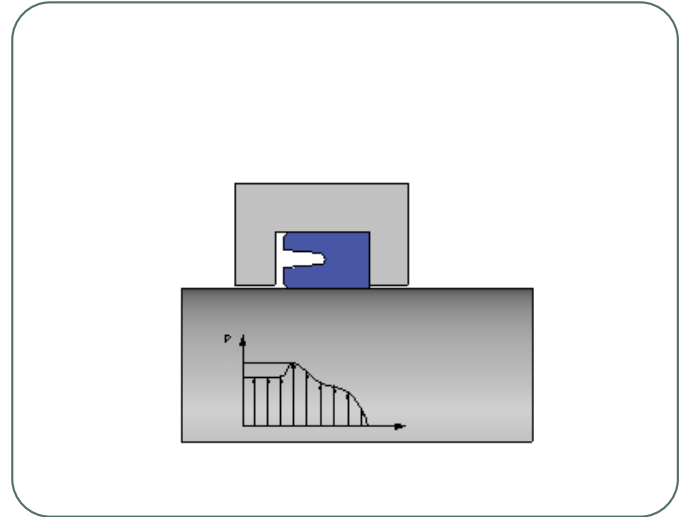

Figure 2
Sealing element under pressure

CHOOSING SEALING ELEMENTS

System pressure, sliding speed, temperature, media, surface roughness and system tolerances are the important parameters when choosing the type of the sealing element.

PRESSURE

The first important feature that should be looked at in the system is the pressure, because the system working force is obtained by the cylinder bore diameter and the system pressure. While calculating the system pressure we recommend to take the shock pressures into consideration which are generally higher than the normal operating pressures. Nowadays the demand for higher forces made the system pressures increase in the hydraulic systems. That is why there are new profiles with new engineering materials in the sealing elements. Kastaş offers sealing solutions that can go up to 700 bar. Operating pressure of the sealing elements can be seen in Product Programme.

TEMPERATURE

The media and the working temperature are two most important factors in choosing the material for sealing elements. The ideal working temperature for sealing element and system is 50°C, but the application temperature usually goes up to 100°C. In dynamic applications, sealing elements do have direct contact with the sliding surface and that is why they have been effected by the heat originated from the friction forces. The system temperature should be less than the working temperature of the sealing element. Table 1 shows the maximum operating temperatures of the sealing elements. For special applications that require high temperatures, we recommend sealing elements produced from FKM and/or PTFE material. For low temperatures, it is believed that the sealing elements become harder (glass transition) and will not do the required job, but actually depending on the media the sealing elements are able to work without any problems up to -40°C. The operating temperatures for the sealing elements can be seen in Product's Programme.

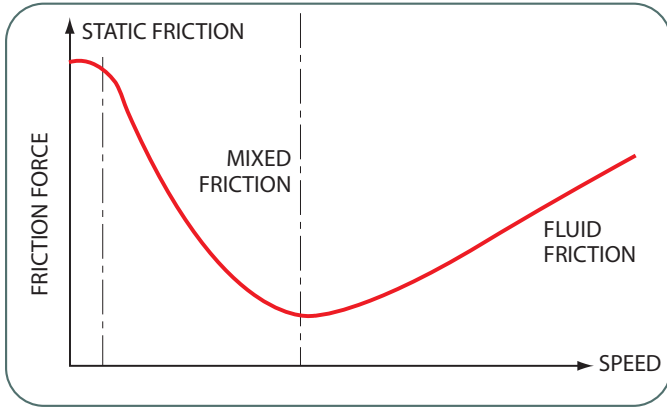

Figure 3
Friction force vs Sliding Speed

SPEED

The speed of the cylinder can go up to 15 m/sec depending on the material of the sealing element, design and the application. Speed is one of the important features which defines the oil film generation and the friction forces. Figure 3 shows increasing of the friction forces with speed increasing and oil film thickness decreasing. That is why at high sliding speeds the sealing elements should be chosen from PTFE material. The sliding speed for the sealing elements can be seen in our Product Programme.

MEDIA

The minimum and maximum operating temperature of the sealing elements do change with the media they are being used in. Sealing elements can be used in mineral oils (DIN 51524), non flammable hydraulic oils (VDMA 24317 or DIN 24320), atmosphere, water and different type of media (See section; Chemical Resistance of Rubber Materials). Table 1 shows the most common media used with the sealing elements.

The viscosity of the media is one of the reasons of wear in the sealing elements. Pressure and temperature change the viscosity of the media. The viscosity of the media increases with the pressure. Increasing temperature reduces the viscosity of the media (this change depends on the media type). The effect of operating pressure and temperature on the viscosity should be investigated when choosing the media type.

OPERATING TEMPERATURE OF THE MATERIALS USED FOR SEALING ELEMENTS

Material	Operating Temp.	STANDARD KASTAŞ COMPOUNDS				Mineral Oils	Air	Water
		Non-Flammable Hydraulic Oils						
		HFA	HFB	HFC	HFD			
80 NBR	-30	55	60	60	-	105	105	90
70 NBR	-35	55	60	60	-	105	105	90
90 NBR	-30	55	60	60	-	105	105	90
90 FKM	-25	55	60	60	150	225	200	80
70 FKM	-30	55	60	60	150	225	200	80
80 PU	-30	40	40	40	-	80	80	40
92 PU	-30	40	40	40	-	100	80	40
POM	-40	55	60	60	80	125	100	90
PTFE	-80	-	-	-	150	200	200	150
Polyester Elastomer	-30	40	40	40	-	100	80	40

Table 1
Operating temperature of the materials used for sealing elements 19



SURFACE ROUGHNESS

The surfaces that the sealing elements will be working should be honed, grinded and polished. Surface roughness should be according to the catalogue information of the respective sealing element. Figure 4 shows the schematic of sealing element material matching with the surface roughness values. As it is seen in Figure 4, rubber materials can adapt with the irregularities of the surface; on the other hand PTFE material adaptation is not as good as the other sealing materials.

Ra value that we indicate in our catalogue is the arithmetic average of the absolute roughness values in specific length of surface (Figure 5).

$$R_a = \frac{1}{L_t} \int_0^{L_t} |z(x)| dx$$

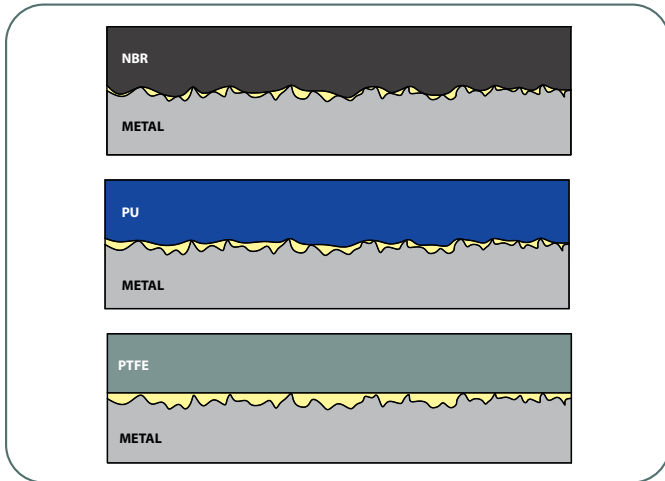

Figure 4
Sealing edge in contact with counter surface

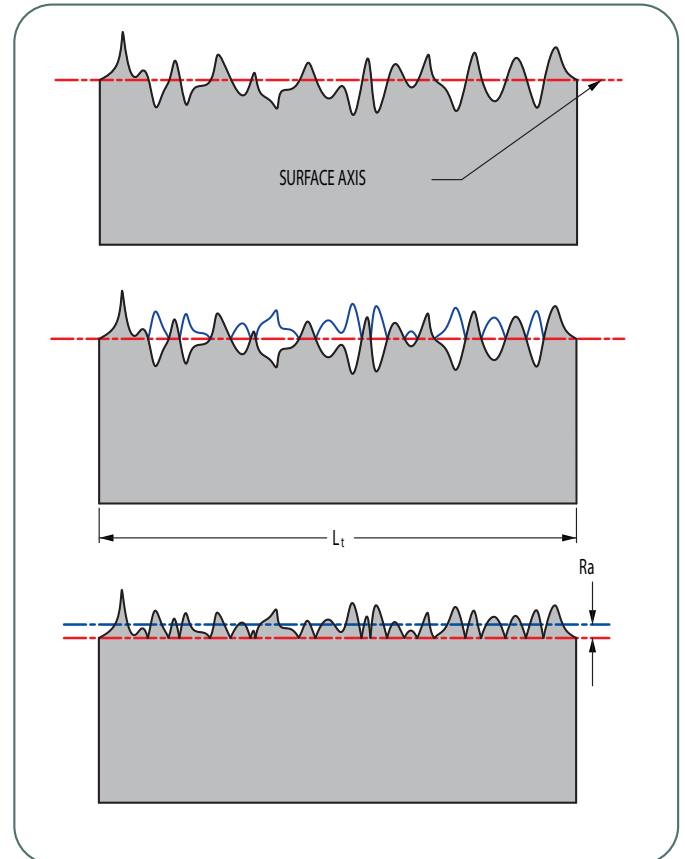

Figure 5
Calculation of Ra surface roughness value

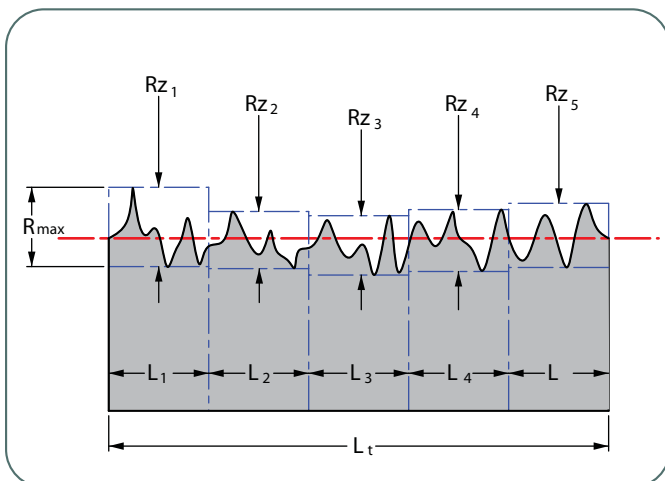
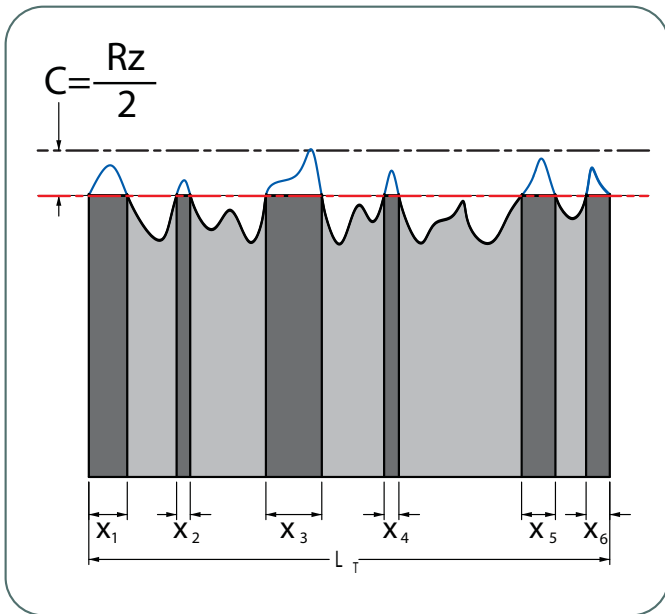

Figure 6
Rz surface roughness value and calculation of Rmax

$$R_z = \frac{R_{z1} + R_{z2} + R_{z3} + R_{z4} + R_{z5}}{5}$$

Rz value that we indicate in our catalogue is the average of the 5 consecutive maximum roughness values in specific length of surface, Rmax is the maximum of these values (Figure 6).



$$Rmr = \frac{X_1 + X_2 + X_3 + X_4 + X_5 + X_6}{L_T} \times 100$$

During the working of the sealing element average surface contact area does have an important role besides the Ra and Rz values. Surface contact area Rmr is the ratio of surface roughness cutted with C depth and the proportion of the contact surface areas to non contact surface areas in the specific surface length. Kastaş supplies Rmr values in the catalogue in order to maximize the performance of the sealing elements according to $C=Rz/2$ (Figure 7).

Figure 7
Calculation of Rmr surface roughness ratio

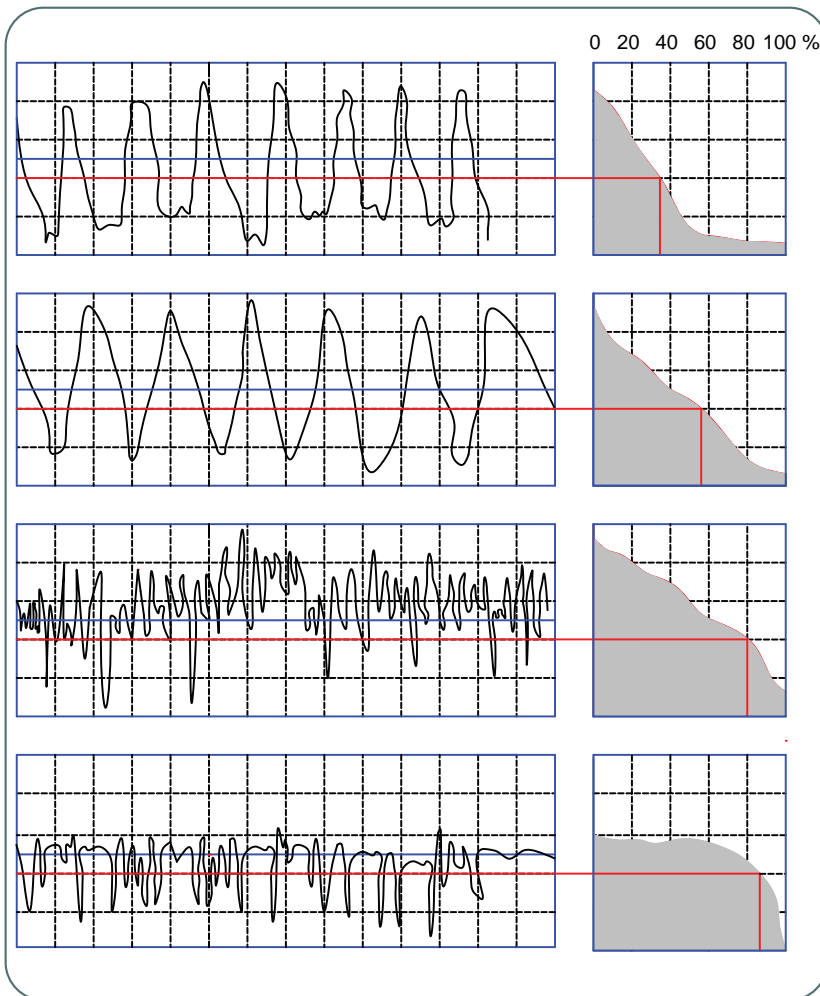

As it can be seen from the above graphs, similar values of Rmax at depth C, we see that Rmr value varies between 35% and 90%. The surface roughness on last graph shown on the left side gives an example of the ideal surface. It is also seen that we do not want to have Rmr value to be 100%. If the Rmr value is higher than 90%, the sliding surface behaves like a mirror and do not leave any oil film on the surface. This basically makes the sealing element to be damaged in shorter period of time.

Figure 8
Surface roughness samples

SYSTEM TOLERANCES AND DESIGNS

System tolerances are the important factors on the life span of the sealing elements. Inappropriate dimensions, tolerances and decentered hydraulic cylinders make the sealing elements wear out in short period of time and the system do not give the required performance.

All the dimensions and tolerances are indicated on the product pages of our catalogue. Table 2 shows the general tolerances used in the hydraulic systems. The cylinder bore in hydraulic system is produced from ST 52 or better quality.

Sliding surfaces should have the mentioned operations (honed, grinded, etc) in order to obtain the required surface roughness values. Rods should be produced from steel (chrome plated, grinded and polished). Other cylinder parts should be from steel, steel casting, cast iron or special engineering plastics.

Below are some gland cap and piston designs in hydraulic cylinders depending on the sealing elements and applications;

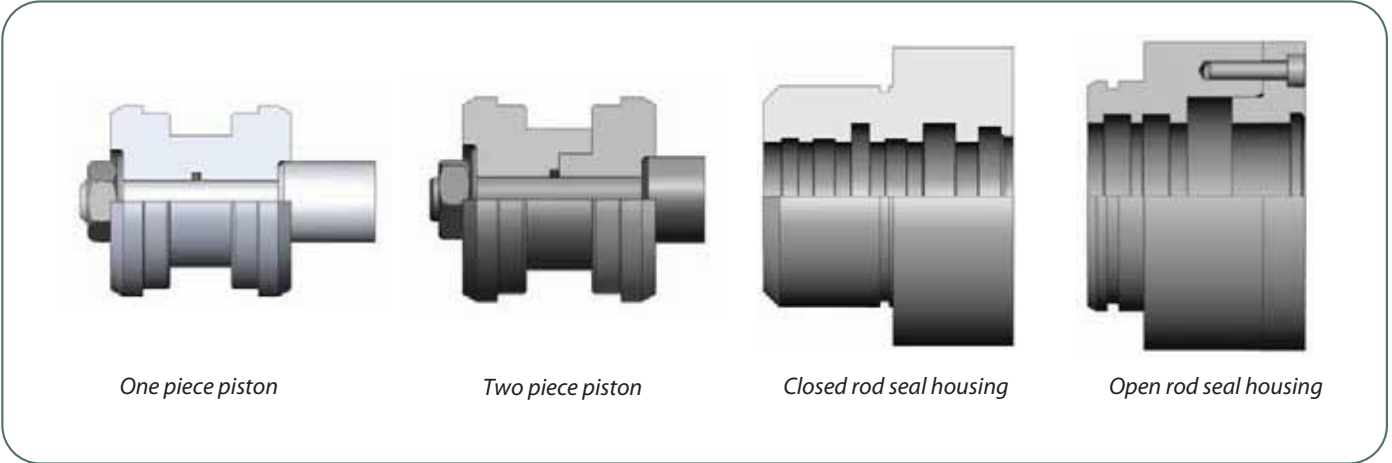

Sample gland cap and piston designs

TOLERANCES IN HYDRAULIC CYLINDERS

NOMINAL DIMENSION (mm)		HOLE TOLERANCES (µm)										ROD TOLERANCES (µm)					
		H8	H9	H10	H11	H12	e9	f7	f8	f9	h8	h9	h10	h11			
>	3	+14	+25	+40	+60	+100	-14	-6	-6	-6	0	0	0	0			
		-0	-0	-0	-0	-0	-39	-16	-20	-31	-14	-25	-40	-60			
3	6	+18	+30	+48	+75	+120	-20	-10	-10	-10	0	0	0	0			
		-0	-0	-0	-0	-0	-50	-22	-28	-40	-18	-30	-48	-75			
6	10	+22	+36	+58	+90	+150	-25	-13	-13	-13	0	0	0	0			
		-0	-0	-0	-0	-0	-61	-28	-35	-49	-22	-36	-58	-90			
10	18	+27	+43	+70	+110	+180	-32	-16	-16	-16	0	0	0	0			
		-0	-0	-0	-0	-0	-75	-34	-43	-59	-27	-43	-70	-110			
18	30	+33	+52	+84	+130	+210	-40	-20	-20	-20	0	0	0	0			
		-0	-0	-0	-0	-0	-92	-41	-53	-72	-33	-52	-84	-130			
30	50	+39	+62	+100	+160	+250	-50	-25	-25	-25	0	0	0	0			
		-0	-0	-0	-0	-0	-112	-50	-64	-87	-39	-62	-100	-160			
50	80	+46	+74	+120	+190	+300	-60	-30	-30	-30	0	0	0	0			
		-0	-0	-0	-0	-0	-134	-60	-76	-104	-46	-74	-120	-190			
80	120	+54	+87	+140	+220	+350	-72	-36	-36	-36	0	0	0	0			
		-0	-0	-0	-0	-0	-159	-71	-90	-123	-54	-87	-140	-220			
120	180	+63	+100	+160	+250	+400	-85	-43	-43	-43	0	0	0	0			
		-0	-0	-0	-0	-0	-185	-83	-106	-143	-63	-100	-160	-250			
180	250	+72	+115	+185	+290	+460	-100	-50	-50	-50	0	0	0	0			
		-0	-0	-0	-0	-0	-215	-96	-122	-165	-72	-115	-185	-290			
250	315	+81	+130	+210	+320	+520	-110	-56	-56	-56	0	0	0	0			
		-0	-0	-0	-0	-0	-240	-108	-137	-185	-81	-130	-210	-320			
315	400	+89	+140	+230	+360	+570	-125	-62	-62	-62	0	0	0	0			
		-0	-0	-0	-0	-0	-265	-119	-151	-202	-89	-140	-230	-360			
400	500	+97	+155	+250	+400	+630	-135	-68	-68	-68	0	0	0	0			
		-0	-0	-0	-0	-0	-290	-131	-165	-223	-97	-155	-250	-400			

PERMISSIBLE SEALING GAP

Elastomers used in sealing elements are visco elastic materials. Viscous characteristic is symbolized in Figure 9 with the force P applied on the plate in water, showing the final position. Elastic characteristic is symbolized in Figure 10 with the force P applied on the plate attached to a spring, the plate moves and when the force disappears, the spring moves back to its original position. The permissible sealing gap indicated as "S" in our catalogue should be checked carefully in order to prevent extrusion of the product during the application. In case of having values out of the indicated catalogue information, we recommend to use back-up rings as indicated in Figure 11.

One of the main problems during the application of the sealing element is the permissible sealing gap can not withstand the maximum operating pressure and due to this reason the product deforms and extrudes. We have indicated the permissible sealing gap values in the product pages of our catalogue for different operating pressures.

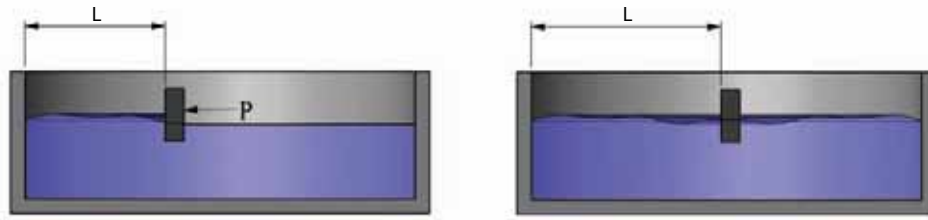

Figure 9
Viscos characteristic of Elastomers

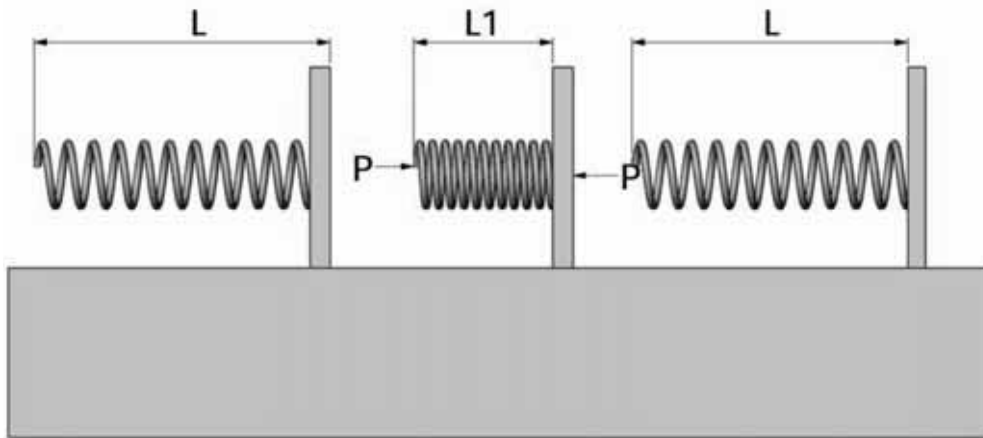

Figure 10
Elastic characteristic of Elastomers

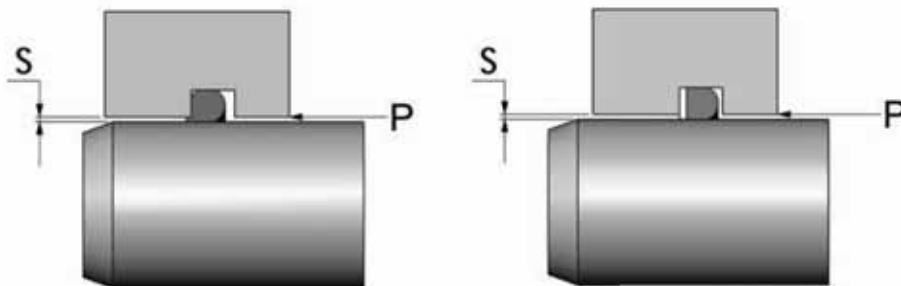

Figure 11
Permissible sealing gap

INSTALLATION

Before installation; we highly recommend to see section; General Installation Information of Technical Catalogue. Heating the seals before installation to +70°C hot oil will make the seal material more elastic and it will be easier to install the seal. It is very important not to create any condition to damage the material of the sealing element during this process.

Hydraulic sealing elements can be installed to the open and closed grooves by hand. We recommend special assembly tools for the installation of the sealing elements in especially closed grooves. These assembly tools will speed up the installation and prevent the damaging of the sealing element. Different assembly tool samples can be seen in Figure 12.

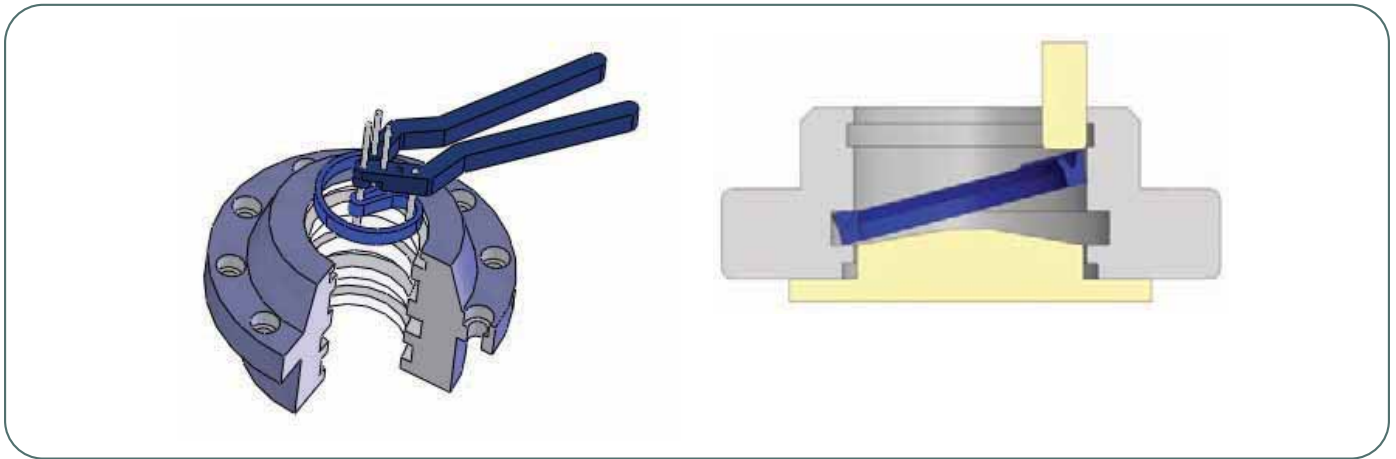

Figure 12
Sample assembly tools for closed rod seal housing

After the installation of the rod seals, in order not to have damage on the sealing elements while pushing the rod through the gland cap special assembly tool shown in Figure 13 should be used in order to protect the seals while the rod is inserted to the gland cap. All the assembly tools should not have any sharp edges and the surface roughness should be less than $R_t \leq 4\mu\text{m}$.

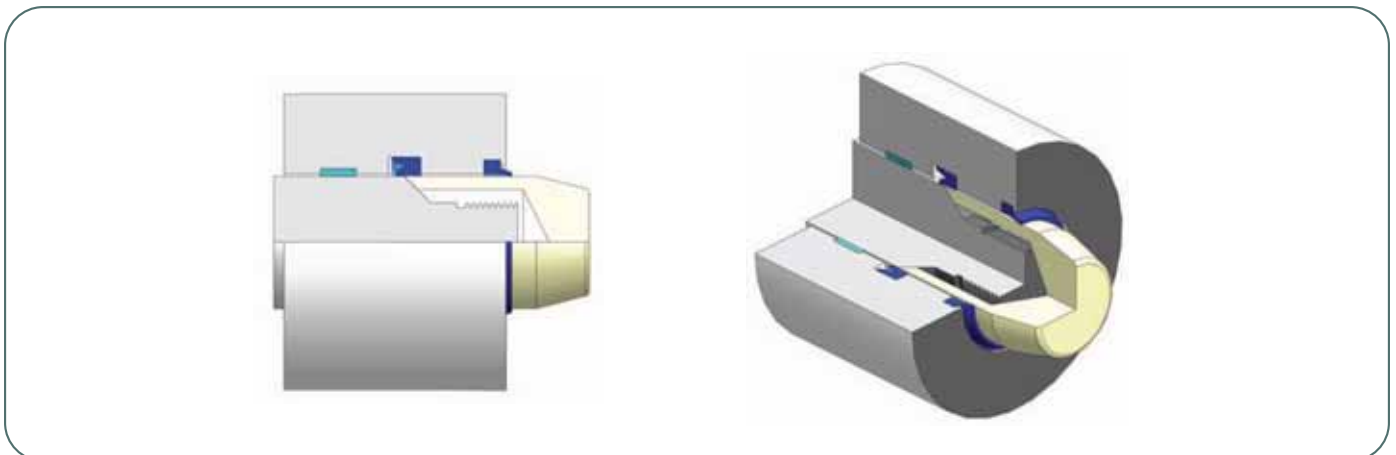

Figure 13
Assembly device after seal is installed

The assembly tool shown in Figure 14 should be used in order to protect the seals while the piston head is inserted to the cylinder bore.

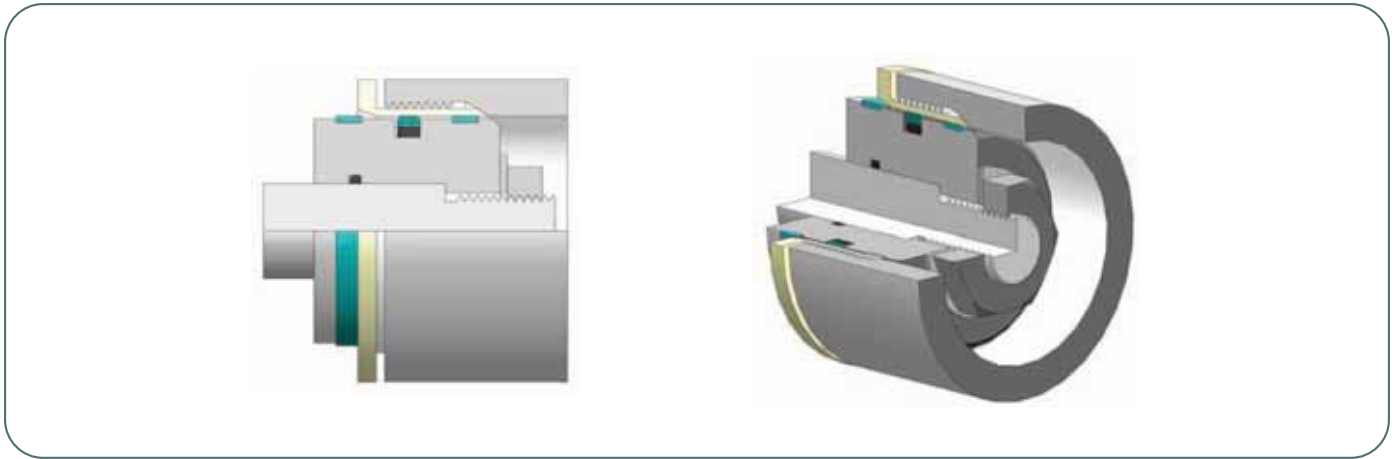

Figure 14
Sample assembly tools for pistons

Installation of the compact seals into the rod piston is shown in Figure 15. Rubber sealing element can be easily installed with the aid of simple installation tool. The other parts of the compact seal can be installed easily by hand. See the following illustrations.

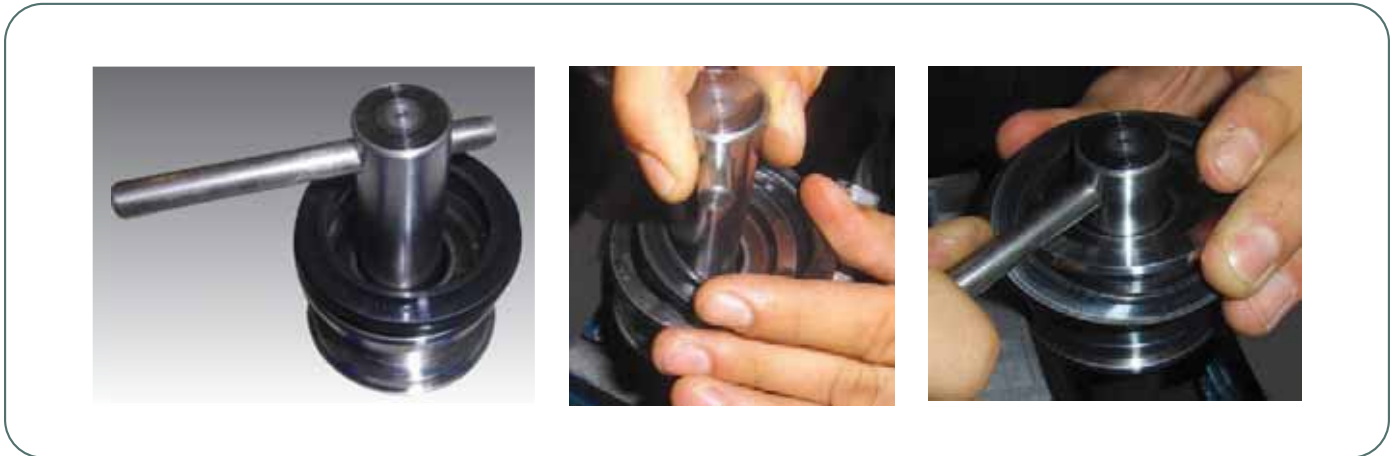

Figure 15
Installation of compact seals

PTFE ROD SEALING ELEMENT INSTALLATION

All the assembly tools should be produced from soft material such as POM, PA, etc not to have damage on the sealing elements during the installation process.

Sealing elements can be installed easily into open grooves. In order to prevent damage on the sealing during the installation we recommend having open groove design. In closed grooves, the energizer ring is firstly installed in the housing. PTFE sealing element is placed on the front of the expanding mandrel. The conical sleeve is centered with the gland cap (Figure 16). Then expanding mandrel is moved inside the conical sleeve in order to install the PTFE sealing into the respective housing.

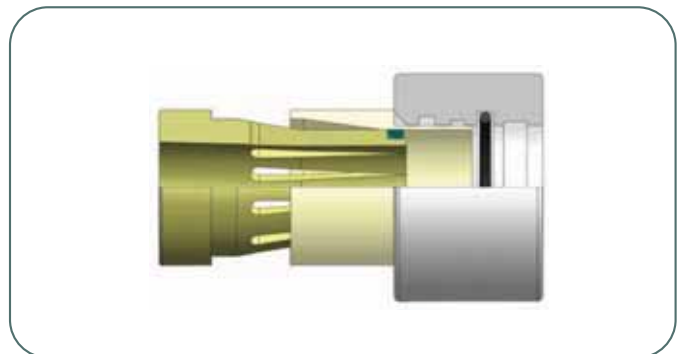

Figure 16
Assembly tool for PTFE rod sealing element

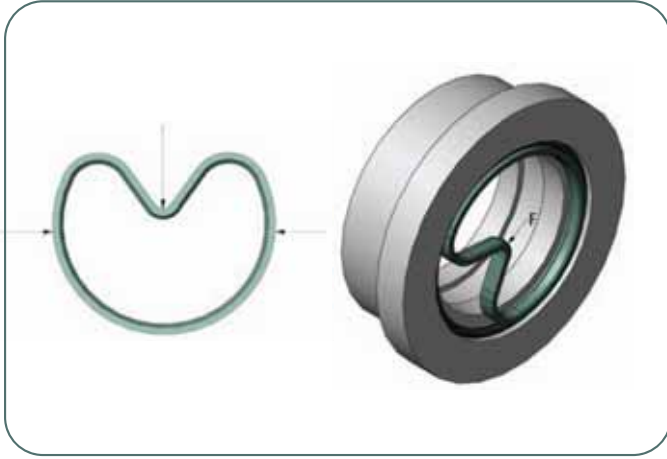

Figure 17
Installation of PTFE rod sealing element

PTFE sealing element pressed into a kidney shape without making sharp edges and placed into the groove (Figure 17).

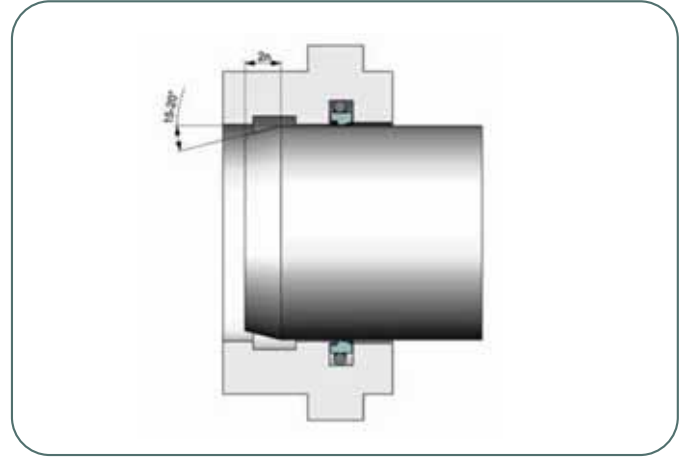

Figure 18
Calibrating mandrel

Calibrating mandrel as shown in Figure 18 is used for the PTFE sealing element to come to the original form.

In order to get the PTFE seal to its original shape a cylinder bore with twice the chamfer dimension should be used (See Figure 20).

PTFE PISTON SEALING ELEMENT INSTALLATION

All the assembly tools should be produced from soft material such as POM, PA, etc not to have damage on the sealing elements during the installation process.

Sealing elements are being installed into two piece piston easily and placed into housing by the help of the cylinder bore. Prior to installation chamfer on the bore should be checked.

PTFE seal can be heated up to 80 °C in hot system oil or air for an easy assembly before installing into the closed groove. Energizer ring is inserted into the groove without twisting. PTFE sealing is placed into the groove by help of the assembly tools shown in Figure 19.

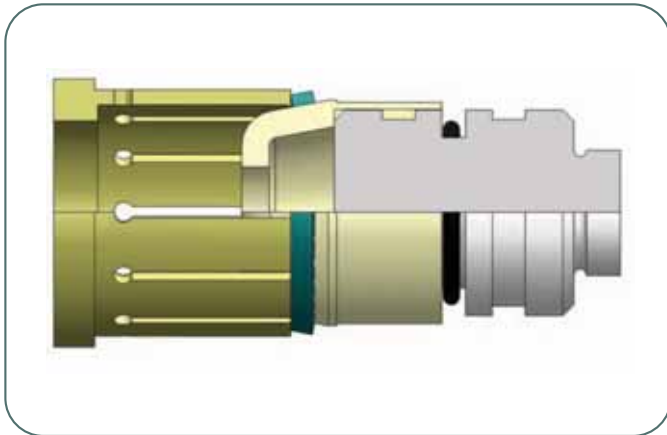

Figure 19
Assembly tool for piston

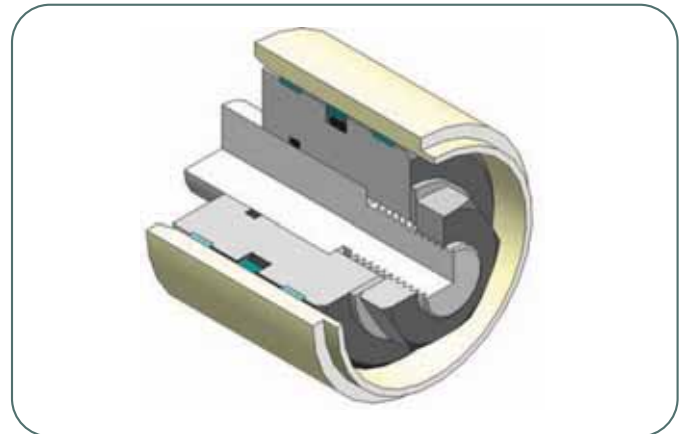

Figure 20
Calibrating bore

In order to prevent damage of the sealing element, the piston should be installed into the cylinder bore with the assembly tool shown in Figure 21.

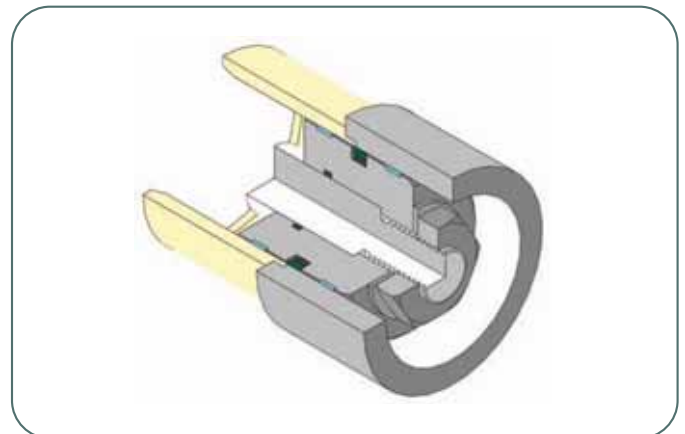
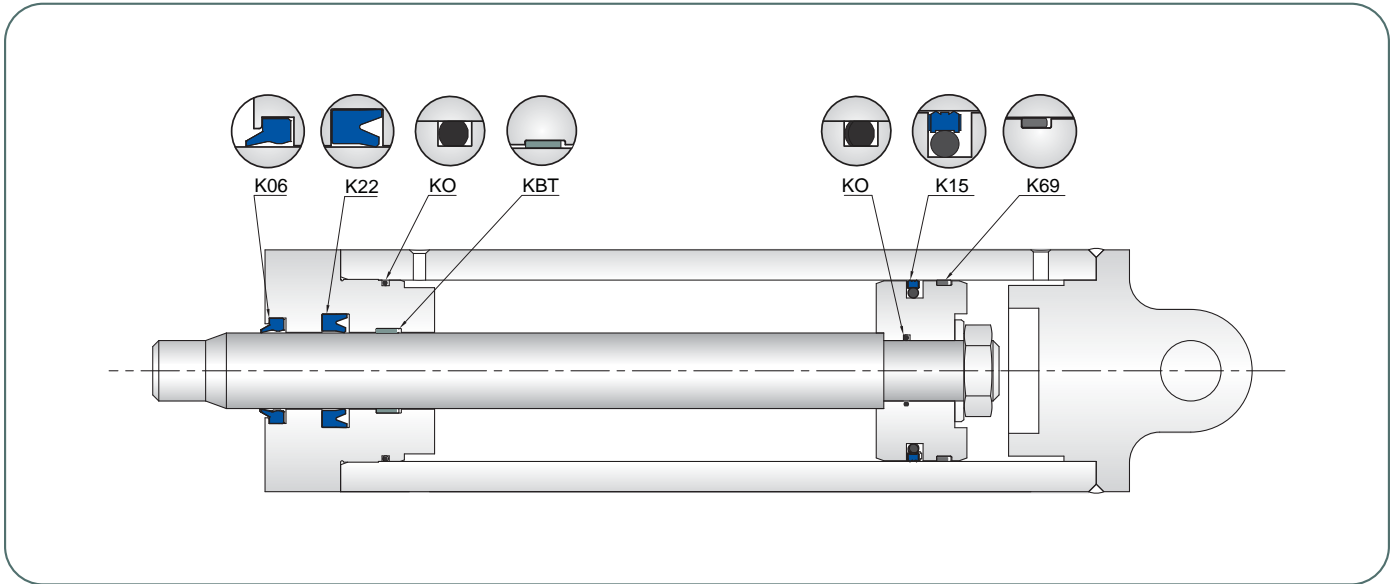
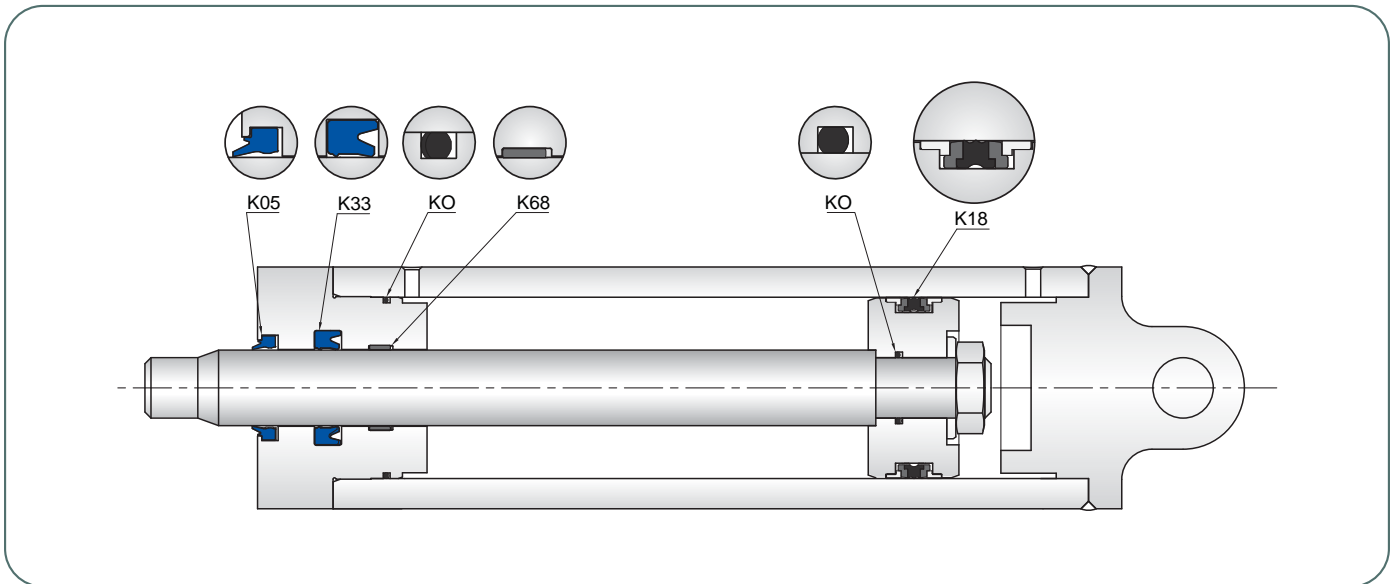

Figure 21
Assembly tool for piston

SAMPLE DESIGNS



Light duty sample design-1



Light duty sample design-2

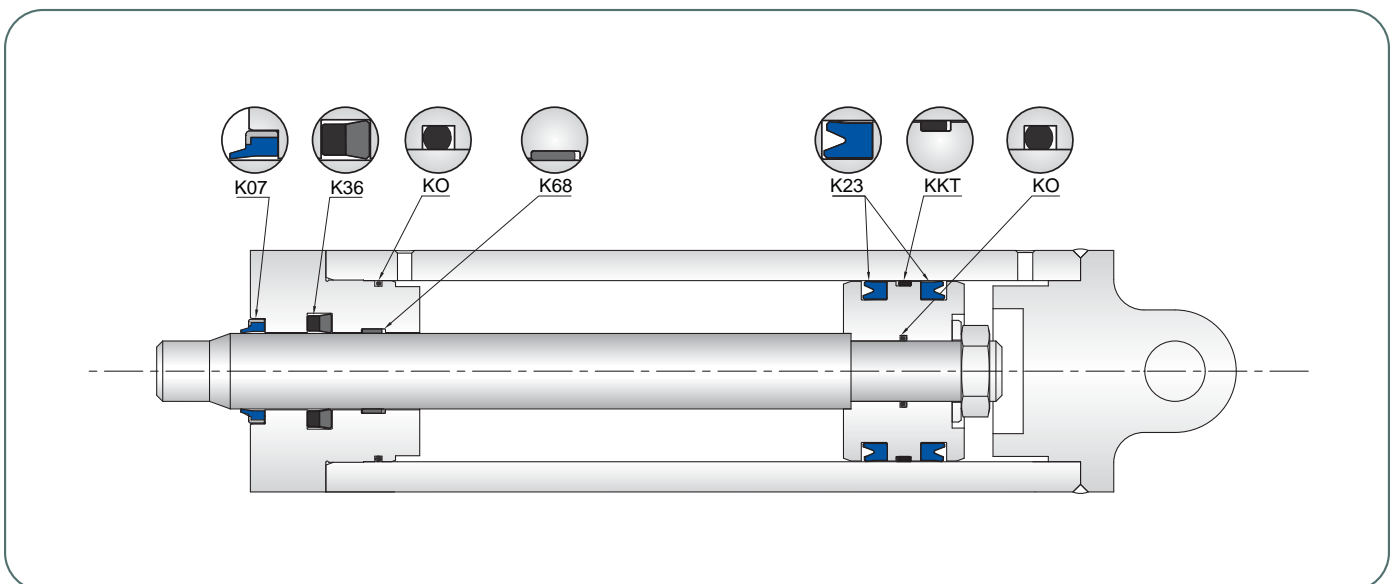

Light duty sample design-3

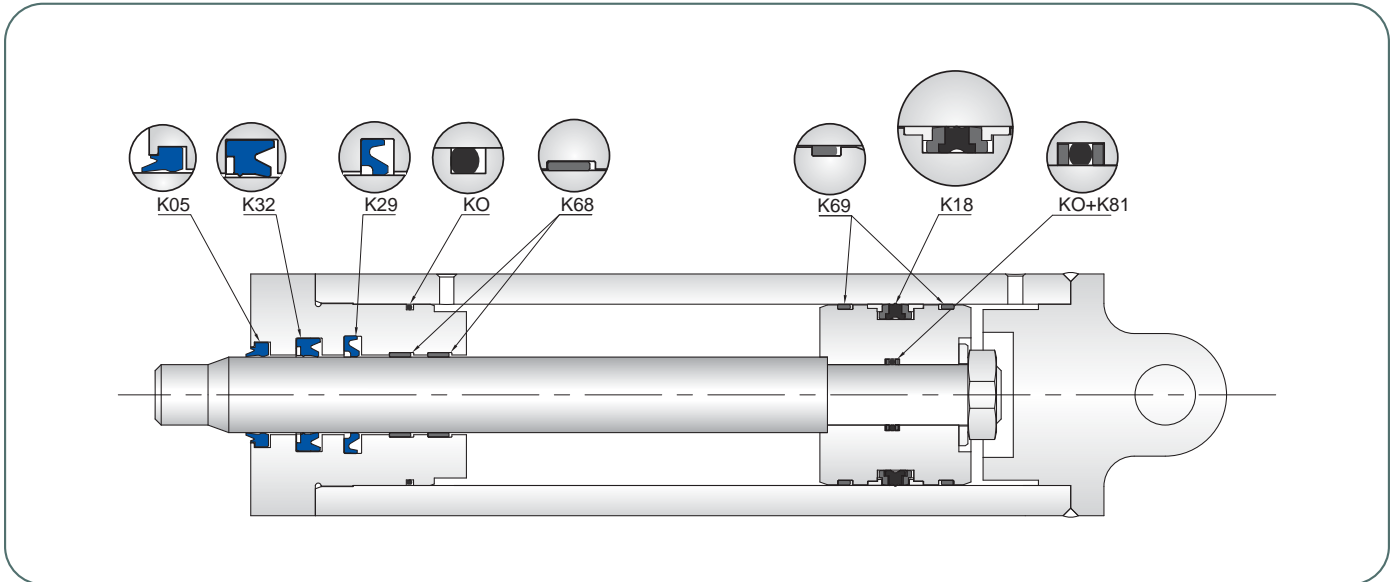

Medium duty sample design-4

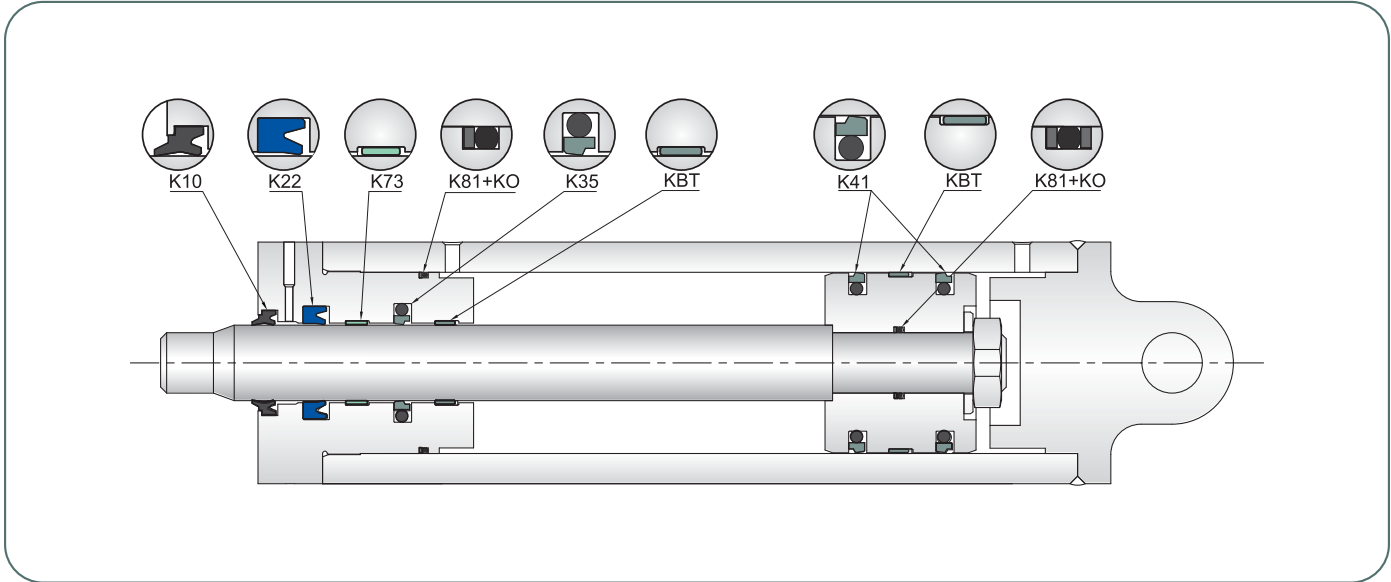

Medium duty sample design-5

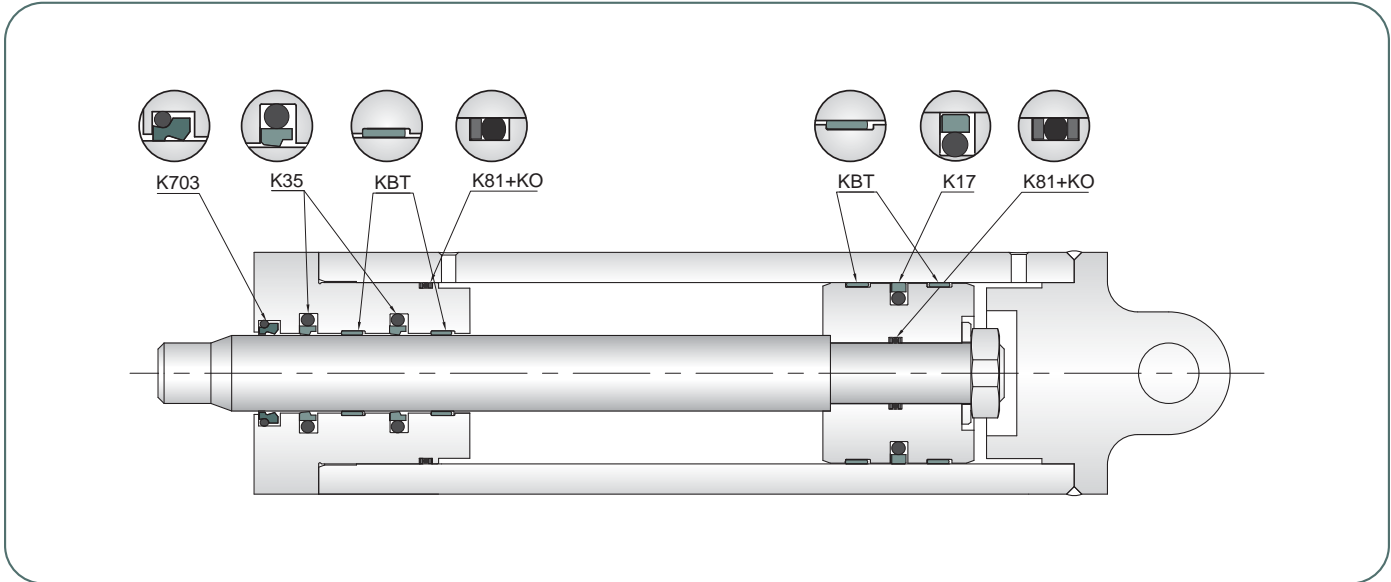

Medium duty sample design-6

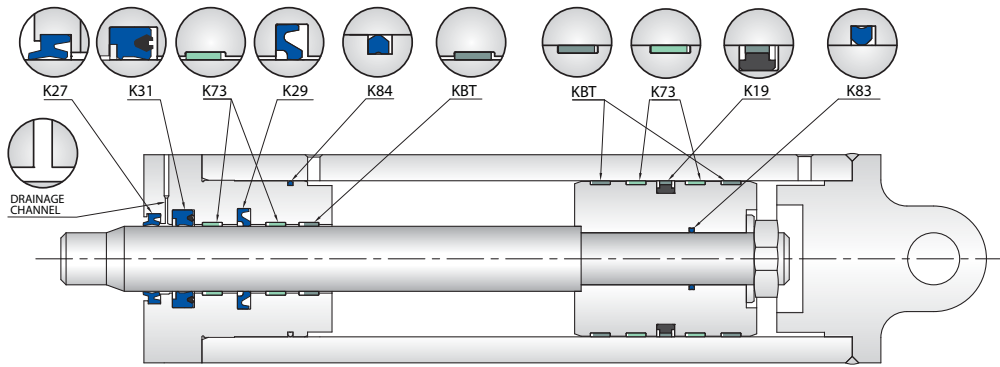

Heavy duty sample design-7

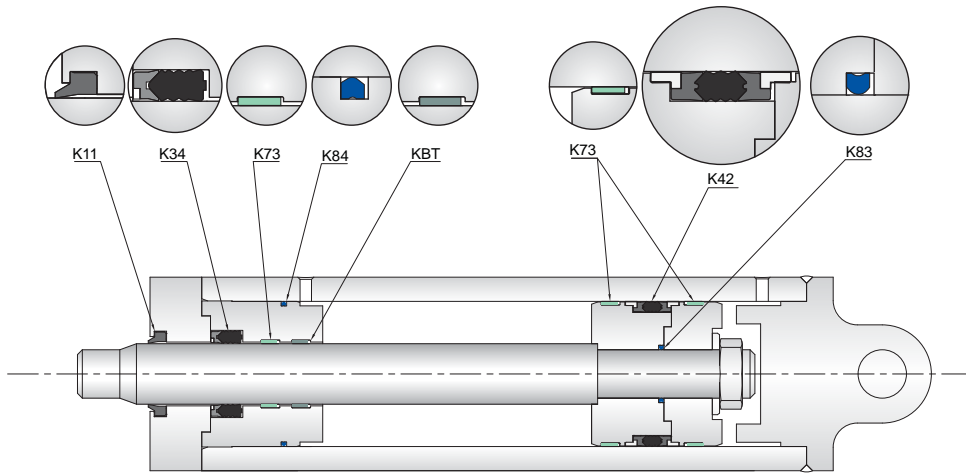

Heavy duty sample design-8

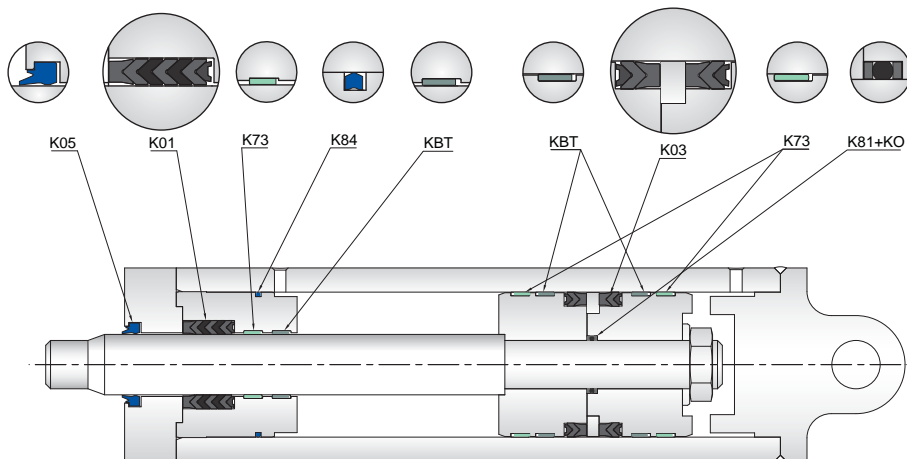

Heavy duty sample design-9



HYDRAULIC PISTON - ROD SEALING ELEMENTS



Lined writing area consisting of 25 horizontal light gray lines.

KASTAS CODE	PRODUCT NAME	DRAWING	APPLICATION	MATERIAL	CODE	PRESSURE (max) bar	TEMPERATURE (max) °C	SLIDING SPEED (max) - m/sec	PAGE
K21	Piston Rod Seal		Piston Rod	NBR PU	NB9001 PU9201	150 400	-30/+105 -30/+100	0.5 0.5	34
K36	Piston Rod Seal		Piston Rod	NBR FABRIC NBR	NB8001 NB8008	250	-30/+105	0.5	48
K95	Piston Rod Seal		Piston Rod	NBR	NB9001	150	-30/+105	0.5	52
KX	X-Ring		Rod Piston	NBR	NB7001	50	-30/+105	0.5	56



K21 is a single acting piston - rod seal and designed to have symmetrical lips in order to be used both for rod and piston applications.

PRODUCT ADVANTAGES

- Superior static and dynamic sealing effect
- Wide range of dimensions
- Easy assembly into closed grooves
- Simple groove design
- Economical sealing solution

APPLICATION

Construction machinery, fork-lift trucks, injection moulding machines, agricultural machinery, loading platforms and standard cylinders.

MATERIAL		CODE
NBR	90 SHORE A	NB9001
PU	92 SHORE A	PU9201

OPERATING CONDITIONS			
NBR			
MEDIA	Mineral oils (DIN 51524)	HFA and HFB	HFC
TEMPERATURE	-30°C +105°C	+5°C +60°C	-30°C +60°C
PRESSURE	≤150 Bar	≤150 Bar	≤150 Bar
SPEED	≤0.5 m/sec	≤0.5 m/sec	≤0.5 m/sec
PU			
MEDIA	Mineral oils (DIN 51524)	HFA and HFB	HFC
TEMPERATURE	-30°C +100°C	+5°C +50°C	-30°C +40°C
PRESSURE	≤400 Bar	≤400 Bar	≤400 Bar
SPEED	≤0.5 m/sec	≤0.5 m/sec	≤0.5 m/sec

Note: The above data are maximum values and cannot be used at the same time.

SURFACE ROUGHNESS	Ra	Rmax	
Sliding Surface	$\varnothing D - \varnothing d$	≤0.4 μm	≤3.2 μm
Groove Base	$\varnothing D_b - \varnothing d_p$	≤1.6 μm	≤10 μm
Groove Flanks	B	≤3.2 μm	≤16 μm

Note: It is recommended to have 50% to 90% of the working surface material contact area value.

INSTALLATION

Easily assembled into closed grooves according to the minimum diameter values that are given in the below table. Open grooves or special assembly tools should be used for the values that are outside this table. It is very important that the assembly tools must be of soft material and have no sharp edges. Before installation the seal must be oiled with system oil.

MINIMUM DIAMETER VALUES FOR CLOSED TYPE OF GROOVES

(D-d)/2 (mm)	4	5	6	7.7	10	12.5	15
dmin (mm)	25	30	40	50	80	100	105

NOTES

For special applications that require high temperatures, K21 can be produced in FKM. The permissible sealing gap values of K21 piston - rod seal is given in the below table.

PERMISSIBLE SEALING GAP			
NBR		Smax (mm)	
t=(D-d)/2	50 Bar	100 Bar	150 Bar
t≤5	0.40	0.20	0.10
t>5	0.45	0.25	0.15
PU		Smax (mm)	
t=(D-d)/2	150 Bar	250 Bar	400 Bar
t≤5	0.30	0.20	0.15
t>5	0.35	0.25	0.20

Note: The largest sealing gap value occurring on the non-pressurized side of the seal does have a vital importance for the function of the seal and in this respect it is quite important to use the S value lower than the above indicated numbers.

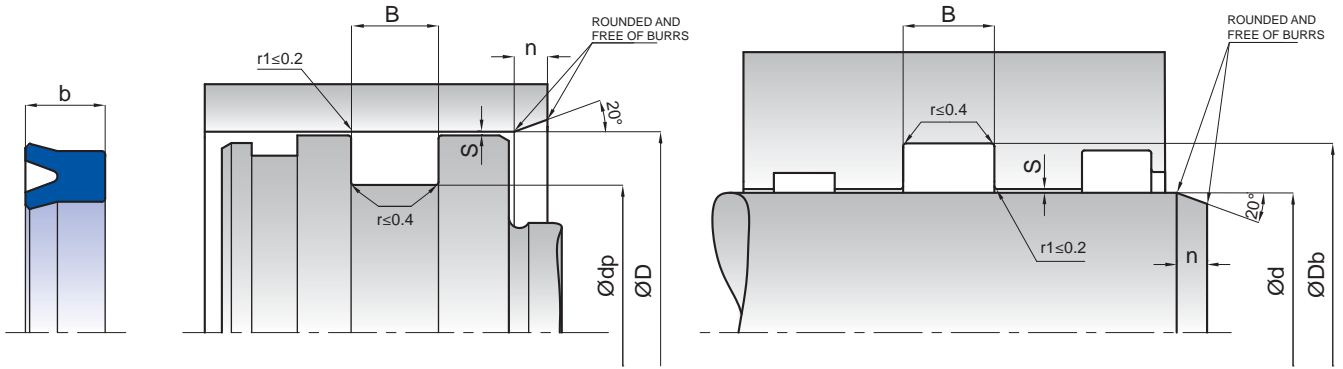

KASTAŞ NO	NBR	PU	d (f7)/dp (h11)	Db (H11)/D (H11)	b	B (-0/+0.2)	n
K21-003/2	NBR	PU	3	8	3.5	4	2.5
K21-003/4	NBR	PU	3	10	6	7	3.5
K21-003/5	NBR		3	8	4.5	5	2.5
K21-004	NBR		4	10	5	6	3
K21-004/1	NBR	PU	4	12	5.5	6.5	4
K21-004/2	NBR		4	12	4	4.5	4
K21-004/3	NBR	PU	4	10	4	4.5	3
K21-004/4	NBR		4	7.5	3	3.5	2
K21-004/5	NBR		4	10	4.5	5	3
K21-004/6	NBR	PU	4	10	6	7	3
K21-005	NBR	PU	5	11	7	8	3
K21-005/2	NBR	PU	5	11	5	6	3
K21-005/3	NBR	PU	5	10	4	4.5	2.5
K21-005/4	NBR	PU	5	10	5	6	2.5
K21-005/5	NBR		5	9	2.4	2.9	2
K21-005/6	NBR	PU	5	12	5	6	3.5
K21-005/7	NBR		5	14	4.5	5	4
K21-005/8	NBR		5	12	4	4.5	3.5
K21-006	NBR		6	9	2	2.5	2
K21-006/1	NBR	PU	6	12	6	7	3
K21-006/10	NBR		6	14	6	7	4
K21-006/11	NBR	PU	6	20	8	9	5.5
K21-006/12	NBR	PU	6	14	4	4.5	4
K21-006/13	NBR	PU	6	16	5	6	4.5
K21-006/14	NBR		6	12	5	6	3
K21-006/2	NBR	PU	6	12	7	8	3
K21-006/3	NBR	PU	6	10	3	3.5	2
K21-006/4	NBR	PU	6	15	5	6	4
K21-006/5	NBR	PU	6	16	6	7	4.5
K21-006/6	NBR	PU	6	12	4	4.5	3
K21-006/7	NBR	PU	6.35	12.7	6.35	7.35	3
K21-006/8	NBR	PU	6	18	8	9	5
K21-006/9	NBR	PU	6	13	5.5	6.5	3.5
K21-007	NBR	PU	7	15	5	6	4
K21-007/1	NBR	PU	7	14	7	8	3.5
K21-007/2	NBR		7	12.5	3.5	4	3
K21-007/3	NBR	PU	7	15	7	8	4
K21-007/4	NBR	PU	7	13	3.5	4	3
K21-007/5	NBR		7	12	4	4.5	2.5
K21-007/6	NBR		7	11	3.5	4	2
K21-008	NBR	PU	8	18	8	9	4.5
K21-008/1	NBR	PU	8	14	6	7	3
K21-008/10	NBR		8	15	6	7	3.5
K21-008/11	NBR	PU	8	20	8	9	5
K21-008/12	NBR		8	17	6	7	4
K21-008/13	NBR		8	15	5.2	6.2	3.5
K21-008/14	NBR		8	15	2.5	3	3.5
K21-008/15		PU	8	15	5	6	3.5
K21-008/16		PU	8	12	4	4.5	2

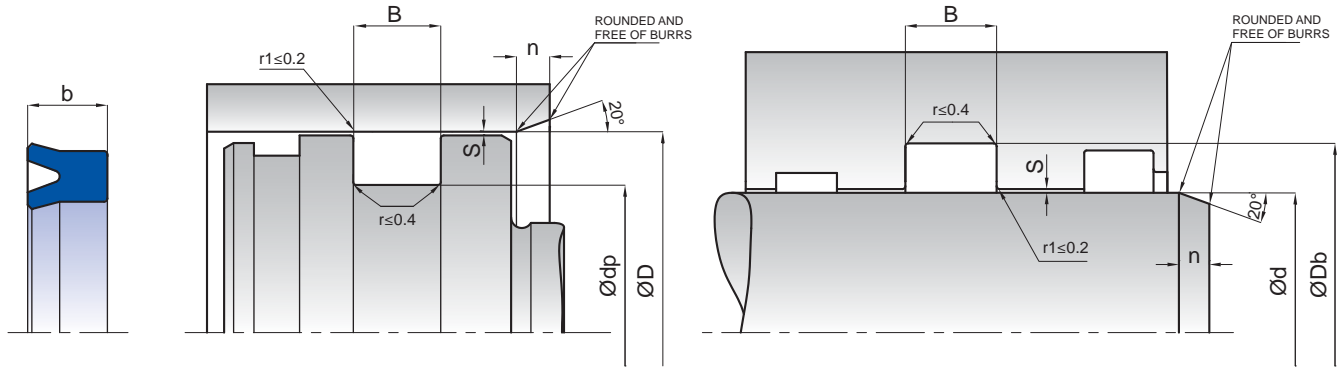

KASTAŞ NO	NBR	PU	d (f7)/dp (h11)	Db (H11)/D (H11)	b	B (-0/+0.2)	n
K21-008/2	NBR	PU	8	16	6	7	4
K21-008/3	NBR	PU	8	16	8	9	4
K21-008/5	NBR	PU	8	14	4	4.5	3
K21-008/7	NBR	PU	8	15	8	9	3.5
K21-008/8	NBR	PU	8	12	5	6	2
K21-008/9	NBR	PU	8	13	7	8	2.5
K21-009	NBR	PU	9	17	6	7	4
K21-009/1	NBR	PU	9	19	6	7	4.5
K21-009/2	NBR	PU	9	16	4	4.5	3.5
K21-009/3	NBR	PU	9	16	7	8	3.5
K21-009/4	NBR	PU	9	17	5.5	6.5	4
K21-010	NBR	PU	10	20	8	9	4.5
K21-010/10	NBR	PU	10	15	4	4.5	2.5
K21-010/11	NBR	PU	10	16	6	7	3
K21-010/12	NBR	PU	10	16	5	6	3
K21-010/13	NBR	PU	10	20	7	8	4.5
K21-010/14	NBR	PU	10	22	9	10	5
K21-010/16	NBR	PU	10	14	3.5	4	2
K21-010/17	NBR	PU	10	20	6.5	7.5	4.5
K21-010/18	NBR	PU	10	26	8	9	6
K21-010/19	NBR	PU	10	22	6	7	5
K21-010/2	NBR	PU	10	18	8	9	4
K21-010/20	NBR	PU	10	18	4	4.5	4
K21-010/3	NBR	PU	10	28	10	11	6
K21-010/4	NBR	PU	10	18	6	7	4
K21-010/5	NBR	PU	10	22	8	9	5
K21-010/6	NBR	PU	10	16	4	4.5	3
K21-010/7	NBR	PU	10	25	8	9	5.5
K21-010/8	NBR	PU	10	25	10	11	5.5
K21-010/9	NBR	PU	10	26	9.5	10.5	6
K21-012	NBR	PU	12	22	8	9	4.5
K21-012/1	NBR	PU	12	20	8	9	4
K21-012/10	NBR	PU	12	18	3	3.5	3
K21-012/11	NBR	PU	12	20	5	6	4
K21-012/12	NBR	PU	12	25	8	9	5
K21-012/14	NBR	PU	12	24	6	7	5
K21-012/15	NBR	PU	12	28	10	11	6
K21-012/16	NBR	PU	12	16	3	3.5	2
K21-012/17	NBR	PU	12	22	7	8	4.5
K21-012/18	NBR	PU	12.7	25.4	6.35	7.35	5
K21-012/2	NBR	PU	12	22	6	7	4.5
K21-012/20	NBR	PU	12	17	3	3.5	2.5
K21-012/21	NBR	PU	12	20	6.8	7.8	4
K21-012/23	NBR	PU	12	26	10	8	5
K21-012/24	NBR	PU	12	32	10	11	6
K21-012/25	NBR	PU	12	19.5	7	8	4
K21-012/3	NBR	PU	12	24	7	8	5
K21-012/4	NBR	PU	12	24	10	11	5
K21-012/5	NBR	PU	12	18	6	7	3

KASTAŞ NO	NBR	PU	d (f7)/dp (h11)	Db (H11)/D (H11)	b	B (-0/+0.2)	n
K21-012/6	NBR		12	22	5	6	4.5
K21-012/7	NBR	PU	12	18	4	4.5	3
K21-012/8	NBR	PU	12	18	5	6	3
K21-012/9	NBR	PU	12	20	5.5	6.5	4
K21-013/1	NBR	PU	13	25	8	9	5
K21-014	NBR	PU	14	24	8	9	4.5
K21-014/1	NBR	PU	14	22	5	6	4
K21-014/10	NBR	PU	14	32	8	9	6
K21-014/11	NBR	PU	14	22	6	7	4
K21-014/12	NBR	PU	14	28	7	8	5.5
K21-014/13	NBR	PU	14	24	5	6	4.5
K21-014/2	NBR	PU	14	22	12	13	4
K21-014/3	NBR	PU	14	24	6	7	4.5
K21-014/4	NBR	PU	14	28	10	11	5.5
K21-014/5	NBR		14	22	8	9	4
K21-014/6	NBR	PU	14	20	5	6	3
K21-014/7	NBR	PU	14	20	6	7	3
K21-014/8	NBR	PU	14	20	4	4.5	3
K21-014/9	NBR	PU	14	22	4	4.5	4
K21-015	NBR	PU	15	25	8	9	4.5
K21-015/10	NBR	PU	15	21	3.5	4	3
K21-015/11	NBR		15	22	5	6	3.5
K21-015/12	NBR	PU	15	28	10	11	5
K21-015/13	NBR	PU	15	30	10	11	5.5
K21-015/14	NBR		15.87	25.4	4.76	5.26	4.5
K21-015/15	NBR	PU	15	30	8	9	5.5
K21-015/16	NBR		15	25	6	7	4.5
K21-015/17	NBR	PU	15	22	5.5	6.5	3.5
K21-015/18	NBR	PU	15	22	8	9	3.5
K21-015/2	NBR	PU	15	28	8	9	5
K21-015/4	NBR		15	25	5	6	4.5
K21-015/5	NBR		15	22	4	4.5	3.5
K21-015/6	NBR	PU	15	30	6	7	5.5
K21-015/7	NBR	PU	15	20	3	3.5	2.5
K21-015/8	NBR	PU	15	25	10	11	4.5
K21-016	NBR	PU	16	26	8	9	4.5
K21-016/1	NBR	PU	16	22	5	6	3
K21-016/10	NBR	PU	16	25	5	6	4
K21-016/13	NBR	PU	16	24	6	7	4
K21-016/14	NBR	PU	16	22	10	11	3
K21-016/16	NBR	PU	16	28	6	7	5
K21-016/2	NBR	PU	16	26	6	7	4.5
K21-016/4	NBR		16	32	10	11	6
K21-016/5	NBR		16	24	4	4.5	4
K21-016/6	NBR	PU	16	22	3	3.5	3
K21-016/7	NBR	PU	16	29	6	7	5
K21-016/8	NBR	PU	16	26	5	6	4.5
K21-016/9	NBR	PU	16	22	4	4.5	3
K21-017/1	NBR	PU	17	32	10	11	5.5
K21-017/2	NBR	PU	17	25	4	4.5	4
K21-018	NBR	PU	18	28	8	9	4.5
K21-018/1	NBR	PU	18	30	6	7	5
K21-018/10	NBR	PU	18	28	6	7	4.5
K21-018/11	NBR	PU	18	24	8	9	3
K21-018/12	NBR	PU	18	26	4	4.5	4
K21-018/2	NBR	PU	18	30	7.5	8.5	5
K21-018/3	NBR	PU	18	30	8.5	9.5	5
K21-018/4	NBR	PU	18	30	10	11	5
K21-018/5	NBR		18	25	5.5	6.5	3.5
K21-018/6	NBR	PU	18	32	7	8	5.5
K21-018/7	NBR	PU	18	25	5	6	3.5
K21-018/8	NBR		18	24	4	4.5	3
K21-018/9	NBR	PU	18	26	5	6	4
K21-019/3	NBR	PU	19	25	6	7	3
K21-019/4	NBR	PU	19.5	23.91	4.81	5.81	2

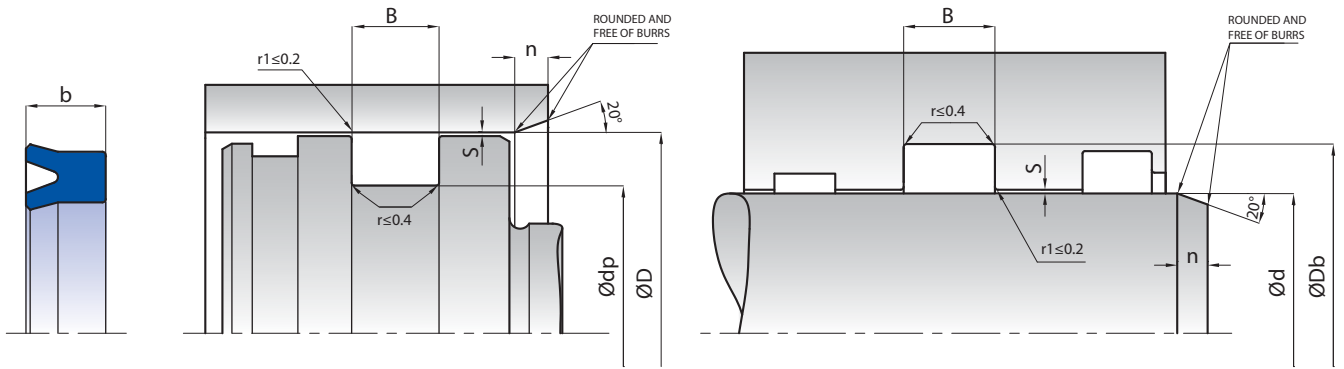

KASTAŞ NO	NBR	PU	d (f7)/dp (h11)	Db (H11)/D (H11)	b	B (-0/+0.2)	n
K21-019/6	NBR	PU	19	27	4	4.5	4
K21-020	NBR	PU	20	30	8	9	4.5
K21-020/1	NBR	PU	20	28	5	6	4
K21-020/10	NBR	PU	20	25	3.5	4	2.5
K21-020/11	NBR	PU	20	30	4	4.5	4.5
K21-020/12	NBR		20	26	6	7	3
K21-020/14	NBR	PU	20	27	6	7	3.5
K21-020/15	NBR	PU	20	36	10	11	6
K21-020/16	NBR	PU	20	40	12	13	6
K21-020/17	NBR	PU	20	32	7.5	8.5	5
K21-020/18	NBR	PU	20	32	11	12	5
K21-020/19	NBR	PU	20	35	12	13	5.5
K21-020/2	NBR	PU	20	30	6	7	4.5
K21-020/21	NBR		20	28	8	9	4
K21-020/22	NBR	PU	20	32	6	7	5
K21-020/23	NBR	PU	20	28	6	7	4
K21-020/24	NBR		20	25	2.5	3	2.5
K21-020/25	NBR	PU	20	30	5	6	4.5
K21-020/26		PU	20	27	5	6	3.5
K21-020/3	NBR	PU	20	30	10	11	4.5
K21-020/4	NBR	PU	20	35	10	11	5.5
K21-020/5	NBR	PU	20	40	10	11	6
K21-020/6	NBR	PU	20	32	5	6	5
K21-020/7	NBR	PU	20	36	8	9	6
K21-020/8	NBR	PU	20	28	4	4.5	4
K21-020/9	NBR	PU	20	25	3	3.5	2.5
K21-022	NBR	PU	22	32	8	9	4.5
K21-022/1	NBR	PU	22	32	7	8	4.5
K21-022/11	NBR	PU	22	30	5	6	4
K21-022/12	NBR	PU	22	38	10	11	6
K21-022/13		PU	22	32	10	11	4.5
K21-022/14	NBR	PU	22	32	5	6	4.5
K21-022/15	NBR	PU	22	30	10	11	4
K21-022/17	NBR	PU	22	46	12	13	7
K21-022/18	NBR	PU	22.4	30	5	6	4
K21-022/4	NBR	PU	22	34	6	7	5
K21-022/5	NBR	PU	22	30	6	7	4
K21-022/6	NBR	PU	22	42	10	11	6
K21-022/7	NBR	PU	22	34	10	11	5
K21-022/8	NBR	PU	22	32	6	7	4.5
K21-022/9	NBR	PU	22	40	10	11	6
K21-024	NBR	PU	24	34	5	6	4.5
K21-024/1	NBR	PU	24	32	4	4.5	4
K21-024/2	NBR	PU	24	40	8	9	6
K21-025	NBR	PU	25	40	10	11	5.5
K21-025/11	NBR	PU	25	33	4	4.5	4
K21-025/12	NBR	PU	25	38	7	8	5
K21-025/13	NBR		25.5	31	4.5	5	3
K21-025/14	NBR	PU	25	38	10	11	5

KASTAŞ NO	NBR	PU	d (f7)/dp (h11)	Db (H11)/D (H11)	b	B (-0/+0.2)	n
K21-025/15	NBR	PU	25	50	12	13	7
K21-025/16	NBR	PU	25	32	4	4.5	3.5
K21-025/17	NBR	PU	25	33	7	8	4
K21-025/18	NBR	PU	25	40	11	12	5.5
K21-025/19	NBR	PU	25	35	6	7	4.5
K21-025/2	NBR	PU	25	33	5	6	4
K21-025/20	NBR		25	40	7.5	8.5	5.5
K21-025/21	NBR		25	47	7	8	7
K21-025/22	NBR		25	32	5	6	3.5
K21-025/23	NBR	PU	25	35	10	11	4.5
K21-025/26	NBR	PU	25	36	6.9	7.9	5
K21-025/27	NBR	PU	25	38	9.5	10.5	5
K21-025/3	NBR	PU	25	35	5	6	4.5
K21-025/4	NBR	PU	25	35	7	8	4.5
K21-025/5	NBR	PU	25	35	8	9	4.5
K21-025/6	NBR	PU	25	37	7	8	5
K21-025/7	NBR	PU	25	38	9	10	5
K21-025/8	NBR	PU	25	45	10	11	6
K21-025/9	NBR	PU	25	32	7	8	3.5
K21-026/1	NBR	PU	26	42	8	9	6
K21-026/2	NBR	PU	26	35	8	9	4
K21-027	NBR	PU	27	35	4	4.5	4
K21-027/1	NBR	PU	27	38	6	7	5
K21-027/2	NBR		27	36	6	7	4
K21-028	NBR	PU	28	43	10	11	5.5
K21-028/1	NBR	PU	28	40	10	11	5
K21-028/10	NBR	PU	28	38	5	6	4.5
K21-028/11	NBR	PU	28	32.8	3	3.5	2.5
K21-028/12	NBR	PU	28	48	8.5	9.5	6
K21-028/13	NBR	PU	28	36	4	4.5	4
K21-028/14	NBR	PU	28	40	6	7	5
K21-028/2	NBR	PU	28	48	10	11	6
K21-028/3	NBR	PU	28	48	12	13	6
K21-028/4	NBR	PU	28	35	6	7	3.5
K21-028/5	NBR	PU	28	36	6	7	4
K21-028/6	NBR	PU	28	36	5	6	4
K21-028/7	NBR	PU	28	35.5	5	6	4
K21-028/8	NBR	PU	28	38	10	11	4.5
K21-028/9	NBR	PU	28	44	8	9	6
K21-030	NBR	PU	30	45	10	11	5.5
K21-030/1	NBR	PU	30	40	10	11	4.5
K21-030/10	NBR	PU	30	37	8	9	3.5
K21-030/11	NBR	PU	30	38	10	11	4
K21-030/12	NBR		30	47	10	11	6
K21-030/14	NBR		30	38	3	4	4
K21-030/15	NBR	PU	30	40	8	9	4.5
K21-030/16	NBR		30	36	3	4	3
K21-030/17	NBR	PU	30.16	38.1	3.97	4.97	4
K21-030/18	NBR	PU	30	37	6	7	3.5
K21-030/2	NBR	PU	30	42	10	11	5
K21-030/3	NBR	PU	30	50	10	11	6
K21-030/4	NBR	PU	30	50	12	13	6
K21-030/5	NBR		30	40	5	6	4.5
K21-030/6	NBR	PU	30	40	7	8	4.5
K21-030/7	NBR	PU	30	38	4	4.5	4
K21-030/8	NBR	PU	30	38	5.5	6.5	4
K21-030/9	NBR	PU	30	40	6	7	4.5
K21-031/2	NBR	PU	31.5	41.5	6	7	4.5
K21-032	NBR	PU	32	47	10	11	5.5
K21-032/1	NBR	PU	32	40	8	9	4
K21-032/10	NBR	PU	32	52	10	11	6
K21-032/11	NBR	PU	32	44	6	7	5
K21-032/12	NBR	PU	32	45	8	9	5
K21-032/13	NBR	PU	32	48	10	11	6

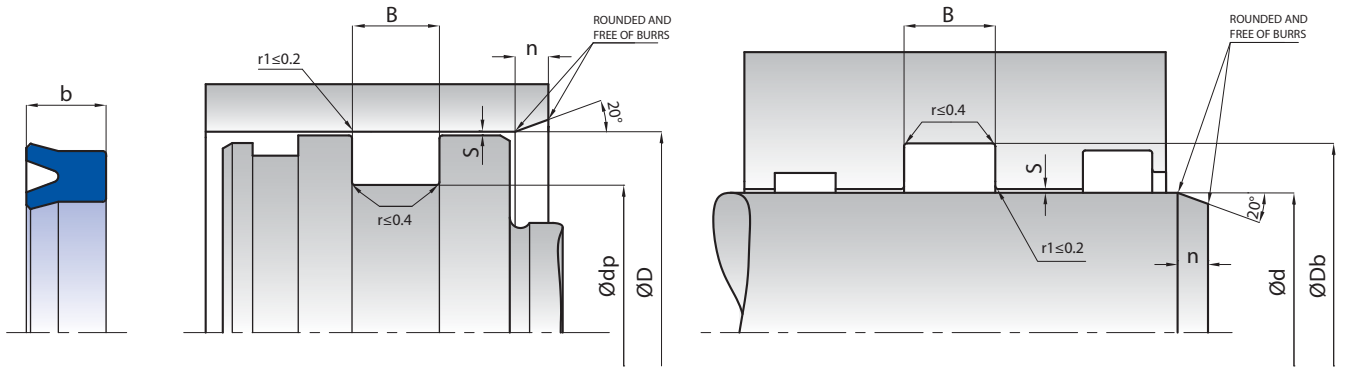

KASTAŞ NO	NBR	PU	d (f7)/dp (h11)	Db (H11)/D (H11)	b	B (-0/+0.2)	n
K21-032/3	NBR	PU	32	42	6	7	4.5
K21-032/4	NBR	PU	32	45	10	11	5
K21-032/5	NBR	PU	32	50	12	13	6
K21-032/6	NBR	PU	32	40	4	4.5	4
K21-032/7	NBR	PU	32	40	5	6	4
K21-032/8	NBR	PU	32	44	6.35	7.35	5
K21-032/9	NBR	PU	32	40	5.7	6.7	4
K21-033	NBR	PU	33	43	6	7	4.5
K21-034	NBR		34	44	5	6	4.5
K21-035	NBR	PU	35	50	10	11	5.5
K21-035/2	NBR	PU	35	45	10	11	4.5
K21-035/3	NBR	PU	35	55	10	11	6
K21-035/4	NBR	PU	35	55	12	13	6
K21-035/5	NBR	PU	35	43	6	7	4
K21-035/6	NBR	PU	35	52	12	13	6
K21-035/7	NBR	PU	35	45	6	7	4.5
K21-035/8	NBR	PU	35	47	6	7	5
K21-035/9	NBR	PU	35	50	7.5	8.5	5.5
K21-036	NBR	PU	36	51	10	11	5.5
K21-036/1	NBR	PU	36	51	7.1	8.1	5.5
K21-036/2	NBR	PU	36	50	8	9	5.5
K21-036/3	NBR	PU	36	46	7	8	4.5
K21-036/4	NBR	PU	36	48	6	7	5
K21-036/5	NBR	PU	36	46	6	7	4.5
K21-036/6	NBR		36	48	10	11	5
K21-036/7	NBR	PU	36	46	5	6	4.5
K21-037	NBR		37	45	5.5	6.5	4
K21-038	NBR	PU	38	52.5	9.5	10.5	5.5
K21-038/1	NBR	PU	38	55	10	11	6
K21-038/2	NBR	PU	38	58	10	11	6
K21-038/3	NBR	PU	38	50	6	7	5
K21-038/4	NBR	PU	38	50	10	11	5
K21-038/5	NBR	PU	38.1	50.8	6.35	7.35	5
K21-038/6	NBR	PU	38.1	50.8	7.14	8.14	5
K21-038/7		PU	38	45	6	7	3.5
K21-039/1		PU	39	58	10	11	6
K21-040	NBR	PU	40	55	10	11	5.5
K21-040/1	NBR	PU	40	50	6	7	4.5
K21-040/10	NBR	PU	40	50	5	6	4.5
K21-040/11	NBR	PU	40	50	8	9	4.5
K21-040/12	NBR	PU	40	65	10	11	7
K21-040/13	NBR	PU	40	56	8	9	6
K21-040/14	NBR	PU	40	48	11	12	4
K21-040/15	NBR	PU	40	55	7	8	5.5
K21-040/16	NBR	PU	40	52	6	7	5
K21-040/2	NBR	PU	40	50	10	11	4.5
K21-040/3	NBR	PU	40	52	12	13	5
K21-040/4	NBR	PU	40	60	10	11	6
K21-040/5	NBR	PU	40	60	12	13	6

KASTAŞ NO	NBR	PU	d (f7)/dp (h11)	Db (H11)/D (H11)	b	B (-0/+0.2)	n
K21-040/6	NBR	PU	40	50	9	10	4.5
K21-040/7	NBR	PU	40	50	7	8	4.5
K21-040/8	NBR	PU	40	56	10	11	6
K21-040/9	NBR		40	65	15	16	7
K21-041	NBR	PU	41.27	50.8	4.76	5.26	4
K21-042/1	NBR	PU	42	50	5	6	4
K21-042/2	NBR	PU	42	62	12	13	6
K21-042/3	NBR	PU	42	57	8	9	5.5
K21-042/4	NBR		42	55	8	9	5
K21-042/5	NBR	PU	42	50	8	9	4
K21-042/6	NBR	PU	42	51	11	12	4
K21-042/7	NBR	PU	42	52	10	11	4.5
K21-042/8	NBR	PU	42	50	6	7	4
K21-043	NBR	PU	43	63	10	11	6
K21-043/1	NBR		43	64	15	16	7
K21-044	NBR	PU	44	57	9	10	5
K21-045	NBR	PU	45	60	10	11	5.5
K21-045/1	NBR	PU	45	55	10	11	4.5
K21-045/10	NBR	PU	45	63	10	11	6
K21-045/11	NBR	PU	45	58	10	11	5
K21-045/12	NBR		45	56	7	8	5
K21-045/2	NBR	PU	45	57	6	7	5
K21-045/3	NBR	PU	45	63	12	13	6
K21-045/4	NBR	PU	45	65	10	11	6
K21-045/5	NBR	PU	45	65	12	13	6
K21-045/6	NBR	PU	45	70	12	13	7
K21-045/7	NBR	PU	45	55	6	7	4.5
K21-045/8	NBR	PU	45	53	7	8	4
K21-045/9	NBR	PU	45	53	8	9	4
K21-046		PU	46	70	12	13	7
K21-046/1	NBR	PU	46	58	6	7	5
K21-047	NBR	PU	47	65	12	13	6
K21-047/1		PU	47.62	63.5	11.5	12.5	6
K21-047/2	NBR		47	60	8	9	5
K21-048	NBR	PU	48	63	12	13	5.5
K21-048/1	NBR	PU	48	60	9	10	5
K21-048/2	NBR	PU	48	68	12	13	6
K21-048/3	NBR	PU	48	58	6.5	7.5	4.5
K21-048/4	NBR	PU	48	68	10	11	6
K21-048/5	NBR	PU	48	60	6	7	5
K21-048/6	NBR	PU	48	63	10	11	5.5
K21-050	NBR	PU	50	65	10	11	5.5
K21-050/1	NBR	PU	50	60	10	11	4.5
K21-050/11	NBR	PU	50	60	8	9	4.5
K21-050/12	NBR	PU	50	58	8	9	4
K21-050/13	NBR	PU	50	60	6	7	4.5
K21-050/14	NBR	PU	50	60	12	13	4.5
K21-050/15	NBR	PU	50	60	7	8	4.5
K21-050/16	NBR	PU	50	57	10	11	3.5
K21-050/17	NBR	PU	50.8	63.5	9.52	10.52	5
K21-050/18	NBR	PU	50	63	6	7	5
K21-050/19	NBR	PU	50	62	6	7	5
K21-050/2	NBR	PU	50	62	9	10	5
K21-050/20	NBR	PU	50	60	5	6	4.5
K21-050/21	NBR		50	60	4	5	4.5
K21-050/23	NBR	PU	50.8	60.3	4.76	5.76	4
K21-050/3	NBR	PU	50	63	8	9	5
K21-050/4	NBR	PU	50	63	9	10	5
K21-050/5	NBR	PU	50	65	12	13	5.5
K21-050/6	NBR	PU	50	68	12	13	6
K21-050/7	NBR	PU	50	70	8	9	6
K21-050/8	NBR	PU	50	70	10	11	6
K21-050/9	NBR	PU	50	70	12	13	6
K21-052	NBR	PU	52	62	12	13	4.5

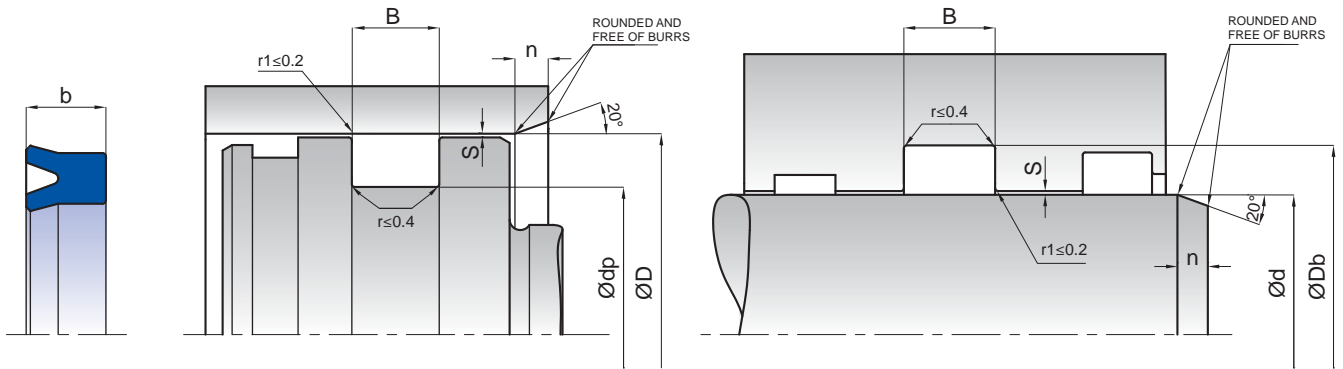

KASTAŞ NO	NBR	PU	d (f7)/dp (h11)	Db (H11)/D (H11)	b	B (-0/+0.2)	n
K21-052/1	NBR	PU	52	62	6	7	4.5
K21-053/2	NBR	PU	53	63	12	13	4.5
K21-053/3	NBR	PU	53	63	7.5	8.5	4.5
K21-053/4	NBR		53	64	5	6	5
K21-053/5	NBR		53	63	6	7	4.5
K21-053/6	NBR		53	63	10	11	4.5
K21-054	NBR		54	70	8	9	6
K21-055	NBR	PU	55	75	12	13	6
K21-055/1	NBR	PU	55	70	10	11	5.5
K21-055/3	NBR	PU	55	70	12	13	5.5
K21-055/4	NBR	PU	55	80	15	16	7
K21-055/5	NBR	PU	55	65	12	13	4.5
K21-055/6	NBR	PU	55	80	12	13	7
K21-055/7	NBR	PU	55	65	5	6	4.5
K21-055/8	NBR	PU	55	70	7.5	8.5	5.5
K21-055/9	NBR	PU	55	65	6	7	4.5
K21-056	NBR	PU	56	76	12	13	6
K21-056/2	NBR	PU	56	80	15	16	7
K21-056/3	NBR	PU	56	71	10	11	5.5
K21-056/4	NBR	PU	56	66	5	6	4.5
K21-056/5	NBR	PU	56	70	12	13	5.5
K21-056/6		PU	56	66	6	7	4.5
K21-057		PU	57.15	69.85	10	11	5
K21-057/1		PU	57.15	76.2	10	11	6
K21-058/1	NBR	PU	58	70	6	7	5
K21-058/2	NBR		58	78	12	13	6
K21-059	NBR		59	80	14	15	7
K21-060	NBR	PU	60	80	12	13	6
K21-060/1	NBR	PU	60	80	10	11	6
K21-060/2	NBR	PU	60	70	12	13	4.5
K21-060/3	NBR		60	80	16	17	6
K21-060/4	NBR	PU	60	75	12	13	5.5
K21-060/5	NBR	PU	60	70	13	14	4.5
K21-060/6	NBR	PU	60	70	6	7	4.5
K21-060/7	NBR	PU	60	70	7	8	4.5
K21-060/8	NBR		60	80	12.5	13.5	6
K21-061	NBR	PU	61	80	12	13	6
K21-061/1	NBR	PU	61	71	6	7	4.5
K21-063	NBR	PU	63	83	12	13	6
K21-063/1		PU	63.5	82.55	14.25	15.25	6
K21-063/2	NBR	PU	63	72	6	7	4
K21-063/3		PU	63	75	10	11	5
K21-063/4	NBR		63	78	8	9	5.5
K21-065	NBR	PU	65	85	12	13	6
K21-065/1	NBR	PU	65	80	12	13	5.5
K21-065/10		PU	65	75	7.3	8.3	4.5
K21-065/2	NBR	PU	65	90	8	9	7
K21-065/3	NBR	PU	65	90	13	14	7
K21-065/4	NBR	PU	65	90	15	16	7

KASTAŞ NO	NBR	PU	d (f7)/dp (h11)	Db (H11)/D (H11)	b	B (-0/+0.2)	n
K21-065/5	NBR	PU	65	75	10	11	4.5
K21-065/6	NBR		65	75	6	7	4.5
K21-065/7	NBR		65	90	12	13	7
K21-065/8	NBR	PU	65	75	12	13	4.5
K21-065/9	NBR	PU	65	80	10	11	5.5
K21-066	NBR	PU	66	77	6	7	5
K21-068	NBR		68	80	12	13	5
K21-068/2	NBR		68	80	10	11	5
K21-070	NBR	PU	70	90	12	13	6
K21-070/1	NBR	PU	70	80	12	13	4.5
K21-070/10		PU	70	80	8	9	4.5
K21-070/11	NBR		70	85	7.5	8.5	5.5
K21-070/2	NBR		70	85	8	9	5.5
K21-070/4	NBR	PU	70	85	12	13	5.5
K21-070/5	NBR	PU	70	80	5.4	6.4	4.5
K21-070/6	NBR		70	100	15	16	8
K21-070/7	NBR	PU	70	90	10	11	6
K21-070/8	NBR		70	80	7	8	4.5
K21-070/9	NBR	PU	70	80	6	7	4.5
K21-071/1	NBR		71.43	82.55	5.5	6.5	5
K21-072	NBR		72	80	10	11	4
K21-072/1	NBR	PU	72	90	10	12	6
K21-072/2	NBR		72	82	5	6	4.5
K21-075	NBR	PU	75	95	12	13	6
K21-075/1	NBR	PU	75	85	12	13	4.5
K21-075/2	NBR	PU	75	90	12	13	5.5
K21-075/3		PU	75	90	10	11	5.5
K21-075/4	NBR		75	83	12	13	4
K21-075/5	NBR		75	95	10	11	6
K21-075/6		PU	75	85	7	8	4.5
K21-075/7	NBR		75	100	15	16	7
K21-075/8		PU	75	85	6	7	4.5
K21-076		PU	76.2	95.25	10	11	6
K21-076/2	NBR		76.2	88.9	6.35	7.35	5
K21-078	NBR		78	88	5	6	4.5
K21-080	NBR	PU	80	100	12	13	6
K21-080/1	NBR	PU	80	95	8	9	5.5
K21-080/10	NBR	PU	80	90	6	7	4.5
K21-080/11	NBR	PU	80	90	5	6	4.5
K21-080/12	NBR		80	105	12	13	7
K21-080/13	NBR		80	100	12.5	13.5	6
K21-080/2	NBR	PU	80	95	9	10	5.5
K21-080/3	NBR	PU	80	95	12	13	5.5
K21-080/4		PU	80	90	5.4	6.4	4.5
K21-080/5	NBR	PU	80	100	10	11	6
K21-080/6	NBR	PU	80	105	15	16	7
K21-080/7	NBR		80	90	7	8	4.5
K21-080/8	NBR		80	100	15	16	6
K21-080/9		PU	80	90	10	11	4.5
K21-082/1	NBR	PU	82	92	10	11	4.5
K21-082/2	NBR		82	108	12	13	7
K21-082/3		PU	82.55	101.6	14.8	15.8	6
K21-082/4		PU	82	102	10	11	6
K21-083	NBR	PU	83	103	14	15	6
K21-084	NBR		84	103	14	15	6
K21-085	NBR	PU	85	105	12	13	6
K21-085/10		PU	85	102	9	10	6
K21-085/2	NBR	PU	85	100	12	13	5.5
K21-085/3	NBR	PU	85	95	9	10	4.5
K21-085/4	NBR		85	105	15	16	6
K21-085/5	NBR		85	105	10	11	6
K21-085/6		PU	85	110	12	13	7
K21-085/7	NBR		85	110	15	16	7
K21-085/8	NBR	PU	85	100	9	10	5.5
K21-085/9		PU	85	100	25	26	5.5

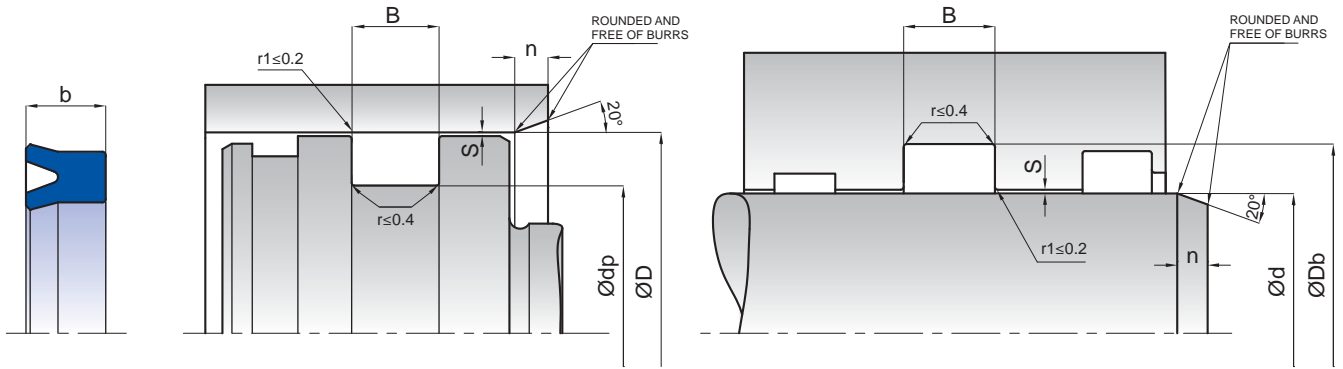

KASTAŞ NO	NBR	PU	d (f7)/dp (h11)	Db (H11)/D (H11)	b	B (-0/+0.2)	n
K21-086	NBR		86	105	16	17	6
K21-088		PU	88.9	107.95	12.7	13.7	6
K21-090	NBR	PU	90	110	12	13	6
K21-090/10		PU	90	100	6.8	7.8	4.5
K21-090/11		PU	90	120	15	16	8
K21-090/12	NBR	PU	90	105	9	10	5.5
K21-090/13	NBR		90	100	5	6	4.5
K21-090/2	NBR	PU	90	100	8	9	4.5
K21-090/3	NBR	PU	90	110	10	11	6
K21-090/4	NBR	PU	90	110	15	16	6
K21-090/5	NBR		90	112	12	13	7
K21-090/6	NBR	PU	90	115	12	13	7
K21-090/7		PU	90	105	12	13	5.5
K21-090/8	NBR		90	105	7.5	8.5	5.5
K21-090/9	NBR		90	100	4	5	4.5
K21-092	NBR		92	111.1	15	16	6
K21-095	NBR		95	103	12	13	4
K21-095/1		PU	95	110	10	11	5.5
K21-095/2	NBR	PU	95	115	12	13	6
K21-095/3	NBR	PU	95	115	15	16	6
K21-095/4	NBR	PU	95	120	12	13	7
K21-095/5	NBR		95	125	15	16	8
K21-095/6	NBR	PU	95	110	9	10	5.5
K21-095/7		PU	95	110	12	13	5.5
K21-096		PU	96	105	11	12	4
K21-100	NBR	PU	100	125	15	16	7
K21-100/1	NBR	PU	100	120	12	13	6
K21-100/2	NBR	PU	100	120	15	16	6
K21-100/3	NBR	PU	100	130	18	19	8
K21-100/4	NBR		100	120	10	11	6
K21-100/5	NBR	PU	100	110	5	6	4.5
K21-100/6	NBR	PU	100	130	15	16	8
K21-100/7		PU	100	110	8	9	4.5
K21-100/9	NBR	PU	100	115	9	10	5.5
K21-101		PU	101.6	127	19.5	20.5	7
K21-103	NBR		103	125	14	15	7
K21-104	NBR		104.77	127	15.87	16.87	7
K21-105	NBR	PU	105	130	15	16	7
K21-105/1		PU	105	120	8	9	5.5
K21-105/2		PU	105	130	18	19	7
K21-105/3		PU	105	120	15	16	5.5
K21-107	NBR		107	127	16	17	6
K21-107/1		PU	107.95	120.65	14	15	5
K21-107/2		PU	107	130	15	16	7
K21-110	NBR	PU	110	135	18	19	7
K21-110/1	NBR	PU	110	140	18	19	8
K21-110/2	NBR	PU	110	125	12	13	5.5
K21-110/3		PU	110	130	10	11	6
K21-110/4		PU	110	120	8	9	4.5

KASTAŞ NO	NBR	PU	d (f7)/dp (h11)	Db (H11)/D (H11)	b	B (-0/+0.2)	n
K21-110/5		PU	110	130	15	16	6
K21-111	NBR		111	130.1	15	16	6
K21-112	NBR		112	125	9	10	5
K21-112/1		PU	112	125	9	10	5
K21-114/1		PU	114.8	125	5.7	6.7	4.5
K21-115	NBR	PU	115	140	18	19	7
K21-115/2	NBR	PU	115	125	8	9	4.5
K21-115/3	NBR	PU	115	135	15	16	6
K21-115/4	NBR		115	123	12	13	4
K21-115/5	NBR	PU	115	130	10	11	5.5
K21-115/6		PU	115	125	15	16	4.5
K21-118	NBR		118	132	8.5	9.5	5.5
K21-120	NBR	PU	120	145	18	19	7
K21-120/1	NBR	PU	120	150	15	16	8
K21-120/2		PU	120	132	10	11	5
K21-120/3		PU	120	150	18	19	8
K21-120/4		PU	120	140	10	11	6
K21-120/5	NBR		120	140	14	15	6
K21-120/6		PU	120	130	7	8	4.5
K21-120/7		PU	120	140	15	16	6
K21-120/8		PU	120	135	15	16	5.5
K21-125	NBR	PU	125	155	18	19	8
K21-125/1	NBR	PU	125	150	18	19	7
K21-125/2	NBR		125	154	20	21	8
K21-125/3		PU	125	140	11	12	5.5
K21-125/4		PU	125	145	15	16	6
K21-125/5	NBR		125	155	15	16	8
K21-125/6		PU	125	145	10	11	6
K21-125/7	NBR	PU	125	140	9	10	5.5
K21-125/8		PU	125	140	8.5	9.5	5.5
K21-127		PU	127	139.7	10	11	5
K21-127/1	NBR	PU	127	151	16	17	7
K21-127/2		PU	127	152.4	19.5	20.5	7
K21-130	NBR	PU	130	150	15	16	6
K21-130/1	NBR	PU	130	160	18	19	8
K21-130/2		PU	130	140	8	9	4.5
K21-130/3	NBR		130	160	15	16	8
K21-130/4		PU	130	152	13	14	7
K21-132/1		PU	132	145	8.5	9.5	5
K21-133	NBR		133	152.5	15	16	6
K21-135	NBR		135	143	12	13	4
K21-135/1	NBR	PU	135	150	15	16	5.5
K21-135/2	NBR	PU	135	165	15	16	8
K21-136		PU	136	150	9	10	5.5
K21-139	NBR		139.7	152.4	6.35	7.35	5
K21-140	NBR	PU	140	170	18	19	8
K21-140/1		PU	140	160	15	16	6
K21-140/2	NBR	PU	140	160	8	9	6
K21-140/3		PU	140	160	10	11	6
K21-140/4		PU	140	165	18	19	7
K21-140/5	NBR		140	154	10	11	5.5
K21-140/6		PU	140	155	9	10	5.5
K21-145	NBR	PU	145	160	8	9	5.5
K21-145/1	NBR	PU	145	170	18	19	7
K21-145/2	NBR	PU	145	175	18	19	8
K21-145/3	NBR		145	165	15	16	6
K21-145/4		PU	145	160	9	10	5.5
K21-149		PU	149.22	187.32	15.87	16.87	10
K21-150	NBR	PU	150	180	18	19	8
K21-150/3		PU	150	170	15	16	6
K21-150/4	NBR	PU	150	180	15	16	8
K21-150/5	NBR		150	170	10	11	6
K21-150/6	NBR		150	165	9	10	5.5
K21-152	NBR	PU	152	177.8	19.5	20.5	7
K21-155	NBR		155	163	12	13	4

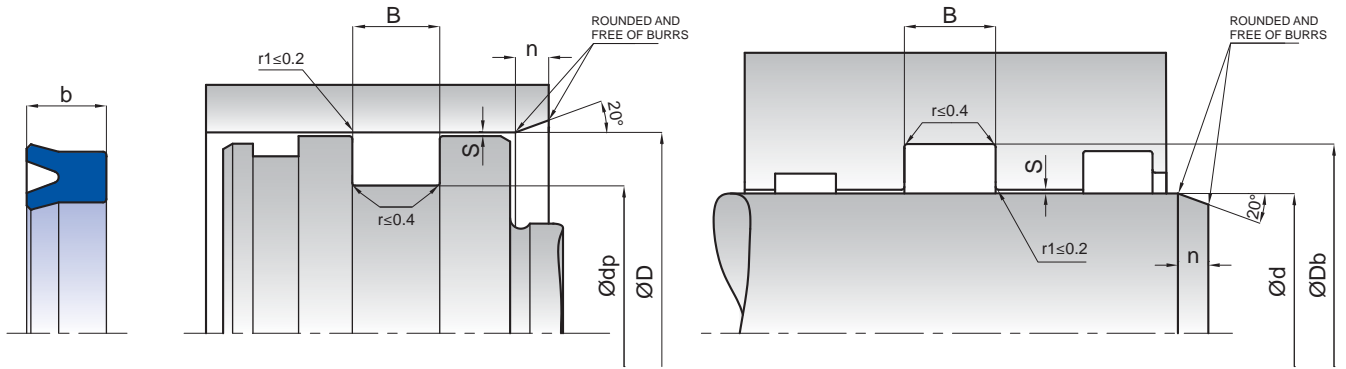

KASTAŞ NO	NBR	PU	d (f7)/dp (h11)	Db (H11)/D (H11)	b	B (-0/+0.2)	n
K21-155/1	NBR	PU	155	175	15	16	6
K21-155/2		PU	155	180	15	16	7
K21-160	NBR	PU	160	190	22	23	8
K21-160/1	NBR	PU	160	180	15	16	6
K21-160/3	NBR	PU	160	195	17	18	9
K21-160/4	NBR		160	168	12	13	4
K21-160/5		PU	160	170	5	6	4.5
K21-160/6	NBR		160	169	13.5	14.5	4
K21-160/7	NBR		160	180	10	11	6
K21-165		PU	165	185	15	16	6
K21-165/1		PU	165	195	20	21	8
K21-165/2		PU	165	180	9.5	10.5	5.5
K21-168	NBR	PU	168	180	14	15	5
K21-170	NBR	PU	170	200	15	16	8
K21-170/1	NBR	PU	170	200	22	23	8
K21-170/2		PU	170	190	15	16	6
K21-170/3		PU	170	183	13	14	5
K21-175		PU	175	215	20	21	9
K21-175/1		PU	175	200	15	16	7
K21-175/2		PU	175	195	15	16	6
K21-177	NBR	PU	177	203.2	22.7	23.7	7
K21-180	NBR	PU	180	210	22	23	8
K21-180/1		PU	180	200	15	16	6
K21-180/2		PU	180	205	15	16	7
K21-180/3		PU	180	200	12	13	6
K21-185	NBR	PU	185	195	12	13	4.5
K21-185/1	NBR	PU	185	200	9	10	5.5
K21-190	NBR	PU	190	220	25	26	8
K21-190/1		PU	190	210	15	16	6
K21-190/2	NBR		190	215	20	21	7
K21-195	NBR		195	220	16	17	7
K21-196	NBR	PU	196	228.6	25.8	26.8	8
K21-200	NBR	PU	200	230	22	23	8
K21-200/2		PU	200	240	20	21	9
K21-200/3		PU	200	235	20	21	9
K21-200/4		PU	200	220	15	16	6
K21-200/5		PU	200	230	18	19	8
K21-200/6	NBR		200	230	15	16	8
K21-200/7		PU	200	220	12	13	6
K21-200/8		PU	200	225	15	16	7
K21-210		PU	210	230	15	16	6
K21-210/1		PU	210	240	18	19	8
K21-215	NBR		215	230	7.5	8.5	5.5
K21-215/1		PU	215	245	18	19	8
K21-220	NBR	PU	220	250	20	21	8
K21-220/2		PU	220	250	15	16	8
K21-220/3		PU	220	250	18	19	8
K21-225	NBR		225	250	18	19	7
K21-225/1		PU	225	250	15	16	7

KASTAŞ NO	NBR	PU	d (f7)/dp (h11)	Db (H11)/D (H11)	b	B (-0/+0.2)	n
K21-225/2		PU	225	242	11	12	6
K21-230		PU	230	250	15	16	6
K21-230/1		PU	230	260	18	19	8
K21-230/2		PU	230	250	12	13	6
K21-235		PU	235	255	12	13	6
K21-240	NBR	PU	240	260	16	17	6
K21-240/1	NBR	PU	240	270	18	19	8
K21-240/3		PU	240	265	18	19	7
K21-245		PU	245	275	18	19	8
K21-250		PU	250	270	15	16	6
K21-250/1		PU	250	275	19	20	7
K21-250/2		PU	250	280	22	23	8
K21-250/3		PU	250	280	18	19	8
K21-250/4	NBR		250	275	12	13	7
K21-260		PU	260	290	18	19	8
K21-269	NBR		269	290	12	13	7
K21-270		PU	270	300	18	19	8
K21-270/1	NBR		270	300	22	23	8
K21-270/2	NBR		270	290	12	13	6
K21-270/3		PU	270	300	19	20	8
K21-280	NBR		280	310	15	16	8
K21-280/1		PU	280	300	15	16	6
K21-290		PU	290	310	12	13	6
K21-290/1	NBR		290	307	14	15	6
K21-300		PU	300	330	17	18	8
K21-300/1	NBR	PU	300	320	15	16	6
K21-300/2		PU	300	330	19	20	8
K21-310		PU	310	330	15	16	6
K21-319	NBR		319	340	12	13	7
K21-320	NBR	PU	320	350	15	16	8
K21-320/1	NBR		320	340	12	13	6
K21-320/2		PU	320	350	19	20	8
K21-325		PU	325	360	20	21	9
K21-340		PU	340	360	15	16	6
K21-360	NBR		360	420	30	31	15
K21-360/1		PU	360	380	16	17	6
K21-375	NBR	PU	375	395	12	13	6
K21-390	NBR		390	406	14	15	6
K21-400	NBR		400	420	15	16	6
K21-400/1		PU	400	425	19	20	7
K21-430		PU	430	450	15	16	6
K21-450	NBR		450	480	15	16	8

Please contact our customer service
for the dimensions out of our stock list.



K36 is a single acting piston - rod seal which consists of reinforced cotton fabric and nitrile rubber vulcanized together forming an integral sealing element.

PRODUCT ADVANTAGES

- Functions even with poor surfaces
- Reinforced cotton fabric base prevents the seal from extrusion
- Both rod and piston application
- Good sealing at low pressures

APPLICATION

Low to medium duty hydraulic cylinders, mobile hydraulics and presses.

MATERIAL	CODE	
NBR	80 SHORE A	NB8001
COTTON FABRIC NBR		NB8008

OPERATING CONDITIONS			
MEDIA	Mineral oils (DIN 51524)	HFA and HFB	HFC
TEMPERATURE	-30°C +105°C	+5°C +60°C	-30°C +60°C
PRESSURE	≤250 Bar	≤250 Bar	≤250 Bar
SPEED	≤0.5 m/sec	≤0.5 m/sec	≤0.5 m/sec

Note: The above data are maximum values and cannot be used at the same time.

SURFACE ROUGHNESS		Ra	Rmax
Sliding Surface	ØD-Ød	≤0.4 µm	≤3.2 µm
Groove Base	Ødp-ØDb	≤1.8 µm	≤6.3 µm
Groove Flanks	B	≤3.2 µm	≤16 µm

Note: It is recommended to have 50% to 90% of the working surface material contact area value.

INSTALLATION

K36 is to be assembled into open grooves. It is very important that the assembly tools must be of soft material and have no sharp edges. Before installation the sealing element must be oiled with system oil.

NOTES

The permissible sealing gap values of K36 piston - rod seal is given in the below table.

PERMISSIBLE SEALING GAP	
Pressure (Bar)	S (mm)
150	0.2
250	0.1

Note: The largest sealing gap value occurring on the non-pressurized side of the seal does have a vital importance for the function of the seal and in this respect it is quite important to use the S value lower than the above indicated numbers.

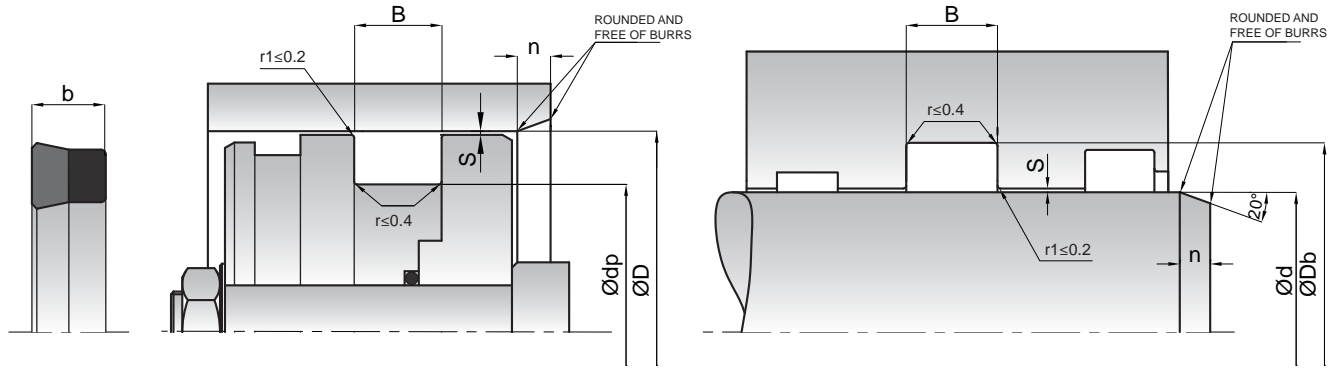

KASTAŞ NO	d (h9)/dp (f8)	Db (H11)/D(H9)	B (-0/+0.2)	b	n
K36-004	4	12	6.3	6	5
K36-010	10	17	6.3	6	5
K36-010/1	10	19	6.3	6	5
K36-012	12	20	6.3	6	5
K36-014	14	22	6.3	6	5
K36-014/1	14	22	7	6.7	5
K36-015	15	23	6.3	6	5
K36-016	16	24	6.3	6	5
K36-016/1	16	24	6.5	6.2	5
K36-016/1	16	24	6.5	6.2	5
K36-016/2	16	24	7	6.7	5
K36-018	18	26	6.3	6	5
K36-018/1	18	24	5.2	4.9	5
K36-019	19.5	27.5	8.3	8	5
K36-020	20	28	6.3	6	5
K36-020/1	20	26	5.5	5.2	5
K36-020/2	20	27	6.5	6.2	5
K36-020/3	20	28	7	6.7	5
K36-020/4	20	30	8.5	8.2	5
K36-022	22	30	6.3	6	5
K36-022/1	22	30	6.5	6.2	5
K36-022/2	22	30	7	6.7	5
K36-022/3	22	32	7.3	7	5
K36-025	25	32	6.3	6	5
K36-025/1	25	33	6.3	6	5
K36-025/2	25	33	6	5.7	5
K36-025/3	25	35	8.3	8	5
K36-025/5	25	35	9	8.7	5
K36-025/7	25.4	31.75	4.76	4.46	5
K36-028	28	36	6.3	6	5
K36-028/1	28	43	11	10.7	5
K36-028/3	28	36	6.4	6.1	5
K36-028/4	28.57	41.27	10	9.7	5
K36-030	30	38	6.3	6	5
K36-030/1	30	38	6	5.7	5
K36-030/2	30	40	6.3	6	5
K36-030/3	30	40	7.5	7.2	5
K36-030/4	30	40	7	6.7	5
K36-030/5	30	50	14.5	14.2	5
K36-030/7	30	37.5	6.5	6.2	5
K36-030/6	30	38	6.4	6.1	5
K36-031	31.75	47.62	11.6	11.3	5
K36-032	32	40	6.3	6	5
K36-032/1	32	44	12.5	12.2	5
K36-035	35	43	6.3	6	5
K36-035/1	35	45	8	7.7	5
K36-035/2	35	43	6	5.7	5
K36-035/4	35	43	6.5	6.2	5
K36-035/5	35	43	7.3	7	5

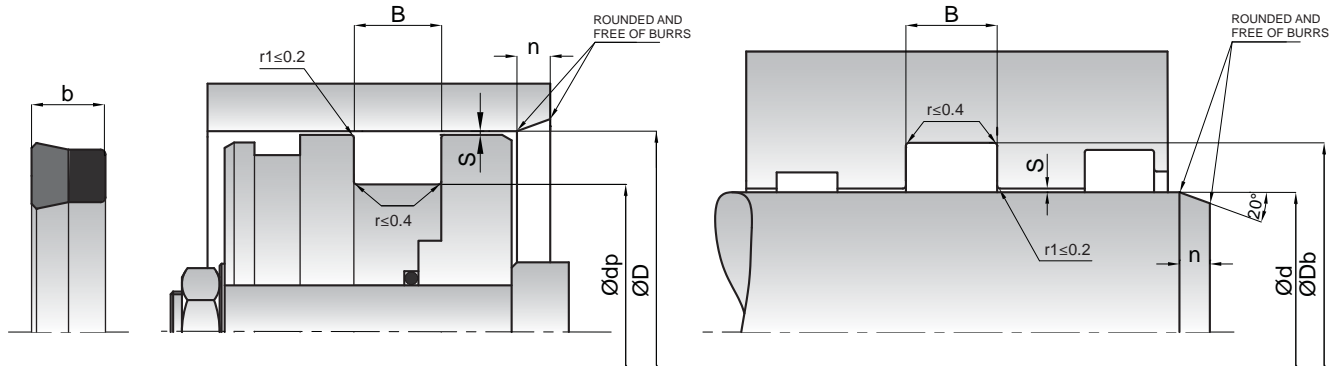

KASTAŞ NO	db (h9)/dp (f8)	Db (H11)/Dp(H9)	B (-0/+0.2)	b	n
K36-035/6	35	45	7.5	7.2	5
K36-035/3	35	50	11.5	11.2	5
K36-036	36	44	6.3	6	5
K36-036/1	36	51	11	10.7	5
K36-038	38	50	9.5	9.2	5
K36-038/1	38.1	50.8	12.4	12.1	5
K36-040	40	48	6.3	6	5
K36-040/1	40	50	8	7.7	5
K36-040/2	40	48	8	7.7	5
K36-040/7	40	48	7.3	7	5
K36-040/3	40	50	7	6.7	5
K36-040/6	40	50	11	10.7	5
K36-040/5	40	60	14.5	14.2	5
K36-042	42	50	6.3	6	5
K36-045	45	53	8.5	8.2	5
K36-045/1	45	55	8	7.7	5
K36-045/2	45	55	10.5	10.2	5
K36-045/3	45	60	11	10.7	5
K36-045/4	45	57	9.5	9.2	5
K36-045/6	45	53	6.3	6	5
K36-045/5	45	65	14.5	14.2	5
K36-046	46	56	8	7.7	5
K36-048	48	60	10	9.7	5
K36-050	50	62	9.5	9.2	5
K36-050/1	50	60	7.5	7.2	5
K36-050/2	50	60	8	7.7	5
K36-050/3	50	60	10	9.7	5
K36-050/4	50	70	14.5	14.2	5
K36-055	55	65	8	7.7	5
K36-055/1	55	67	10.5	10.2	5
K36-055/3	55	63	8.3	8	5
K36-055/2	55	70	10.5	10.2	5
K36-056	56	66	8	7.7	5
K36-056/1	56	76	14	13.7	5
K36-060	60	70	8	7.7	5
K36-060/1	60	70	7.5	7.2	5
K36-060/2	60	72	9.5	9.2	5
K36-060/3	60	80	12.5	12.2	5
K36-060/4	60	72	10	9.7	5
K36-060/5	60	75	13	12.7	5
K36-060/6	60	80	14.5	14.2	5
K36-063	63.5	82.55	14.28	13.98	5
K36-065	65	73	9.6	9.3	5
K36-065/1	65	77	9.6	9.3	5
K36-070	70	80	7.5	7.2	5
K36-070/1	70	82	9.6	9.3	5
K36-070/2	70	82	9	8.7	5
K36-070/3	70	90	14	13.7	5
K36-070/4	70	85	8	7.7	5



K95 is a single acting piston - rod seal and designed to have symmetrical lips in order to be used both for rod and piston applications.

PRODUCT ADVANTAGES

- Superior static and dynamic sealing effect
- Wide range of dimensions
- Easy assembly into closed grooves
- Although designed for hydraulic cylinders, it is used in special pneumatic cylinders as well
- Simple groove design
- Economical sealing solution

APPLICATION

Fork-lift trucks, injection moulding machines, agricultural machinery, and standard cylinders.

MATERIAL	CODE	
NBR	90 SHORE A	NB9001

OPERATING CONDITIONS			
MEDIUM	Mineral oils (DIN 51524)	HFA and HFB	HFC
TEMPERATURE	-30°C +105°C	+5°C +60°C	-30°C +60°C
PRESSURE	≤150 Bar	≤150 Bar	≤150 Bar
SPEED	≤0.5 m/sec	≤0.5 m/sec	≤0.5 m/sec

Note: The above data are maximum values and cannot be used at the same time.

SURFACE ROUGHNESS		Ra	Rmax
Sliding Surface	$\varnothing D - \varnothing d$	≤0.4 μm	≤3.2 μm
Groove Base	$\varnothing dp - \varnothing Db$	≤1.6 μm	≤10 μm
Groove Flanks	B	≤3.2 μm	≤16 μm

Note: It is recommended to have 50% to 90% of the working surface material contact area value.

INSTALLATION

Easily assembled into closed grooves according to the minimum diameter values that are given in the below table. Open grooves or special assembly tools should be used for the values that are outside this table. Before installation the sealing element must be oiled with system oil.

MINIMUM DIAMETER VALUES FOR CLOSED TYPE OF GROOVES

$(D-d)/2$ (mm)	4	5	6	7.7	10	12.5	15
d min (mm)	25	30	40	50	80	100	105

NOTES

For special applications that require high temperatures, K95 can be produced in FKM material. The permissible sealing gap values of K95 piston - rod seal is given in the below table.

PERMISSIBLE SEALING GAP			
	Smax (mm)		
$t=(D-d)/2$	50 bar	100 bar	150 bar
$t \leq 5$	0.40	0.20	0.10
$t > 5$	0.45	0.25	0.15

Note: The largest sealing gap value occurring on the non-pressurized side of the seal does have a vital importance for the function of the seal and in this respect it is quite important to use the S value lower than the above indicated numbers.

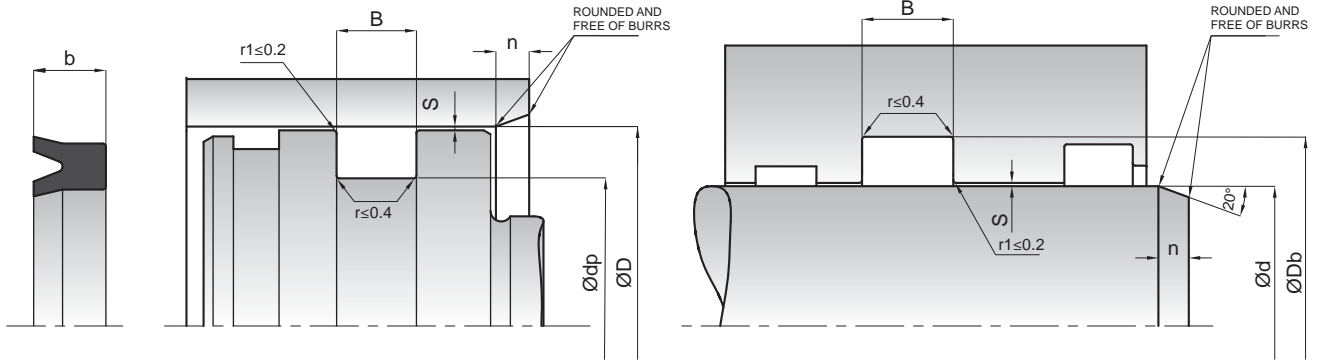

KASTAŞ NO	d (f7)/dp (h11)	Db (H11)/D (H11)	b	B (-0/+0.2)	n
K95-004	4	10	4	4.5	3
K95-006	6	12	4	4.5	3
K95-006/1	6	15	5	6	4
K95-006/3	6	16	6	7	4.5
K95-007	7	15	5	6	4
K95-007/1	7.94	12.7	3.5	4	2
K95-008	8	14	4	4.5	3
K95-008/1	8	14.2	3.5	4	3
K95-008/2	8	16	3.5	4	4
K95-008/3	8	16	4.2	4.7	4
K95-008/4	8	12	4	4.5	2
K95-010	10	14	2	2.5	2
K95-010/1	10	16	4	4.5	3
K95-010/3	10	18	5	6	4
K95-010/4	10	22	6	7	5
K95-010/5	10	19	3.5	4	4
K95-010/6	10	20	3.5	4	4.5
K95-010/7	10	23	4.5	5	5
K95-012	12	18	4	4.5	3
K95-012/1	12	20	5.5	6.5	4
K95-012/3	12	22	5	6	4.5
K95-012/4	12	24	6	7	5
K95-012/7	12.5	20.3	3.5	4	4
K95-012/6	12.5	20	4.5	5	4
K95-012/5	12.5	23	3.5	4	4.5
K95-014	14	20	4	4.5	3
K95-014/1	14	20	4.8	5.3	3
K95-014/2	14	25	3.5	4	4.5
K95-015	15	22	4	4.5	3
K95-015/1	15	24	7	8	4
K95-015/2	15	25	6	7	4.5
K95-016	16	22	4	4.5	3
K95-016/1	16	22	6	7	3
K95-016/2	16	25	5	6	4
K95-016/3	16	26	5	6	4.5
K95-018	18	26	4	4.5	4
K95-018/1	18	24	4	4.5	3
K95-018/2	18	25	4	4.5	3
K95-020	20	28	4	4.5	4
K95-020/1	20	28	8	9	4
K95-020/3	20	30	8	9	4.5
K95-020/5	20	35	10	11	5.5
K95-020/6	20	32	7.5	8.5	5
K95-022	22	30	6	7	4
K95-022/1	22	35	7	8	5
K95-022/2	22	32	5	6	4.5
K95-022/3	22	28	5	6	3
K95-024	24	30	5	6	3
K95-024/1	24	32	4	4.5	4

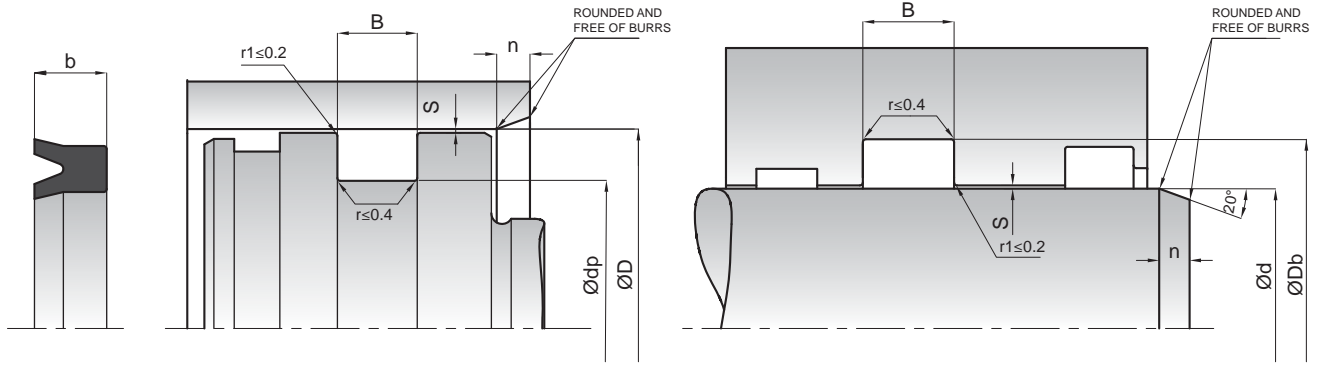

KASTAŞ NO	d (f7)/dp (h11)	Db (H11)/D (H11)	b	B (-0/+0.2)	n
K95-024/2	24	34	5	6	4.5
K95-025	25	33	7	8	4
K95-025/1	25	40	6	7	5.5
K95-027	27	36	6	7	4
K95-028	28	38	5	6	4.5
K95-028/2	28	52	10	11	7
K95-029	29	35	6	7	3
K95-030	30	40	9	10	4.5
K95-030/1	30	45	10	11	5.5
K95-030/2	30	55	12	13	7
K95-032	32	42	8	9	4.5
K95-032/1	32	40	7	8	4
K95-032/2	32	48	8	9	5.5
K95-033	33	42	7	8	4
K95-035	35	45	5	6	4.5
K95-035/1	35	45	6	7	4.5
K95-040	40	50	5	6	4.5
K95-040/2	40	48	8	9	4
K95-040/1	40	60	10	11	7
K95-046	46	70	12	13	7
K95-048	48	60	6	7	5
K95-048/1	48	60	7	8	5
K95-050/1	50	75	12	13	7
K95-050	50	80	15	16	8
K95-055	55	70	10	11	5.5
K95-058	58	70	6	7	5
K95-060	60	100	20	21	10
K95-062	62	86	12	13	7
K95-064	64	80	8	9	5.5
K95-072	72	84	8	9	5
K95-072/1	72	84	6	7	5
K95-075	75	100	12	13	7
K95-075/1	75	90	7.5	8.5	5.5
K95-130	130	150	10	11	7
K95-135	135	150	10	11	5.5
K95-230	230	270	20	21	10
K95-290	290	330	20	21	10



20 horizontal light gray lines for writing.



KX is a double acting X-ring with special design lip to be used both for rod and piston applications.

PRODUCT ADVANTAGES

- Can be used both for reciprocating and rotating hydraulic applications
- Low friction compared to o-rings
- No tool parting line on the dynamic surface
- No twisting in the groove
- Both for rod and piston application
- Economical sealing solution at low pressures

APPLICATION

Hydraulic and pneumatic valves, light duty cylinders, flanges and heavy duty applications.

MATERIAL		CODE
NBR	70 SHORE A	NB7001

OPERATING CONDITIONS			
MEDIA	Mineral oils (DIN 51524)	HFA and HFB	HFC
TEMPERATURE	-30°C +105°C	+5°C +60°C	-30°C +60°C
SPEED	≤0.5 m/sec	≤0.5 m/sec	≤0.5 m/sec

Note: The above data are maximum values and cannot be used at the same time.

SURFACE ROUGHNESS	Ra	Rmax
Sliding Surface	≤0.6 μm	≤3.2 μm
Groove Base	≤2.5 μm	≤10 μm
Groove Flanks	≤5 μm	≤18 μm

Note: It is recommended to have 50% to 90% of the working surface material contact area value.

INSTALLATION

X-ring is assembled into the groove by hand. It is very important that the assembly tools must be of soft material and have no sharp edges. Before installation the seal must be oiled with system oil.

NOTES

For special applications that require high temperatures, KX can be produced in FKM. It can be used up to 400 bar with a back-up ring.

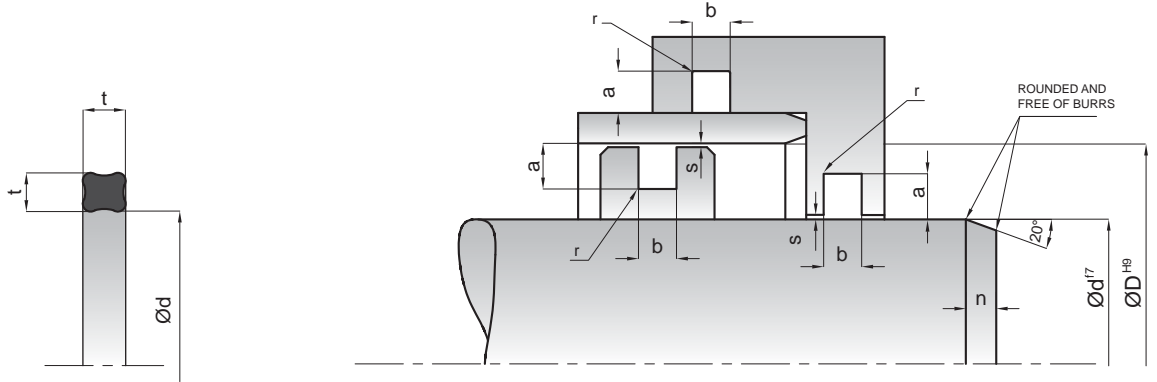

KASTAŞ NO	d	t	a (static)	a (dynamic)	b (-0/+0.2)	r	s
KX-0044817	4.48	1.78	1.4	1.5	2	0.2	0.05
KX-0060717	6.07	1.78	1.4	1.5	2	0.2	0.05
KX-0082017	8.2	1.78	1.4	1.5	2	0.2	0.05
KX-0076617	7.66	1.78	1.4	1.5	2	0.2	0.05
KX-0092517	9.25	1.78	1.4	1.5	2	0.2	0.05
KX-0124217	12.42	1.78	1.4	1.5	2	0.2	0.05
KX-0140017	14	1.78	1.4	1.5	2	0.2	0.05
KX-0156017	15.6	1.78	1.4	1.5	2	0.2	0.05
KX-0171717	17.17	1.78	1.4	1.5	2	0.2	0.05
KX-0203517	20.35	1.78	1.4	1.5	2	0.2	0.05
KX-0235217	23.52	1.78	1.4	1.5	2	0.2	0.05
KX-0251217	25.12	1.78	1.4	1.5	2	0.2	0.05
KX-0267017	26.7	1.78	1.4	1.5	2	0.2	0.05
KX-0298717	29.87	1.78	1.4	1.5	2	0.2	0.05
KX-0346517	34.65	1.78	1.4	1.5	2	0.2	0.05
KX-0378217	37.82	1.78	1.4	1.5	2	0.2	0.05
KX-0441717	44.17	1.78	1.4	1.5	2	0.2	0.05
KX-0473517	47.35	1.78	1.4	1.5	2	0.2	0.05
KX-0505217	50.52	1.78	1.4	1.5	2	0.2	0.05
KX-0537017	53.7	1.78	1.4	1.5	2	0.2	0.05
KX-0568717	56.87	1.78	1.4	1.5	2	0.2	0.05
KX-0600517	60.05	1.78	1.4	1.5	2	0.2	0.05
KX-0632217	63.22	1.78	1.4	1.5	2	0.2	0.05
KX-0695717	69.57	1.78	1.4	1.5	2	0.2	0.05
KX-0727517	72.75	1.78	1.4	1.5	2	0.2	0.05
KX-0759217	75.92	1.78	1.4	1.5	2	0.2	0.05
KX-0822717	82.27	1.78	1.4	1.5	2	0.2	0.05
KX-0886217	88.62	1.78	1.4	1.5	2	0.2	0.05
KX-0949717	94.97	1.78	1.4	1.5	2	0.2	0.05
KX-1013217	101.32	1.78	1.4	1.5	2	0.2	0.05
KX-1076717	107.62	1.78	1.4	1.5	2	0.2	0.05
KX-1140217	114.02	1.78	1.4	1.5	2	0.2	0.05
KX-1203717	120.37	1.78	1.4	1.5	2	0.2	0.05
KX-0107826	10.78	2.62	2.25	2.3	3	0.3	0.08
KX-0123726	12.37	2.62	2.25	2.3	3	0.3	0.08
KX-0139526	13.95	2.62	2.25	2.3	3	0.3	0.08
KX-0155426	15.54	2.62	2.25	2.3	3	0.3	0.08
KX-0187226	18.72	2.62	2.25	2.3	3	0.3	0.08
KX-0202926	20.29	2.62	2.25	2.3	3	0.3	0.08
KX-0711226	71.12	2.62	2.25	2.3	3	0.3	0.08
KX-0758726	75.87	2.62	2.25	2.3	3	0.3	0.08
KX-0822226	82.22	2.62	2.25	2.3	3	0.3	0.08
KX-0885726	88.57	2.62	2.25	2.3	3	0.3	0.08
KX-0949226	92.92	2.62	2.25	2.3	3	0.3	0.08
KX-1012726	101.27	2.62	2.25	2.3	3	0.3	0.08
KX-1076226	107.62	2.62	2.25	2.3	3	0.3	0.08
KX-1139726	113.97	2.62	2.25	2.3	3	0.3	0.08
KX-1203226	120.32	2.62	2.25	2.3	3	0.3	0.08
KX-1266726	126.67	2.62	2.25	2.3	3	0.3	0.08

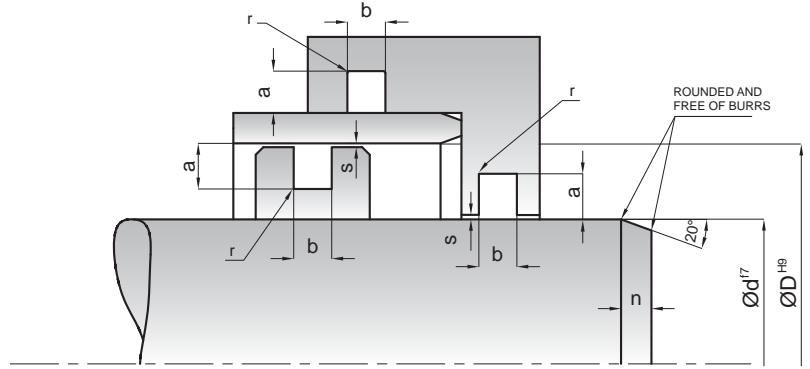
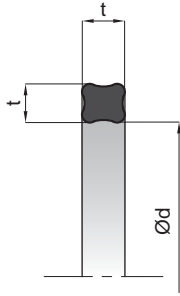

KASTAŞ NO	d	t	a (static)	a (dynamic)	b (-0/+0.2)	r	s
KX-1393726	139.37	2.62	2.25	2.3	3	0.3	0.08
KX-1457226	145.72	2.62	2.25	2.3	3	0.3	0.08
KX-1584226	158.42	2.62	2.25	2.3	3	0.3	0.08
KX-1711126	171.11	2.62	2.25	2.3	3	0.3	0.08
KX-1774726	177.47	2.62	2.25	2.3	3	0.3	0.08
KX-1901726	190.17	2.62	2.25	2.3	3	0.3	0.08
KX-1965226	196.52	2.62	2.25	2.3	3	0.3	0.08
KX-2028726	202.87	2.62	2.25	2.3	3	0.3	0.08
KX-2155726	262.57	2.62	2.25	2.3	3	0.3	0.08
KX-2219226	221.92	2.62	2.25	2.3	3	0.3	0.08
KX-2346226	234.62	2.62	2.25	2.3	3	0.3	0.08
KX-0202235	20.22	3.53	3.1	3.2	4	0.4	0.08
KX-0234035	23.4	3.53	3.1	3.2	4	0.4	0.08
KX-0249935	24.99	3.53	3.1	3.2	4	0.4	0.08
KX-0281735	28.17	3.53	3.1	3.2	4	0.4	0.08
KX-0329235	32.92	3.53	3.1	3.2	4	0.4	0.08
KX-0376935	37.69	3.53	3.1	3.2	4	0.4	0.08
KX-0186435	18.64	3.53	3.1	3.2	4	0.4	0.08
KX-0265835	26.58	3.53	3.1	3.2	4	0.4	0.08
KX-0297535	29.75	3.53	3.1	3.2	4	0.4	0.08
KX-0345235	34.52	3.53	3.1	3.2	4	0.4	0.08
KX-2789935	278.99	3.53	3.1	3.2	4	0.4	0.08
KX-0406553	40.65	5.33	4.75	4.9	6	0.4	0.1
KX-0501653	50.16	5.33	4.75	4.9	6	0.4	0.1
KX-0597053	59.7	5.33	4.75	4.9	6	0.4	0.1
KX-0692253	69.22	5.33	4.75	4.9	6	0.4	0.1
KX-0755753	75.57	5.33	4.75	4.9	6	0.4	0.1
KX-0787453	78.74	5.33	4.75	4.9	6	0.4	0.1
KX-0914453	91.44	5.33	4.75	4.9	6	0.4	0.1
KX-1009753	100.97	5.33	4.75	4.9	6	0.4	0.1
KX-1104953	110.49	5.33	4.75	4.9	6	0.4	0.1
KX-1136753	113.67	5.33	4.75	4.9	6	0.4	0.1
KX-1200253	120.02	5.33	4.75	4.9	6	0.4	0.1
KX-0374753	37.47	5.33	4.75	4.9	6	0.4	0.1
KX-0533453	53.34	5.33	4.75	4.9	6	0.4	0.1
KX-1263769	126.37	6.99	6.2	6.4	8	0.6	0.1
KX-1359069	135.9	6.99	6.2	6.4	8	0.6	0.1
KX-1454269	145.42	6.99	6.2	6.4	8	0.6	0.1
KX-1581269	158.12	6.99	6.2	6.4	8	0.6	0.1



HYDRAULIC ROD SEALING ELEMENTS



Lined writing area consisting of 25 horizontal light gray lines.

KASTAS CODE	PRODUCT NAME	DRAWING	APPLICATION	MATERIAL	CODE	PRESSURE (max) bar	TEMPERATURE (max) °C	SLIDING SPEED (max) - m/sec	PAGE
K01	Rod Packing		Rod	NBR FABRIC NBR POM	NB9001 NB8008 PM9903	400	-30/+105	0.5	62
K04	Rod Packing		Rod	NBR FABRIC NBR POM	NB9001 NB8008 PM9903	400	-30/+105	0.5	66
K22	Rod Seal		Rod	NBR PU	NB9001 PU9201	150 400	-30/+105 -30/+100	0.5 0.5	68
K29	Buffer Seal		Rod	PU POM	PU9201 PM9901	400	-30/+100	0.5	74
K31	Heavy Duty Rod Seal		Rod	NBR PU POM	NB7001 PU9401 PM9901	630	-30/+100	0.5	76
K32	Rod Seal		Rod	PU POM	PU9401 PM9901	400	-30/+100	0.5	80
K33	Rod Seal		Rod	PU	PU9401	400	-30/+100	0.5	84
K34	Rod Seal		Rod	NBR FABRIC NBR TPE POM	NB8001 NB8008 TP5501 PM9901	700	-30/+105	0.5	90
K35	Rod Seal		Rod	NBR PTFE	NB7001 PT6003	400	-30/+105	5.0	92
K37	Rod Seal		Rod	NBR FABRIC NBR POM	NB8001 NB8008 PM9901	400	-30/+105	0.5	96
K38	Rod Seal		Rod	PU	PU9401	400	-30/+100	0.5	102
K96	Rod Seal		Rod	NBR	NB9001	150	-30/+105	0.5	106
K701	Spring Loaded Rod Seal		Rod	PTFE V-SPRING	PT6002 CN9902	350	-150/+250	15.0	108



K01 is a seven piece single acting sealing set which consists of one reinforced cotton fabric backup ring, one thermoplastic header ring, three reinforced cotton fabric middle rings, and two elastomeric nitrile rubber middle rings.

PRODUCT ADVANTAGES

- Adjustable seal housing height due to the reason of being used in open grooves.
- Functions even with poor surfaces
- Robust seal
- Easy installation and removal
- Long service life
- Able to work until the maintenance of continuity systems because of the adjustable housing
- Very good sealing performance both in high and low pressures

APPLICATION

Used especially in hard working conditions such as iron and steel industry, mining equipment, marine hydraulics, scrap cutters and special cylinders where the actual conditions are difficult to predict.

MATERIAL		CODE
NBR	90 SHORE A	NB9001
COTTON FABRIC NBR		NB8008
POM		PM9903

OPERATING CONDITIONS			
MEDIA	Mineral oils (DIN 51524)	HFA and HFB	HFC
TEMPERATURE	-30°C +105°C	+5°C +60°C	-30°C +60°C
PRESSURE	≤400 Bar	≤400 Bar	≤400 Bar
SPEED	≤0.5 m/sec	≤0.5 m/sec	≤0.5 m/sec

Note: The above data are maximum values and cannot be used at the same time.

SURFACE ROUGHNESS		Ra	Rmax
Sliding Surface	Ød	≤0.4 µm	≤3.2 µm
Groove Base	ØD	≤1.6 µm	≤6.3 µm
Groove Flanks	B	≤3.2 µm	≤16 µm

Note: It is recommended to have 50% to 90% of the working surface material contact area value.

INSTALLATION

Being assembled in adjustable housing, the groove housing should have an adjustability of 7.5% of the seal height. If there is a requirement of being used in closed housings, individual parts should be cut with 45° angle and staggered by 75° angle at installation. When strongly squeezed, the flexibility of the sealing set may be substantially reduced. This could cause excessive friction force, high wear and vibrated operating under low pressures. It is very important that the assembly tools must be of soft material and have no sharp edges. Before installation all individual parts of the seal must be oiled with system oil.

NOTES

For special applications that require high temperatures, our seal set can be manufactured in the following configuration, reinforced cotton fabric with FKM for header and middle rings and special mixture of PTFE backup ring. Permissible sealing gap S value should not be above 0.15 mm. For inner diameters above 200 mm, all the middle rings are produced from reinforced cotton fabric with NBR material. Additional middle rings can be used depending on the application.

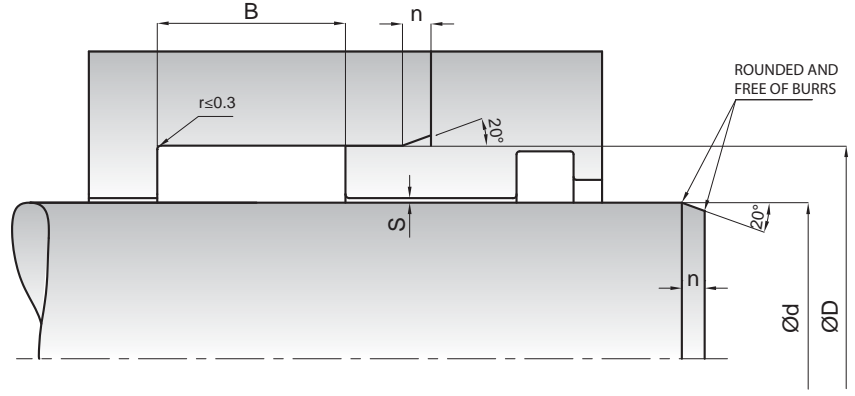
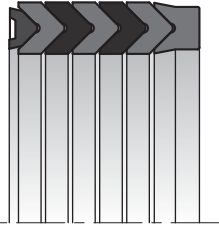

KASTAŞ NO	d (f8)	D (H9)	B (-0/+0.2)	n
K01-008	8	18	18.5	4
K01-010	10	20	18.5	4
K01-012	12	22	18.5	4
K01-013	13.5	25	16.5	4
K01-014	14	24	18.5	4
K01-015	15	25	18.5	4
K01-015/1	15	32	25	6
K01-016	16	26	18.5	4
K01-018	18	28	18.5	4
K01-018/1	18	32	23.5	4
K01-020	20	30	18.5	4
K01-020/1	20	32	22.5	4
K01-022	22	32	18.5	4
K01-022/1	22	34	22.5	4
K01-025	25	37	22.5	4
K01-025/1	25	40	22.5	6
K01-028	28	40	22.5	4
K01-028/1	28	43	22.5	6
K01-030	30	42	22.5	4
K01-030/1	30	45	22.5	6
K01-030/2	30	50	37	6
K01-032	32	44	22.5	4
K01-032/1	32	47	22.5	6
K01-035	35	47	22.5	4
K01-035/1	35	50	22.5	6
K01-036	36	48	22.5	4
K01-036/1	36	51	22.5	6
K01-040	40	52	22.5	4
K01-040/1	40	55	22.5	6
K01-040/3	40	56	22.5	6
K01-042	42	54	22.5	4
K01-042/1	42	57	22.5	6
K01-045	45	60	22.5	6
K01-045/1	45	65	22.5	6
K01-045/3	45	62	26	6
K01-047	47	65	33	6
K01-048	48	63	22.5	6
K01-050	50	65	22.5	6
K01-050/1	50	70	30	6
K01-055	55	70	22.5	6
K01-055/1	55	75	30	6
K01-055/2	55	67	24	4
K01-056	56	71	22.5	6
K01-056/1	56	76	37	6
K01-056/2	56	72	49	6
K01-060	60	75	22.5	6
K01-060/1	60	80	37	6
K01-060/3	60	85	37	8
K01-063	63	78	22.5	6

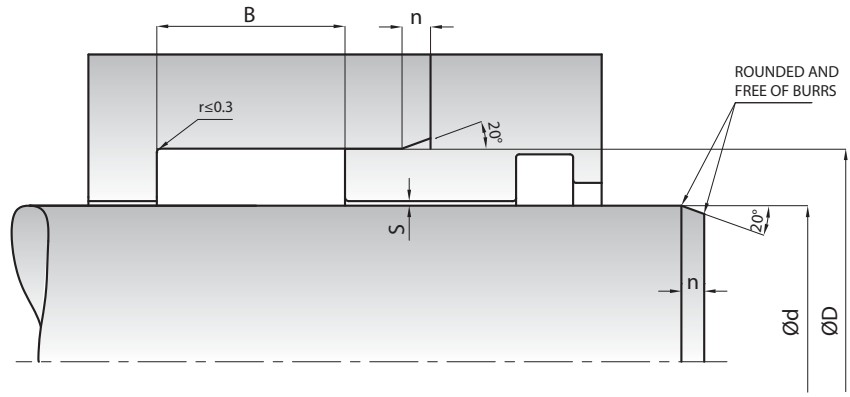
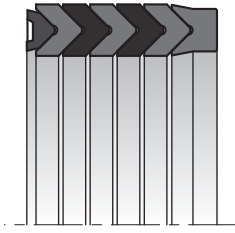

KASTAŞ NO	d (f8)	D (H9)	B (-0/+0.2)	n
K01-063/1	63	83	37	6
K01-063/2	63.5	78	40	4
K01-065	65	80	22.5	6
K01-065/1	65	85	40	6
K01-070	70	85	22.5	6
K01-070/1	70	90	40	6
K01-075	75	90	22.5	6
K01-075/1	75	95	40	6
K01-075/2	75	87	25	4
K01-075/3	75	100	34	8
K01-080	80	95	22.5	6
K01-080/1	80	100	40	6
K01-085	85	100	22.5	6
K01-085/1	85	105	40	6
K01-090	90	105	22.5	6
K01-090/1	90	110	40	6
K01-090/2	90	110	26	6
K01-095	95	120	50	8
K01-100	100	115	30	6
K01-100/1	100	120	40	6
K01-105	105	120	30	6
K01-105/1	105	125	40	6
K01-105/2	105	130	40	8
K01-110	110	125	30	6
K01-110/1	110	130	40	6
K01-115	115	130	30	6
K01-115/1	115	140	46	6
K01-115/2	115	140	30	8
K01-120	120	140	49	6
K01-120/1	120	145	46	8
K01-125	125	140	34	6
K01-125/1	125	150	46	8
K01-130	130	155	42.5	8
K01-135	135	160	55	8
K01-135/1	135	160	40	8
K01-140	140	155	34	6
K01-140/1	140	165	46	8
K01-150	150	170	40	6
K01-150/1	150	180	60	8
K01-160	160	180	40	6
K01-160/1	160	190	60	8
K01-165	165	195	50.5	8
K01-180	180	200	40	6
K01-180/1	180	210	60	8
K01-190	190	220	42	8
K01-200	200	220	40	6
K01-200/1	200	230	60	8
K01-210	210	240	50	8
K01-215	215	245	41	8



K04 is a seven piece single acting sealing set which consists of one reinforced cotton fabric backup ring, one thermoplastic header ring, three reinforced cotton fabric middle rings, and two elastomeric nitrile rubber middle rings.

PRODUCT ADVANTAGES

- Adjustable seal housing height due to the reason of being used in open grooves.
- Functions even with poor surfaces
- Robust seal
- Easy installation and removal
- Long service life
- Able to work until the maintenance of continuity systems because of the adjustable housing
- Very good sealing performance both in high and low pressures

APPLICATION

Especially used in hard working conditions such as iron and steel industry, mining equipment, marine hydraulics, scrap cutters and special cylinders where the actual conditions are difficult to predict.

MATERIAL		CODE
NBR	90 SHORE A	NB9001
COTTON FABRIC NBR		NB8008
POM		PM9903

OPERATING CONDITIONS			
MEDIA	Mineral oils (DIN 51524)	HFA and HFB	HFC
TEMPERATURE	-30°C +105°C	+5°C +60°C	-30°C +60°C
PRESSURE	≤400 Bar	≤400 Bar	≤400 Bar
SPEED	≤0.5 m/sec	≤0.5 m/sec	≤0.5 m/sec

Note: The above data are maximum values and cannot be used at the same time.

SURFACE ROUGHNESS		Ra	Rmax
Sliding Surface	Ød	≤0.4 µm	≤3.2 µm
Groove Base	ØD	≤1.6 µm	≤6.3 µm
Groove Flanks	B	≤3.2 µm	≤16 µm

Note: It is recommended to have 50% to 90% of the working surface material contact area value

INSTALLATION

Being assembled in adjustable housings, the groove housing should have an adjustability of 7.5% of the seal height. If there is a requirement of being used in closed housings, individual parts should be cut with 45° angle and staggered by 75° angle at installation. When strongly squeezed, the flexibility of the sealing set may be substantially reduced. This could cause excessive friction force, high wear and vibrated operating under low pressures. It is very important that the assembly tools must be of soft material and have no sharp edges. Before installation all individual parts of the seal must be oiled with system oil.

NOTES

For special applications that require high temperatures, our seal can be manufactured in the following configuration, reinforced cotton fabric with FKM for header and middle rings and special mixture of PTFE backup ring. Permissible sealing gap S value should not be above 0.15 mm. For inner diameters above 200 mm, all the middle rings are produced from reinforced cotton fabric with NBR material. Additional middle rings can be used depending on the application.

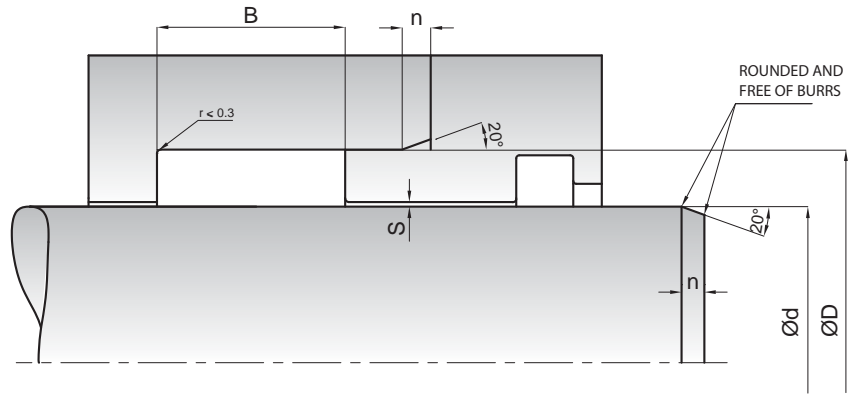
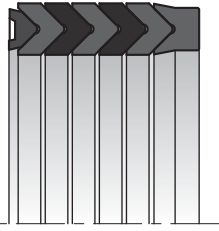

KASTAŞ NO	d (f8)	D (H9)	B (-0/+0.2)	n
K04-012	12.75	25.4	19.05	4
K04-019	19.05	28.5	17.46	4
K04-020	20.62	33.32	33.32	4
K04-022	22.22	34.92	19.05	4
K04-031	31.75	44.45	25.4	4
K04-038	38.1	50.8	25.4	4
K04-038/1	38.1	53.98	25.4	4
K04-044	44.45	57.15	25.4	4
K04-044/1	44.45	63.5	38.1	6
K04-044/2	44.45	69.85	50.8	8
K04-050	50.8	63.5	25.4	4
K04-050/1	50.8	65	25.4	4
K04-050/2	50.8	66.67	25.4	6
K04-050/3	50.8	69.85	25.4	6
K04-053	53.98	69.85	28.5	6
K04-057	57.16	76.2	25.4	6
K04-063/1	63.5	78	41	4
K04-063	63.5	76.2	28.5	4
K04-063/2	63.5	79.37	28.5	6
K04-063/3	63.5	82.55	28.5	6
K04-069	69.85	88.9	31.75	6
K04-076	76.2	88.9	25.4	4
K04-076/1	76.2	95.25	31.75	6
K04-076/2	76.2	101.6	38.1	8
K04-082	82.55	101.6	31.75	6
K04-088	88.9	104.8	28.5	6
K04-088/1	88.9	107.95	30.16	6
K04-088/2	88.9	114.3	38.1	8
K04-095	95.25	114.3	30.16	6
K04-101	101.6	127	38.1	8
K04-107	107.95	127	31.75	6
K04-107/1	107.95	130.18	38.1	6
K04-114	114.3	133.36	31.75	6
K04-114/1	114.3	139.7	38.1	8
K04-127	127	158.75	60	8
K04-209	209.55	228.6	38.1	6



K22 is a single acting rod seal designed to have inner lip shorter than the outer lip in order to be used for rod applications.

PRODUCT ADVANTAGES

- Superior static and dynamic sealing effect
- Wide range of dimensions
- Easy assembly into closed grooves
- Simple groove design
- Economical sealing solution

APPLICATION

Construction machinery, fork-lift trucks, injection moulding machines, agricultural machinery, loading platforms and standard cylinders.

MATERIAL		CODE
NBR	90 SHORE A	NB9001
PU	92 SHORE A	PU9201

OPERATING CONDITIONS			
NBR			
MEDIA	Mineral oils (DIN 51524)	HFA and HFB	HFC
TEMPERATURE	-30°C +105°C	+5°C +60°C	-30°C +60°C
PRESSURE	≤150 Bar	≤150 Bar	≤150 Bar
SPEED	≤0.5 m/sec	≤0.5 m/sec	≤0.5 m/sec

PU			
MEDIA	Mineral oils (DIN 51524)	HFA and HFB	HFC
TEMPERATURE	-30°C +100°C	+5°C +50°C	-30°C +40°C
PRESSURE	≤400 Bar	≤400 Bar	≤400 Bar
SPEED	≤0.5 m/sec	≤0.5 m/sec	≤0.5 m/sec

Note: The above data are maximum values and cannot be used at the same time.

SURFACE ROUGHNESS		Ra	Rmax
Sliding Surface	Ød	≤0.4 µm	≤3.2 µm
Groove Base	ØD	≤1.6 µm	≤10 µm
Groove Flanks	B	≤3.2 µm	≤16 µm

Note: It is recommended to have 50% to 90% of the working surface material contact area value.

INSTALLATION

Easily assembled into closed grooves according to the minimum diameter values that are given in the below table. Open grooves or special assembly tools should be used for the values that are outside this table. It is very important that the assembly tools must be of soft material and have no sharp edges. Before installation the rod seal must be oiled with system oil.

MINIMUM DIAMETER VALUES FOR CLOSED TYPE OF GROOVES							
(D-d)/2 (mm)	4	5	6	7.7	10	12.5	15
d min (mm)	25	30	40	50	80	100	105

NOTES

For special applications that require high temperatures, K22 can be produced in FKM material. The permissible sealing gap values of K22 is given below.

PERMISSIBLE SEALING GAP			
NBR		Smax (mm)	
t=(D-d)/2 (mm)	50 Bar	100 Bar	150 Bar
t≤5	0.40	0.20	0.10
t>5	0.45	0.25	0.15

PU		Smax (mm)	
t=(D-d)/2 (mm)	150 Bar	250 Bar	400 Bar
t≤5	0.30	0.20	0.15
t>5	0.35	0.25	0.20

Note: The largest sealing gap value occurring on the non-pressurized side of the seal does have a vital importance for the function of the seal and in this respect it is quite important to use the S value lower than the above indicated numbers.

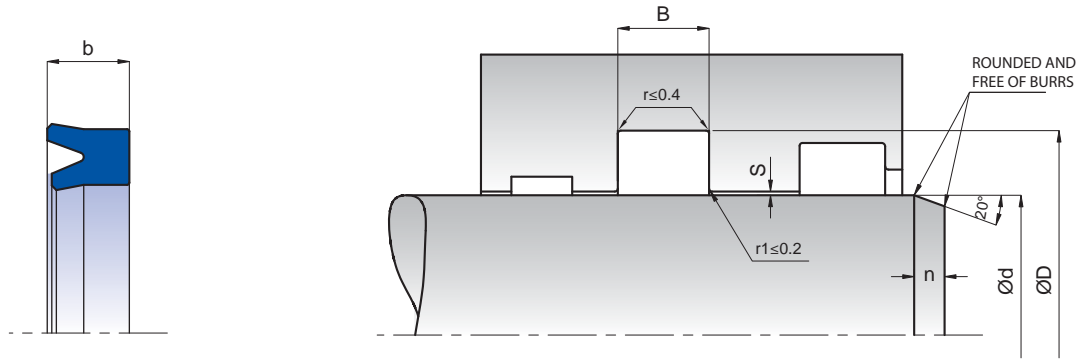

KASTAŞ NO	NBR	PU	d (f8)	D (H11)	b	B (-0/+0.2)	n
K22-002/1	NBR		2	4.5	1.7	2.2	2
K22-002/2	NBR		2	5.5	2.6	3.1	2
K22-002	NBR		2.5	5	1.7	2.2	2
K22-003/2	NBR		3	6	2.5	3	2
K22-003/1	NBR		3	6.5	3	3.5	2
K22-003	NBR		3	7	3	3.5	2
K22-003/3	NBR		3.17	8.76	3.96	4.46	3
K22-004/1	NBR		4	8	3	3.5	2
K22-004/3	NBR		4	9	3.5	4	2.5
K22-004/5	NBR		4	10	4.2	4.7	3
K22-004/2	NBR		4	12	4.5	5	4
K22-004/4	NBR		4.76	11.11	3.96	4.46	3
K22-005	NBR		5	12	4.5	5	3.5
K22-006/1	NBR	PU	6	10	3	3.5	2
K22-006/3	NBR	PU	6	12	4	4.5	3
K22-006/4		PU	6	13	5	6	3.5
K22-006	NBR		6	13	5.5	6.5	3.5
K22-006/5	NBR	PU	6	14	5.8	6.8	4
K22-006/2	NBR		6.35	12.76	3.96	4.46	3
K22-008	NBR	PU	8	14	4	4.5	3
K22-008/2	NBR		8	14	4.5	5	3
K22-008/4	NBR		8	16	5.5	6.5	4
K22-008/1	NBR		8	16	6	7	4
K22-009/1	NBR		9	15	9	10	3
K22-009/2	NBR		9.52	16.5	3.96	4.46	3.5
K22-010/7	NBR	PU	10	13.6	2.3	2.8	2
K22-010/4	NBR		10	14	2	2.5	2
K22-010/2	NBR	PU	10	14	4	4.5	2
K22-010/1	NBR	PU	10	16	4.5	5	3
K22-010/3	NBR		10	16	6	7	3
K22-010	NBR	PU	10	18	5.5	6.5	4
K22-010/6	NBR	PU	10	20	4.5	5	4.5
K22-010/5	NBR		10	20	6.5	7.5	4.5
K22-011	NBR	PU	11.11	19.05	3.96	4.46	4
K22-012/6	NBR	PU	12	16	3	3.5	2
K22-012/2	NBR	PU	12	17	3.7	4.2	2.5
K22-012/4	NBR		12	18	4.5	5	3
K22-012/1	NBR	PU	12	20	5.5	6.5	4
K22-012/3	NBR	PU	12	22	5	6	4.5
K22-012/5	NBR	PU	12	22	7.5	8.5	4.5
K22-012	NBR	PU	12	22	8	9	4.5
K22-013/2	NBR	PU	13	21.43	4.76	5.26	4
K22-013/1	NBR	PU	13	23	8	9	4.5
K22-014	NBR	PU	14	22	5.5	6.5	4
K22-014/1	NBR	PU	14.28	20.63	4.76	5.26	3
K22-015	NBR	PU	15	23	6	7	4
K22-015/1	NBR	PU	15.87	22.22	4.76	5.26	3
K22-016	NBR	PU	16	20.5	5	6	2.5
K22-016/6	NBR		16	22	4	4.5	3

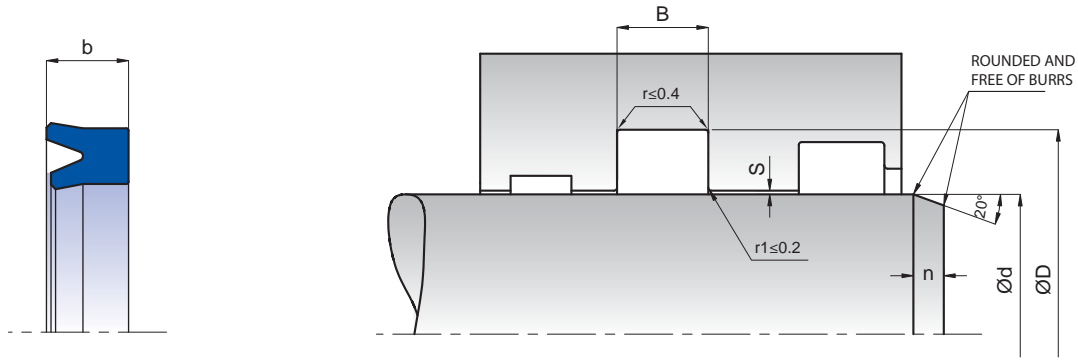

KASTAŞ NO	NBR	PU	d (f8)	D (H11)	b	B (-0/+0.2)	n
K22-016/1	NBR		16	22	4.5	5	3
K22-016/10	NBR	PU	16	22	5	6	3
K22-016/5	NBR	PU	16	23	5.5	6.5	3.5
K22-016/9	NBR	PU	16	24	5	6	4
K22-016/3	NBR	PU	16	24	5.5	6.5	4
K22-016/4	NBR	PU	16	24	6.5	7.5	4
K22-016/8	NBR	PU	16	26	5	6	4.5
K22-016/2	NBR	PU	16	26	7	8	4.5
K22-016/7	NBR		16	26	7.5	8.5	4.5
K22-017/1	NBR		17.46	23.81	4.76	5.26	3
K22-018/4	NBR		18	22	3	3.5	2
K22-018	NBR	PU	18	24	5	6	3
K22-018/5	NBR		18	25	4.5	5	3.5
K22-018/1	NBR	PU	18	25	5	6	3.5
K22-018/2	NBR	PU	18	25	5.5	6.5	3.5
K22-018/3	NBR	PU	18	28	7	8	4.5
K22-019	NBR	PU	19.05	25.4	4.76	5.26	3
K22-020/6	NBR	PU	20	26	3.5	4	3
K22-020/4	NBR	PU	20	28	5.5	6.5	4
K22-020/12	NBR	PU	20	28.57	4.76	5.26	4
K22-020	NBR	PU	20	30	6	7	4.5
K22-020/8	NBR	PU	20	30	7	8	4.5
K22-020/9	NBR	PU	20	30	7.5	8.5	4.5
K22-020/7	NBR	PU	20	30	8	9	4.5
K22-020/2	NBR	PU	20	30	10	11	4.5
K22-020/10	NBR	PU	20	32	6	7	5
K22-020/11	NBR		20	32	7	8	5
K22-020/3	NBR	PU	20	32	7.5	8.5	5
K22-022/6	NBR	PU	22	29	5	6	3.5
K22-022/3	NBR	PU	22	30	5.5	6.5	4
K22-022/2	NBR	PU	22	30	7	8	4
K22-022/1	NBR	PU	22	30	8	9	4
K22-022	NBR	PU	22	32	6	7	4.5
K22-022/7	NBR	PU	22.22	31.75	4.76	5.26	4.5
K22-022/4	NBR	PU	22.22	31.75	6.35	7.35	4.5
K22-023	NBR	PU	23	31	5.5	6.5	4
K22-023/1	NBR	PU	23.81	36.51	6.35	7.35	5
K22-025/7	NBR	PU	25	32	6	7	3.5
K22-025/10	NBR	PU	25	33	5.5	6.5	4
K22-025/4	NBR	PU	25	33	10	11	4
K22-025	NBR	PU	25	35	6	7	4.5
K22-025/3	NBR		25	35	7	8	4.5
K22-025/9	NBR	PU	25	35	7.5	8.5	4.5
K22-025/1	NBR	PU	25	35	8	9	4.5
K22-025/8	NBR	PU	25	35	10	11	4.5
K22-025/5	NBR	PU	25	37	6	7	5
K22-025/6	NBR	PU	25	40	10	11	5.5
K22-028/10	NBR	PU	28	35	7	8	3.5
K22-028/7	NBR		28	36	5	6	4

KASTAŞ NO	NBR	PU	d (f8)	D (H11)	b	B (-0/+0.2)	n
K22-028/4	NBR	PU	28	36	5.5	6.5	4
K22-028/9		PU	28	36	5.7	6.7	4
K22-028/11		PU	28	36	8	9	4
K22-028	NBR	PU	28	38	6	7	4.5
K22-028/6	NBR	PU	28	38	7	8	4.5
K22-028/8	NBR	PU	28	38	8	9	4.5
K22-028/2	NBR	PU	28	38	10	11	4.5
K22-030/5	NBR	PU	30	38	5.5	6.5	4
K22-030/6		PU	30	38	5.7	6.7	4
K22-030/4	NBR	PU	30	38	6	7	4
K22-030/3	NBR	PU	30	38	6.3	7.3	4
K22-030/8	NBR	PU	30	38	8	9	4
K22-030/1	NBR	PU	30	40	6	7	4.5
K22-030/2	NBR	PU	30	40	7	8	4.5
K22-030	NBR	PU	30	40	8	9	4.5
K22-030/7	NBR	PU	30	42	8.5	9.5	5
K22-030/9	NBR	PU	30.16	38.1	6.35	7.35	4
K22-031	NBR	PU	31.75	44.45	6.35	7.35	5
K22-032	NBR	PU	32	42	7	8	4.5
K22-032/1	NBR	PU	32	48	8	9	6
K22-033		PU	33	40	5.5	6.5	3.5
K22-033/1	NBR	PU	33.33	40.64	4.76	5.26	3.5
K22-034	NBR	PU	34	44	7	8	4.5
K22-034/1	NBR	PU	34.92	50.8	7.93	8.93	6
K22-035/6	NBR	PU	35	43	6	7	4
K22-035/7	NBR	PU	35	43	8	9	4
K22-035/4	NBR	PU	35	45	6	7	4.5
K22-035/1	NBR	PU	35	45	7	8	4.5
K22-035	NBR	PU	35	45	8	9	4.5
K22-035/5	NBR	PU	35	45	10	11	4.5
K22-035/3	NBR	PU	35	50	8	9	5.5
K22-036	NBR	PU	36	46	8	9	4.5
K22-036/2	NBR	PU	36	46	10	11	4.5
K22-038	NBR	PU	38.1	50.8	9.52	10.52	5
K22-040/7	NBR	PU	40	48	5.4	6.4	4
K22-040/9	NBR	PU	40	48	5.8	6.8	4
K22-040/6	NBR	PU	40	48	8	9	4
K22-040/2	NBR	PU	40	50	7	8	4.5
K22-040/3	NBR	PU	40	50	8	9	4.5
K22-040	NBR	PU	40	50	10	11	4.5
K22-040/4	NBR		40	55	10	11	5.5
K22-041	NBR	PU	41.27	50.8	5.56	6.56	4.5
K22-042	NBR	PU	42	52	7	8	4.5
K22-042/1	NBR	PU	42.86	53.97	9.52	10.52	5
K22-044	NBR	PU	44.45	57.15	7.93	8.93	5
K22-045/3	NBR	PU	45	55	7	8	4.5
K22-045	NBR	PU	45	55	10	11	4.5
K22-045/4	NBR	PU	45	60	7	8	5.5
K22-045/2	NBR	PU	45	61	12	13	6
K22-045/5	NBR	PU	45	65	10	11	6
K22-050/5	NBR	PU	50	60	6	7	4.5
K22-050/4	NBR	PU	50	60	7	8	4.5
K22-050	NBR	PU	50	60	10	11	4.5
K22-050/2	NBR	PU	50	60.33	9.52	10.52	4.5
K22-050/7		PU	50	62	8	9	5
K22-050/6	NBR		50	62	10	11	5
K22-050/3		PU	50	65	10	11	5.5
K22-052	NBR	PU	52	62	10	11	4.5
K22-052/1	NBR	PU	52	69	9	10	6
K22-054	NBR		54	64	7	8	4.5
K22-055/2		PU	55	64	7.3	8.3	4
K22-055/3	NBR	PU	55	65	7.3	8.3	4.5
K22-055	NBR	PU	55	65	10	11	4.5
K22-055/1	NBR		55	70	10	11	5.5
K22-056/2	NBR	PU	56	66	10	11	4.5

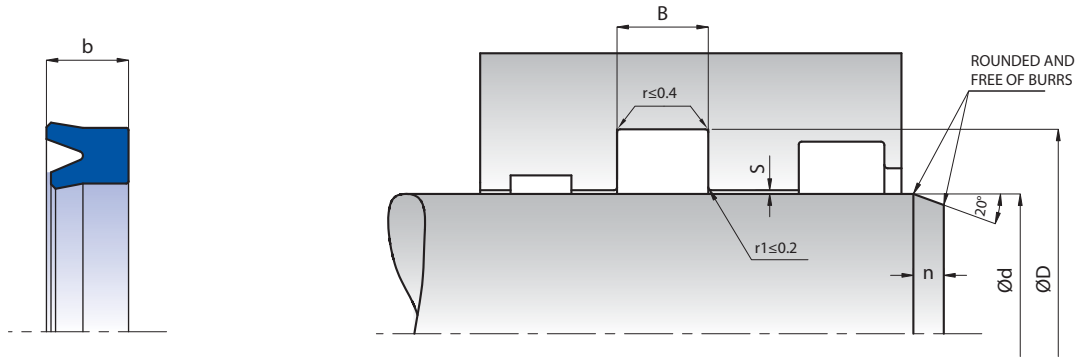

KASTAŞ NO	NBR	PU	d (f8)	D (H11)	b	B (-0/+0.2)	n
K22-056	NBR	PU	56	68	8.5	9.5	5
K22-060/3	NBR	PU	60	70	8.5	9.5	4.5
K22-060	NBR	PU	60	70	10	11	4.5
K22-060/5	NBR	PU	60	70	12	13	4.5
K22-060/4	NBR	PU	60	72	8.5	9.5	5
K22-060/1	NBR	PU	60	74	8	9	5.5
K22-060/2	NBR	PU	60	75	12	13	5.5
K22-063	NBR	PU	63	73	6.5	7.5	4.5
K22-063/3		PU	63	73	12	13	4.5
K22-063/2	NBR	PU	63	75	8.5	9.5	5
K22-063/4		PU	63	78	10	11	5.5
K22-063/1		PU	63.5	76.2	9.52	10.52	6
K22-065	NBR	PU	65	75	10	11	4.5
K22-068	NBR		68	80	8.5	9.5	5
K22-069/1		PU	69.85	85	13	14	5.5
K22-070	NBR	PU	70	80	12	13	4.5
K22-070/4	NBR		70	82	8.5	9.5	5
K22-070/1	NBR	PU	70	85	10	11	5.5
K22-070/5		PU	70	90	13.5	14.5	6
K22-075	NBR	PU	75	85	12	13	4.5
K22-075/1		PU	75	95	12	13	6
K22-080	NBR	PU	80	90	12	13	4.5
K22-080/3	NBR		80	92	7.5	8.5	5
K22-080/2	NBR		80	92	8.5	9.5	5
K22-080/1	NBR		80	92	9.5	10.5	5
K22-082		PU	82.5	95.25	9.52	10.52	6
K22-085/1	NBR	PU	85	95	7	8	4.5
K22-085	NBR	PU	85	95	12	13	4.5
K22-090	NBR	PU	90	100	12	13	4.5
K22-090/1	NBR		90	102	8.5	9.5	5
K22-090/2		PU	90	110	11.5	12.5	6
K22-095	NBR	PU	95	105	12	13	4.5
K22-095/1		PU	95	110	12	13	5.5
K22-100	NBR		100	110	14	15	4.5
K22-100/3	NBR		100	115	10	11	5.5
K22-100/2		PU	100	115	12	13	5.5
K22-100/4		PU	100	120	13.5	14.5	6
K22-105	NBR	PU	105	120	12	13	5.5
K22-106		PU	106	120	10	11	5.5
K22-110	NBR		110	130	14	15	6
K22-115	NBR	PU	115	125	12	13	4.5
K22-120	NBR	PU	120	135	9.5	10.5	5.5
K22-120/2		PU	120	140	14.6	15.6	6
K22-125		PU	125	135	13.5	14.5	4.5
K22-125/1		PU	125	145	12	13	6
K22-125/2	NBR		125	145	14	15	6
K22-130		PU	130	140	13.5	14.5	4.5
K22-132		PU	132	142	6	7	4.5
K22-135	NBR	PU	135	145	12	13	4.5



K29 is a two piece single acting buffer seal which consists of one special designed elastomeric sealing element to evacuate the back pressure and one thermoplastic back-up ring.

PRODUCT ADVANTAGES

- No pressure build up between the primary and secondary seal
- Highly wear resistant
- Low friction
- Low axial housing heights
- Good protection to the secondary seal with pressure peaks

APPLICATION

Construction machinery, fork-lift trucks, injection moulding machines, agricultural machinery, cranes, earth moving equipment and standard cylinders.

MATERIAL	CODE	
PU	92 SHORE A	PU9201
POM		PM9901

OPERATING CONDITIONS			
MEDIA	Mineral oil (DIN 51524)	HFA and HFB	HFC
TEMPERATURE	-30°C +100°C	+5°C +50°C	-30°C +40°C
PRESSURE	≤400 Bar	≤400 Bar	≤400 Bar
SPEED	≤0.5 m/sec	≤0.5 m/sec	≤0.5 m/sec

Note: The above data are maximum values and cannot be used at the same time.

SURFACE ROUGHNESS		Ra	Rmax
Sliding Surface	∅d	≤0.4 μm	≤3.2 μm
Groove Base	∅D	≤1.6 μm	≤6.3 μm
Groove Flanks	B	≤3.2 μm	≤16 μm

Note: It is recommended to have 50% to 90% of the working surface material contact area value.

INSTALLATION

Easily assembled into closed grooves. It is very important that the assembly tools must be of soft material and have no sharp edges. Before installation the sealing element must be oiled with system oil.

NOTES

K29 buffer seal is always used in a sealing system in combination with u-ring (K22, K33, etc) as they are not designed as being the main sealing element. K29 reduces the pressure peaks on itself in order to save the main sealing element with pressure fluctuations. The permissible sealing gap values of K29 seal is given below.

PERMISSIBLE SEALING GAP			
B (mm)	Smax (mm)		
	150 bar	250 bar	400 bar
≤6.3	0.6	0.5	0.4

Note: The largest sealing gap value occurring on the non-pressurized side of the seal does have a vital importance for the function of the seal and in this respect it is quite important to use the S value lower than the above indicated numbers.



K31 is a three piece single acting sealing set which consist of one elastomeric main sealing element with additional sealing lip, one special profile elastomer nitrile rubber that goes into the main sealing component and one thermoplastic back-up ring.

PRODUCT ADVANTAGES

- Able to work in high pressures
- Superior sealing effect in low pressures
- Easy assembly into closed grooves
- Superior sealing effect with the secondary lip
- Secondary sealing lip provides extra protection against the ingress of dirt particles.
- Highly wear resistant
- Improved sealing gap due to the active back-up ring

APPLICATION

Mining equipment, iron and steel industry, metal injection machines, scrap cutters, marine hydraulics, cranes and mobile hydraulics.

MATERIAL		CODE
NBR	70 SHORE A	NB7001
PU	94 SHORE A	PU9401
POM		PM9901

OPERATING CONDITIONS

MEDIA	Mineral oils (DIN 51524)	HFA and HFB	HFC
TEMPERATURE	-30°C +100°C	+5°C +50°C	-30°C +40°C
PRESSURE	≤630 Bar	≤630 Bar	≤630 Bar
SPEED	≤0.5 m/sec	≤0.5 m/sec	≤0.5 m/sec

Note: The above data are maximum values and cannot be used at the same time.

SURFACE ROUGHNESS

		Ra	Rmax
Sliding Surface	Ød	≤0.4 µm	≤3.2 µm
Groove Base	ØD	≤1.6 µm	≤10 µm
Groove Flanks	B	≤3.2 µm	≤16 µm

Note: It is recommended to have 50% to 90% of the working surface material contact area value

INSTALLATION

Easily assembled into closed grooves according to the minimum diameter values that are given in the below table. Open grooves or special assembly tools should be used for the values that are outside this table. It is very important that the assembly tools must be of soft material and have no sharp edges. Before installation the rod seal must be oiled with system oil.

MINIMUM DIAMETER VALUES FOR CLOSED TYPE OF GROOVES

(D-d)/2 (mm)	≤7.5	10	12.5	15
d min (mm)	50	80	100	105

NOTES

K31 can be used in all type of cylinders safely due to the reason of perfect adaptation to the pressure changes.

PERMISSIBLE SEALING GAP

Pressure (Bar)	Smax (mm)
150	1.0
250	0.8
400	0.6
630	0.4

Note: The largest sealing gap value occurring on the non-pressurized side of the seal does have a vital importance for the function of the seal and in this respect it is quite important to use the S value lower than the above indicated numbers.

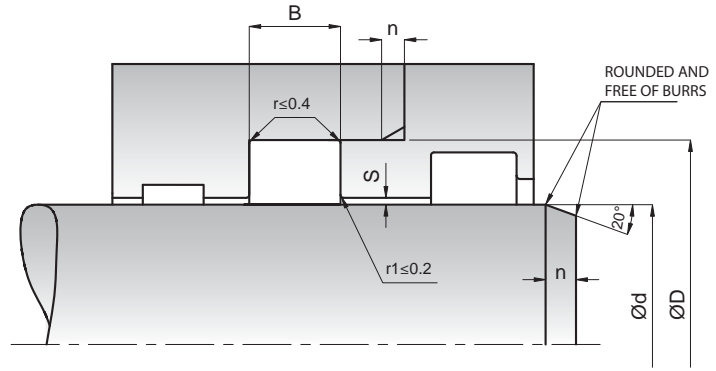
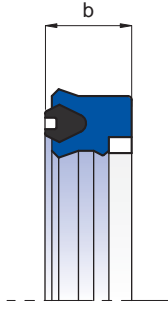

KASTAŞ NO	d (f8)	D(H11)	B(-0/+0,2)	b	n
K31-025 PU	25	35	8.3	7.3	4
K31-030 PU	30	40	11	10	4
K31-031 PU	31.75	38.1	7.35	6.35	3
K31-035 PU	35	50	10.5	9.5	5
K31-038 PU	38.1	47.625	7.35	6.35	5
K31-040 PU	40	55	10.5	9.5	5
K31-040/1 PU	40	50	8.3	7.3	4
K31-040/2 PU	40	55	12.4	11.4	5
K31-044 PU	44.45	57.15	10.52	9.52	4.5
K31-045 PU	45	60	12.4	11.4	5
K31-050 PU	50	65	12.4	11.4	5
K31-050/3 PU	50	60	8.3	7.3	4
K31-050/1 PU	50.8	60.32	10.52	9.52	4
K31-050/2 PU	50.8	63.5	10.52	9.52	4.5
K31-055 PU	55	70	12.4	11.4	5
K31-055/1 PU	55	68	14	13	4.5
K31-057 PU	57.15	69.85	10.52	9.52	4.5
K31-060 PU	60	75	12.4	11.4	5
K31-060/1 PU	60	73	14	13	4.5
K31-063 PU	63.5	76.2	10.52	9.52	4.5
K31-065 PU	65	78	11	10	4.5
K31-065/1 PU	65	80	10	9	5
K31-069 PU	69.85	82.55	10.52	9.52	4.5
K31-070 PU	70	85	12.4	11.4	5
K31-070/1 PU	70	83	11	10	4.5
K31-070/2 PU	70	85	10	9	5
K31-070/3 PU	70	80	13	12	4
K31-070/4 PU	70	85	11	10	5
K31-075 PU	75	88	11	10	4.5
K31-075/1 PU	75	90	10	9	5
K31-076/2 PU	76.2	88.9	10.52	9.52	4.5
K31-076 PU	76.2	92.7	13.7	12.7	5.5
K31-080 PU	80	95	12.4	11.4	5
K31-080/1 PU	80	93	11	10	4.5
K31-080/2 PU	80	95	10	9	5
K31-082 PU	82.55	95.25	10.52	9.52	4.5
K31-085 PU	85	100	11	10	5
K31-085/1 PU	85	105	16	15	6
K31-088 PU	88.9	101.6	10.52	9.52	4.5
K31-088/1 PU	88.9	104.77	13.7	12.7	5.5
K31-090 PU	90	105	12.4	11.4	5
K31-090/1 PU	90	105	11	10	5
K31-090/2 PU	90	110	18	17	6
K31-090/4 PU	90	100	13	12	4
K31-090/3 PU	90	110	15.5	14.5	6
K31-095 PU	95	110	11	10	5
K31-095/1 PU	95	115	16	15	6
K31-100 PU	100	120	15.5	14.5	6
K31-100/1 PU	100	115	11	10	5

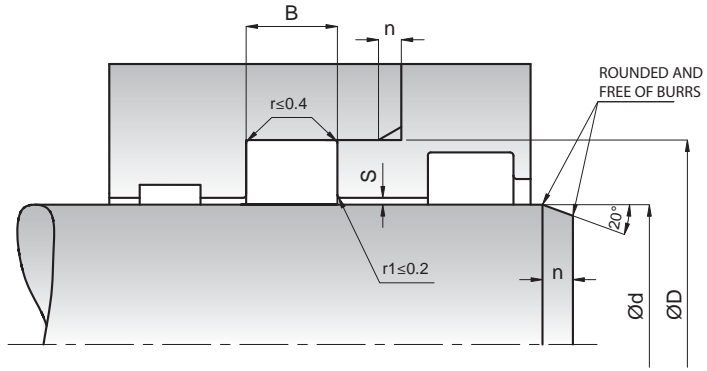
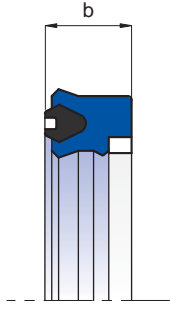

KASTAŞ NO	d (f8)	D(H11)	B(-0/+0,2)	b	n
K31-101 PU	101.6	114.3	15.28	14.28	4.5
K31-101/1PU	101.6	117.47	15.27	14.27	5.5
K31-105 PU	105	120	13	12	5
K31-110 PU	110	130	13	12	6
K31-110/1 PU	110	125	13	12	5
K31-110/2 PU	110	130	15.5	14.5	6
K31-114 PU	114.3	127	15.28	14.28	4.5
K31-114/1 PU	114.3	133.35	16.87	15.87	6
K31-115 PU	115	135	15.5	14.5	6
K31-120 PU	120	140	13	12	6
K31-125 PU	125	145	15.5	14.5	6
K31-127 PU	127	146.05	16.87	15.87	6
K31-130 PU	130	150	15.5	14.5	6
K31-139 PU	139.7	152.4	15.28	14.28	4.5
K31-140 PU	140	160	15.5	14.5	6
K31-150 PU	150	160	15.5	14.5	4
K31-150/1 PU	150	170	15.5	14.5	6
K31-152 PU	152	171	16.9	15.87	6



20 horizontal light gray lines for writing.



K32 is a two piece single acting rod seal which consists of one elastomeric sealing element specially designed with additional sealing lip and one thermoplastic back-up ring.

PRODUCT ADVANTAGES

- Superior sealing effect with the secondary lip
- High wear resistant
- Secondary sealing lip provides extra protection against the ingress of dirt particles.
- Improved sealing gap due to the active back-up ring
- Simple groove design

APPLICATION

Construction machinery, fork-lift trucks, injection moulding machines, agricultural machinery, mining equipment and standard cylinders.

MATERIAL		CODE
PU	94 SHORE A	PU9401
POM		PM9901

OPERATING CONDITIONS			
MEDIA	Mineral oils (DIN 51524)	HFA and HFB	HFC
TEMPERATURE	-30°C +100°C	+5°C +50°C	-30°C +40°C
PRESSURE	≤400 Bar	≤400 Bar	≤400 Bar
SPEED	≤0.5 m/sec	≤0.5 m/sec	≤0.5 m/sec

Note: The above data are maximum values and cannot be used at the same time.

SURFACE ROUGHNESS		Ra	Rmax
Sliding Surface	Ød	≤0.4 µm	≤3 µm
Groove Base	ØD	≤1.6 µm	≤10 µm
Groove Flanks	B	≤3.2 µm	≤16 µm

Note: It is recommended to have 50% to 90% of the working surface material contact area value.

INSTALLATION

Easily assembled into closed grooves according to the minimum diameter values that are given in the below table. Open grooves or special assembly tools should be used for the values that are outside this table. Before installation the sealing element must be oiled with system oil.

MINIMUM DIAMETER VALUES FOR CLOSED TYPE OF GROOVES							
(D-d)/2 (mm)	4	5	6	7.5	10	12.5	15
d min (mm)	25	30	40	50	80	100	105

NOTES

The permissible sealing gap values of K32 rod seal is given in the below table.

PERMISSIBLE SEALING GAP	
Pressure (Bar)	Smax (mm)
150	1.0
250	0.8
400	0.6

Note: The largest sealing gap value occurring on the non-pressurized side of the seal does have a vital importance for the function of the seal and in this respect it is quite important to use the S value lower than the above indicated numbers.

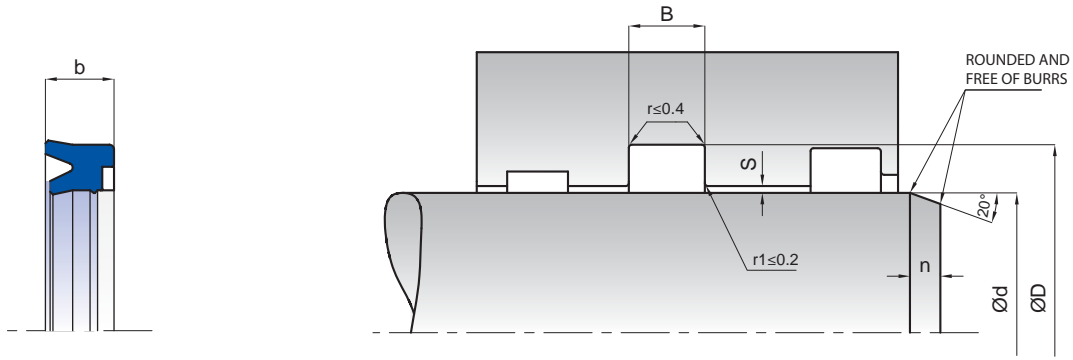

KASTAŞ NO	d (f8)	D (H11)	B (-0/+0.2)	b	n
K32-019 PU	19.05	25.4	7.35	6.35	3
K32-022 PU	22	30	7	6	4
K32-025 PU	25	35	6	5	4
K32-025/1 PU	25.4	31.75	7.35	6.35	3
K32-028 PU	28	38	7	6	4
K32-028/1 PU	28	35.5	6	5	4
K32-030 PU	30	40	9	8	4
K32-031 PU	31.75	38.1	7.1	6.05	3
K32-032 PU	32	45	10.5	9.5	6
K32-034 PU	34.92	41.27	7.35	6.35	3
K32-035 PU	35	45	9	8	4
K32-035/1 PU	35	45	8	7	4
K32-036 PU	36	46	9	8	4
K32-038 PU	38.1	44.45	7.35	6.35	3
K32-040 PU	40	50	11	10	4
K32-040/1 PU	40	52	13	12	6
K32-044 PU	44.45	53.97	10.5	9.52	4
K32-044/1 PU	44.45	50.8	7.35	6.35	3
K32-045 PU	45	55	11	10	4
K32-050 PU	50	60	11	10	4
K32-050/1 PU	50	62	9	8	6
K32-050/2 PU	50.8	57.15	7.35	6.35	3
K32-052 PU	52	68	11	10	6.5
K32-055 PU	55	65	11	10	4
K32-055/1 PU	55	65	13	12	4
K32-056 PU	56	71	11	10	6.5
K32-060 PU	60	70	11	10	4
K32-063 PU	63	75	9	8	6
K32-065 PU	65	80	13	12	6.5
K32-070 PU	70	80	11	10	4
K32-070/1 PU	70	82	13	12	6
K32-075 PU	75	85	13	12	4
K32-080 PU	80	90	13	12	4
K32-085 PU	85	100	13	12	6.5
K32-090 PU	90	100	13	12	4
K32-095 PU	95	105	13	12	4
K32-100 PU	100	115	13	12	6.5
K32-100/1 PU	100	120	13	12	7
K32-105 PU	105	115	13	12	4
K32-110/1 PU	110	130	16	15	7
K32-110 PU	110	125	15.6	14.6	6.5
K32-115 PU	115	125	13	12	4
K32-120 PU	120	140	15.6	14.6	7
K32-130 PU	130	140	13	12	4
K32-135 PU	135	145	13	12	4
K32-140 PU	140	160	15.6	14.6	7
K32-160 PU	160	170	13	12	4
K32-195 PU	195	215	16	15	7
K32-210 PU	210	235	19.2	18.2	7



20 horizontal light gray lines for writing.



K33 is a single acting rod seal designed to have inner lip shorter than the outer lip and additional sealing lip which improves the leakage behavior and, at the same time, prevents the penetration of dirt from the wiper side.

PRODUCT ADVANTAGES

- High wear resistant
- Superior sealing effect with the secondary lip
- Secondary sealing lip provides extra protection against the ingress of dirt particles
- Wide range of dimensions
- Simple groove design
- Easy assembly into closed grooves

APPLICATION

Construction machinery, fork-lift trucks, injection moulding machines, agricultural machinery, loading platforms and standard cylinders.

MATERIAL		CODE
PU	94 SHR 1	PU9401

OPERATING CONDITIONS			
MEDIA	Mineral oils (DIN 51524)	HFA and HFB	HFC
TEMPERATURE	-30°C +100°C	+5°C +50°C	-30°C +40°C
PRESSURE	≤400 Bar	≤400 Bar	≤400 Bar
SPEED	≤0.5 m/sec	≤0.5 m/sec	≤0.5 m/sec

Note: The above data are maximum values and cannot be used at the same time.

SURFACE ROUGHNESS		Ra	Rmax
Sliding Surface	Ød	≤0.4 µm	≤3.2 µm
Groove Base	ØD	≤1.6 µm	≤10 µm
Groove Flanks	B	≤3.2 µm	≤16 µm

Note: It is recommended to have 50% to 90% of the working surface material contact area value.

INSTALLATION

Easily assembled into closed grooves according to the minimum diameter values that are given in the below table. Open grooves or special assembly tools should be used for the values that are outside this table. It is very important that the assembly tools must be of soft material and have no sharp edges. Before installation the sealing element must be oiled with system oil.

MINIMUM DIAMETER VALUES FOR CLOSED TYPE OF GROOVES							
(D-d)/2 (mm)	4	5	6	7.7	10	12.5	15
d min (mm)	25	30	40	50	80	100	105

NOTES

The permissible sealing gap values of K33 rod seal is given in the below table.

PERMISSIBLE SEALING GAP			
NBR	Smax (mm)		
t=(D-d)/2 (mm)	150 Bar	250 Bar	400 Bar
t≤5	0.30	0.20	0.15
t>5	0.35	0.25	0.20

Note: The largest sealing gap value occurring on the non-pressurized side of the seal does have a vital importance for the function of the seal and in this respect it is quite important to use the S value lower than the above indicated numbers.

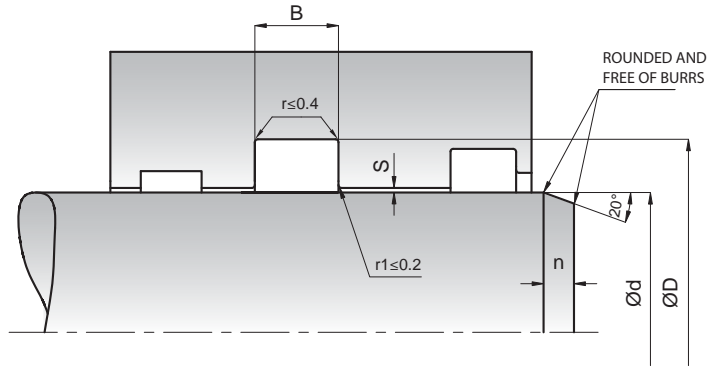
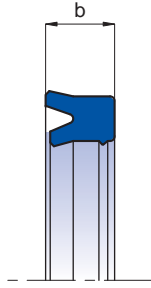

KASTAŞ NO	d (f8)	D (H11)	B (-0/+0.2)	b	n
K33-006 PU	6	9	4	3.5	2
K33-012/1 PU	12	22	8	7	4.5
K33-014 PU	14	24	8.2	7.2	4.5
K33-016 PU	16	22	5	4.5	3
K33-018 PU	18	24	5.9	4.9	3
K33-018/1 PU	18	26	9	8	4
K33-020 PU	20	30	7	6	4.5
K33-020/1 PU	20	30	9	8	4.5
K33-020/2 PU	20	28	7	6	4
K33-020/3 PU	20	30	11	10	4.5
K33-020/4 PU	20	26	6.5	5.5	3
K33-020/5 PU	20	26	6	5	3
K33-020/6 PU	20	28	9	8	4
K33-022 PU	22	30	8	7	4
K33-022/1 PU	22	32	7	6	4.5
K33-022/2 PU	22	32	9	8	4.5
K33-022/3 PU	22	30	9	8	4
K33-022/4 PU	22	32	8	7	4.5
K33-025 PU	25	35	7	6	4.5
K33-025/1 PU	25	40	11	10	5.5
K33-025/2 PU	25	33	7	6	4
K33-025/3 PU	25	35	8	7	4.5
K33-025/7 PU	25	33	6.5	5.5	4
K33-025/9 PU	25	33	7.5	6.5	4
K33-025/5 PU	25	33	7.8	6.8	4
K33-025/6 PU	25	33	8.3	7.3	4
K33-025/4 PU	25	33	9	8	4
K33-025/10 PU	25	35	9	8	4.5
K33-025/11 PU	25	35	11	10	4.5
K33-025/12 PU	25	33	11	10	4
K33-025/8 PU	25.4	31.50	5.75	4.75	3
K33-028 PU	28	38	11	10	4.5
K33-028/2 PU	28	36	6.8	5.8	4
K33-028/1 PU	28	38	8	7	4.5
K33-030 PU	30	40	9	8	4.5
K33-030/1 PU	30	45	11	10	5.5
K33-030/2 PU	30	40	8	7	4.5
K33-030/3 PU	30	40	11	10	4.5
K33-030/4 PU	30	42	11	10	5
K33-030/5 PU	30	43	10	9	5
K33-030/7 PU	30	38	7	6	4
K33-030/6 PU	30	38	8	7	4
K33-031 PU	31.75	38.1	7.35	6.35	3
K33-032 PU	32	40	7	6	4
K33-032/1 PU	32	40	8	7	4
K33-032/2 PU	32	42	11	10	4.5
K33-032/4 PU	32	40	9	8	4
K33-032/5 PU	32	42	7	6	4.5
K33-032/3 PU	32	42	8.3	7.3	4.5

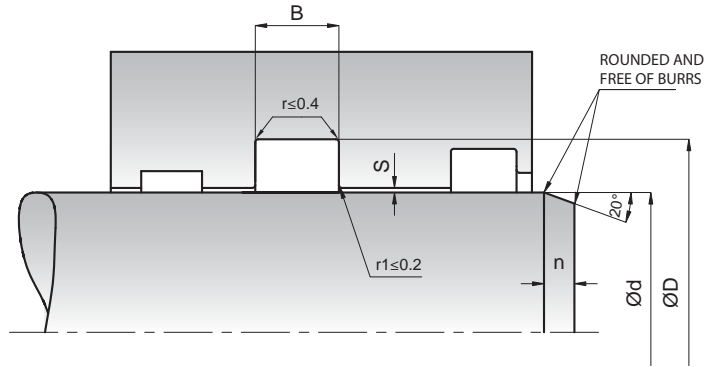
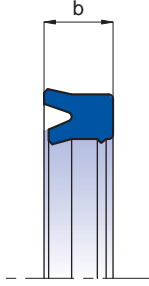

KASTAŞ NO	d (f8)	D (H11)	B (-0/+0.2)	b	n
K33-035 PU	35	45	9	8	4.5
K33-035/1 PU	35	50	11	10	5.5
K33-035/2 PU	35	43	6.7	5.7	4
K33-035/5 PU	35	43	7	6	4
K33-035/4 PU	35	43	8	7	4
K33-035/3 PU	35	45	11	10	4.5
K33-036 PU	36	46	9	8	4.5
K33-036/1 PU	36	51	11	10	5.5
K33-036/2 PU	36	52	11	10	6
K33-036/3 PU	36	46	8.3	7.3	4.5
K33-036/4 PU	36	44	7	6	4
K33-038 PU	38	48	10	9	4.5
K33-038/1 PU	38	50	7	6	5
K33-040 PU	40	50	11	10	4.5
K33-040/1 PU	40	55	11	10	5.5
K33-040/2 PU	40	50	8.3	7.3	4.5
K33-040/3 PU	40	60	12.5	11.5	6
K33-040/4 PU	40	48	6.7	5.7	4
K33-040/5 PU	40	50	10	9	4.5
K33-040/6 PU	40	50	8	7	4.5
K33-040/7 PU	40	55	12.5	11.5	5.5
K33-042 PU	42	50	6.7	5.7	4
K33-045 PU	45	55	11	10	4.5
K33-045/1 PU	45	60	11	10	5.5
K33-045/2 PU	45	55	8	7	4.5
K33-045/3 PU	45	55	8.3	7.3	4.5
K33-045/4 PU	45	60	12.5	11.5	5.5
K33-050 PU	50	60	11	10	4.5
K33-050/1 PU	50	65	11	10	5.5
K33-050/2 PU	50	60	13	12	4.5
K33-050/3 PU	50	60	8.5	7.5	4.5
K33-050/6 PU	50	60	8	7	4.5
K33-050/4 PU	50	60	8.3	7.3	4.5
K33-050/5 PU	50	65	12.5	11.5	5.5
K33-055 PU	55	65	11	10	4.5
K33-055/1 PU	55	63	12.5	11.5	4
K33-055/2 PU	55	70	12.5	11.5	5.5
K33-056 PU	56	66	9	8	4.5
K33-060 PU	60	80	13	12	6
K33-060/3 PU	60	70	11	10	4.5
K33-060/1 PU	60	70	12.5	11.5	4.5
K33-060/2 PU	60	75	13	12	5.5
K33-060/6 PU	60	70	8	7	4.5
K33-060/4 PU	60	70	13	12	4.5
K33-060/5 PU	60	75	11	10	5.5
K33-063 PU	63	83	13	12	6
K33-063/2 PU	63	78	11	10	5.5
K33-063/1 PU	63	78	12.5	11.5	5.5
K33-063/5 PU	63	73	13	12	4.5

KASTAŞ NO	d (f8)	D (H11)	B (-0/+0.2)	b	n
K33-063/3 PU	63.5	82.55	16.87	15.87	6
K33-063/4 PU	63.5	73.02	10.52	9.52	4
K33-065 PU	65	75	11	10	4.5
K33-065/1 PU	65	75	12.5	11.5	4.5
K33-065/3 PU	65	75	14	13	4.5
K33-070 PU	70	80	13	12	4.5
K33-070/1 PU	70	78	12.5	11.5	4
K33-070/2 PU	70	80	12.5	11.5	4.5
K33-070/3 PU	70	85	12.5	11.5	5.5
K33-070/4 PU	70	85	13	12	5.5
K33-070/5 PU	70	90	13	12	6
K33-070/6 PU	70	85	14	13	5.5
K33-070/7 PU	70	80	7	6	4.5
K33-075 PU	75	85	13	12	4.5
K33-075/1 PU	75	83	12.5	11.5	4
K33-075/2 PU	75	85	12.5	11.5	4.5
K33-075/3 PU	75	90	13	12	5.5
K33-077 PU	77	87	13	12	4.5
K33-080 PU	80	90	13	12	4.5
K33-080/1 PU	80	88	12.5	11.5	4
K33-080/2 PU	80	95	12.5	11.5	5.5
K33-080/5 PU	80	95	13	12	5.5
K33-080/3 PU	80	100	13	12	6
K33-080/4 PU	80	100	16	15	6
K33-080/7 PU	80	95	11	10	5.5
K33-080/6 PU	80	100	11	10	6
K33-085 PU	85	95	13	12	4.5
K33-085/1 PU	85	93	13	12	4
K33-085/2 PU	85	100	13	12	5.5
K33-085/3 PU	85	105	13	12	6
K33-090 PU	90	100	13	12	4.5
K33-090/1 PU	90	98	12.5	11.5	4
K33-090/2 PU	90	100	11	10	4.5
K33-090/4 PU	90	98	11.9	10.9	4
K33-090/7 PU	90	100	12.5	11.5	4.5
K33-090/5 PU	90	105	13	12	5.5
K33-090/3 PU	90	110	11	10	6
K33-090/6 PU	90	110	14	13	6
K33-090/11 PU	90	105	12.5	11.5	5.5
K33-090/8 PU	90	100	8	7	4.5
K33-090/9 PU	90	110	13	12	6
K33-090/10 PU	90	110	16	15	6
K33-095 PU	95	105	13	12	4.5
K33-095/1 PU	95	103	12.5	11.5	4
K33-095/2 PU	95	110	11	10	5.5
K33-095/3 PU	95	115	13	12	6
K33-100 PU	100	115	13	12	5.5
K33-100/1 PU	100	110	12.5	11.5	4.5
K33-100/2 PU	100	108	12.5	11.5	4
K33-100/3 PU	100	115	12	11	5.5
K33-100/4 PU	100	120	13	12	6
K33-100/5 PU	100	130	13	12	8
K33-100/7 PU	100	120	15	14	6
K33-100/6 PU	100	125	16	15	7
K33-105 PU	105	115	13	12	4.5
K33-105/1 PU	105	120	11	10	5.5
K33-105/2 PU	105	113	12.5	11.5	4
K33-105/3 PU	105	115	12.5	11.5	4.5
K33-106 PU	106	120	9.4	8.4	5.5
K33-110 PU	110	118	12.5	11.5	4
K33-110/1 PU	110	125	13	12	5.5
K33-110/2 PU	110	130	16	15	6
K33-110/3 PU	110	125	12	11	5.5
K33-110/5 PU	110	125	16	15	5.5
K33-110/4 PU	110	130	13	12	6
K33-113 PU	113	128	13	12	5.5

Please contact our customer service for the dimensions out of our stock list.

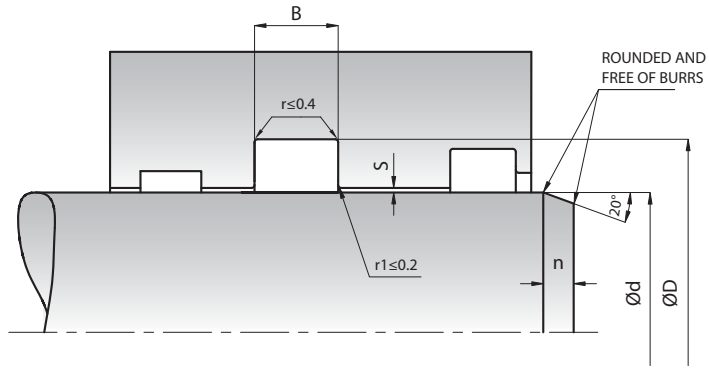
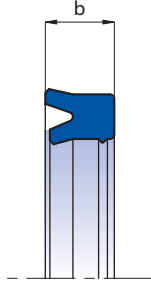

KASTAŞ NO	d (f8)	D (H11)	B (-0/+0.2)	b	n
K33-115 PU	115	125	13	12	4.5
K33-115/1 PU	115	135	13	12	6
K33-118 PU	118	126	12.5	11.5	4
K33-120/3 PU	120	130	12.5	11.5	4.5
K33-120/1 PU	120	135	16	15	5.5
K33-120/2 PU	120	140	13	12	6
K33-120 PU	120	140	16	15	6
K33-120/5 PU	120	140	15.6	14.6	6
K33-120/4 PU	120	150	16	15	8
K33-123 PU	123	132	13	12	4
K33-125 PU	125	150	15	14	7
K33-125/1 PU	125	145	16	15	6
K33-125/2 PU	125	133	12.5	11.5	4
K33-125/4 PU	125	135	13	12	4.5
K33-125/3 PU	125	145	13	12	6
K33-130 PU	130	145	10	9	5.5
K33-130/1 PU	130	138	12.5	11.5	4
K33-130/2 PU	130	150	16	15	6
K33-135 PU	135	145	13	12	4.5
K33-135/1 PU	135	150	12.5	11.5	5.5
K33-140/3 PU	140	150	12.5	11.5	4.5
K33-140/2 PU	140	160	13	12	6
K33-140/1 PU	140	160	15.5	14.5	6
K33-140 PU	140	160	16	15	6
K33-140/4 PU	140	170	19	18	8
K33-142 PU	142	157	13	12	5.5
K33-143 PU	143	151	12.5	11.5	4
K33-145 PU	145	155	13	12	4.5
K33-150 PU	150	170	15	14	6
K33-150/2 PU	150	170	13	12	6
K33-150/1 PU	150	180	19	18	8
K33-155 PU	155	165	13	12	4.5
K33-155/1 PU	155	163	12.5	11.5	4
K33-160 PU	160	170	13	12	4.5
K33-160/1 PU	160	185	16	15	7
K33-160/3 PU	160	180	16	15	6
K33-160/2 PU	160	170	12.5	11.5	4.5
K33-165/1 PU	165	175	13	12	4.5
K33-165 PU	165.1	177.8	10.52	9.52	5
K33-170 PU	170	200	16	15	8
K33-172 PU	172	187	13	12	5.5
K33-172/1 PU	172	197	16	15	7
K33-175/1 PU	175	185	13	12	4.5
K33-175 PU	175	215	21	20	10
K33-180 PU	180	200	16	15	6
K33-180/1 PU	180	195	12.5	11.5	5.5
K33-185 PU	185	195	13	12	4.5
K33-190 PU	190	210	16	15	6
K33-190/1 PU	190.5	203.2	10.52	9.52	5



K34 is a three piece single acting sealing set which consists of one reinforced cotton fabric or thermoplastic elastomer back-up ring, one specially designed multiple lip elastomeric nitrile rubber sealing element and one thermoplastic anti-extrusion ring.

PRODUCT ADVANTAGES

- Effective sealing during vibration and shock loading
- Improved sealing gap due to the active anti-extrusion ring
- Superior sealing effect in high pressures
- Alternative design to packings

APPLICATION

Earth moving equipment, excavators, cranes, loading platforms, and special machinery.

MATERIAL		CODE
NBR	80 SHORE A	NB8001
COTTON FABRIC NBR		NB8008
TPE		TP5501
POM		PM9901

OPERATING CONDITIONS			
MEDIA	Mineral oils (DIN 51524)	HFA and HFB	HFC
TEMPERATURE	-30°C +105°C	+5°C +60°C	-30°C +60°C
PRESSURE	≤700 Bar	≤700 Bar	≤700 Bar
SPEED	≤0.5 m/sec	≤0.5 m/sec	≤0.5 m/sec

Note: The above data are maximum values and cannot be used at the same time.

SURFACE ROUGHNESS		Ra	Rmax
Sliding Surface	Ød	≤0.4 µm	≤3.2 µm
Groove Base	ØD	≤1.6 µm	≤6.3 µm
Groove Flanks	B	≤3.2 µm	≤16 µm

Note: It is recommended to have 50% to 90% of the working surface material contact area value.

INSTALLATION

Assembly into the open grooves. If it is necessary to have a closed groove, back-up ring should be cut with 75° angle in a way not to have any extrusion gap and installed afterwards. It is very important that the assembly tools must be of soft material and have no sharp edges. Before installation all individual parts of the seal must be oiled with system oil.

NOTES

For special applications that require high temperatures, our seal set can be manufactured in the following configuration, FKM header ring, back-up ring and anti-extrusion rings from special mixture of PTFE material.

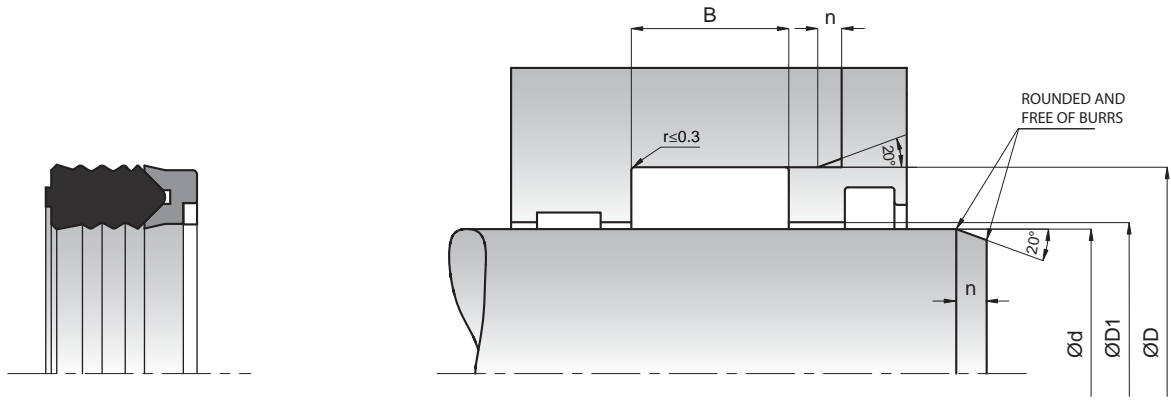
K34 ROD SEAL

KASTAŞ NO	d (f8)	D (H10)	B (-0/+0.4)	D1 (±0.1)	n
K34-032	32	47	22.5	32.4	5
K34-035	35	47	22.5	35.4	5
K34-040	40	55	22.5	40.4	5
K34-045	45	60	22.5	45.4	5
K34-050	50	65	22.5	50.4	5
K34-050/1	50	65	24.5	50.4	5
K34-055	55	70	22.5	55.4	5
K34-060	60	75	22.5	60.4	5
K34-070	70	85	22.5	70.4	5
K34-070/1	70	90	30	70.4	5
K34-080	80	100	30	80.4	5
K34-085	85	95	22.5	85.4	5
K34-090	90	110	30	90.4	5
K34-100	100	120	30	100.4	5
K34-110	110	130	32.5	110.4	7
K34-115	115	130	30	115.7	7
K34-115/1	115	125	22.5	115.7	7
K34-120	120	140	30	120.7	7
K34-125	125	145	29.6	125.7	7
K34-140/1	140	160	30	140.7	7
K34-160	160	180	28	160.7	7
K34-180	180	205	35	180.7	7



K35 is a two piece single acting rod seal which consists of one special mixture PTFE profile ring and an o-ring as energizing element.

PRODUCT ADVANTAGES

- Low friction, free of stick-slip
- Thanks to the special profile it can be used in pair or in front of the u-ring
- Long service life
- High sliding speed
- Wide range of temperature and chemicals depending on the o-ring material
- Minimum static and dynamic friction coefficient for a minimum energy loss and operating temperature
- Simple groove design and low axial housing heights

APPLICATION

Injection moulding machines, fork-lift trucks, loading platforms, cranes, agricultural machinery, hydraulic breakers and servo cylinders.

MATERIAL		CODE
NBR	70 SHORE A	NB7001
PTFE		PT6003

OPERATING CONDITIONS

MEDIA	Mineral oils (DIN 51524)	HFA and HFB	HFC
TEMPERATURE	-30°C +105°C	+5°C +60°C	-30°C +60°C
PRESSURE	≤400 Bar	≤400 Bar	≤400 Bar
SPEED	≤5.0 m/sec	≤5.0 m/sec	≤5.0 m/sec

Note: The above data are maximum values and cannot be used at the same time.

SURFACE ROUGHNESS		Ra	Rmax
Sliding Surface	Ød	≤0.2 µm	≤2.0 µm
Groove Base	ØD	≤1.6 µm	≤6.3 µm
Groove Flanks	B	≤3.2 µm	≤15 µm

Note: It is recommended to have 50% to 90% of the working surface material contact area value.

INSTALLATION

We recommend using special assembly tool (See section; Hydraulic Sealing Elements General Installation Information). It is very important that the assembly tools must be of soft material and have no sharp edges. Before installation the sealing element must be oiled with system oil.

NOTES

K35 type of rod seal can be also used with double lip wipers. For special applications that require high temperatures or resistance to chemicals, piston seal is being manufactured with special mixture PTFE and FKM material. For heavy duty applications and high pressures the tolerances should change to H8/f8 and please contact our customer service to choose the suitable sealing element. The permissible sealing gap values of K35 rod seal is given in the below table.

PERMISSIBLE SEALING GAP

B (mm)	Smax (mm)		
	150 bar	250 bar	400 bar
2.2	0.25	0.15	0.10
3.2	0.35	0.20	0.10
4.2	0.35	0.20	0.15
6.3	0.45	0.25	0.15
8.1	0.55	0.30	0.20
8.1	0.55	0.30	0.20

Note: The largest sealing gap value occurring on the non-pressurized side of the seal does have a vital importance for the function of the seal and in this respect it is quite important to use the S value lower than the above indicated numbers.

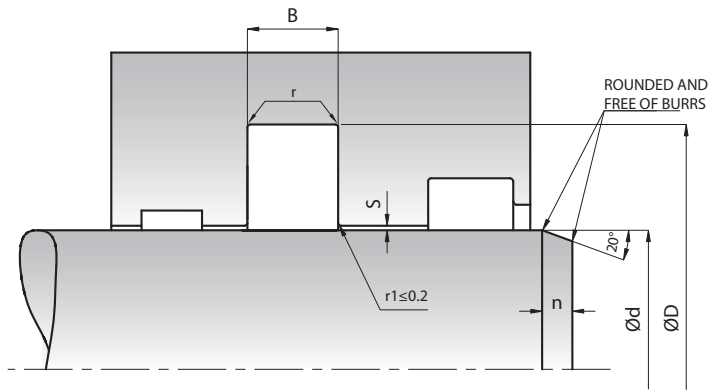
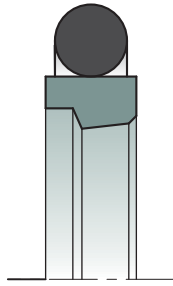

KASTAŞ NO	d (f8)	D (H9)	B (-0/+0.2)	r	n	O-Ring
K35-008	8	12.9	2.2	0.4	2	9.66x1.78
K35-010	10	14.9	2.2	0.4	2	11.11x1.78
K35-012	12	19.3	3.2	0.6	3	13.95x2.62
K35-014	14	21.3	3.2	0.6	3	17.13x2.62
K35-016	16	23.3	3.2	0.6	3	18.72x2.62
K35-018	18	25.3	3.2	0.6	3	20.29x2.62
K35-018/1	18	22.9	2.2	0.4	2	18.77x1.78
K35-020	20	30.7	4.2	1	3.5	24.99x3.53
K35-020/1	20	27.3	3.2	0.6	3	22.22x2.62
K35-022	22	32.7	4.2	1	3.5	26.58x3.53
K35-022/1	22	29.3	3.2	0.6	3	25.07x2.62
K35-025	25	35.7	4.2	1	3.5	31.34x3.53
K35-025/1	25	32.3	3.2	0.6	3	28.25x2.62
K35-026	26	36.7	4.2	1	3.5	31.34x3.53
K35-028	28	38.7	4.2	1	3.5	32.92x3.53
K35-028/1	28	35.3	4.2	1	3	29.82x2.62
K35-030	30	40.7	4.2	1	3.5	34.52x3.53
K35-030/1	30	37.3	3.2	0.6	3	33.00x2.62
K35-032	32	42.7	4.2	1	3.5	36.09x3.53
K35-032/1	32	39.3	3.2	0.6	3	34.59x2.62
K35-035	35	45.7	4.2	1	3.5	37.69x3.53
K35-035/1	35	42.3	3.2	0.6	3	37.77x2.62
K35-036	36	46.7	4.2	1	3.5	40.87x3.53
K35-036/1	36	43.3	3.2	0.6	3	39.34x2.62
K35-038	38	48.7	4.2	1	3.5	40.87x3.53
K35-040	40	55.1	6.3	1.3	5.5	43.82x5.33
K35-040/1	40	50.7	4.2	1	3.5	44.45x3.53
K35-045	45	60.1	6.3	1.3	5.5	50.16x5.33
K35-045/1	45	55.7	4.2	1	3.5	50.39x3.53
K35-048	48	63.1	6.3	1.3	5.5	53.34x5.33
K35-048/1	48	58.7	4.2	1	3.5	50.80x3.53
K35-050	50	65.1	6.3	1.3	5.5	56.52x5.33
K35-050/1	50	60.7	4.2	1	3.5	53.57x3.53
K35-052	52	62.7	4.2	1	3.5	56.74x3.53
K35-052/1	52	67.1	6.3	1.3	5.5	56.52x5.33
K35-055	55	70.1	6.3	1.3	5.5	59.69x5.33
K35-056	56	71.1	6.3	1.3	5.5	62.87x5.33
K35-056/1	56	66.7	4.2	1	3.5	59.92x3.53
K35-060	60	75.1	6.3	1.3	5.5	66.04x5.33
K35-060/1	60	70.7	4.2	1	3.5	63.09x3.53
K35-063	63	78.1	6.3	1.3	5.5	69.22x5.33
K35-063/1	63	73.7	4.2	1	3.5	66.04x3.53
K35-065	65	80.1	6.3	1.3	5.5	69.22x5.33
K35-067	67	82.1	6.3	1.3	5.5	72.40x5.33
K35-068	68	83.1	6.3	1.3	5.5	72.40x5.33
K35-068/1	68	78.7	4.2	1	3.5	72.62x3.53
K35-070	70	85.1	6.3	1.3	5.5	75.57x5.33
K35-070/1	70	80.7	4.2	1	3.5	75.79x3.53
K35-073	73	88.1	6.3	1.3	5.5	78.74x5.33

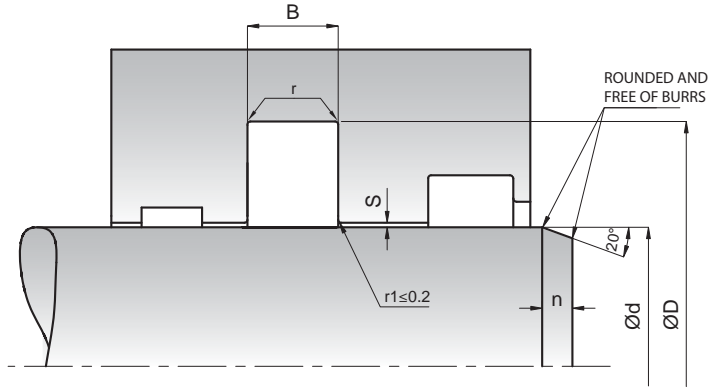
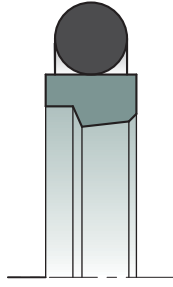

KASTAŞ NO	d (f8)	D (H9)	B (-0/+0.2)	r	n	O-Ring
K35-075	75	90.1	6.3	1.3	5.5	81.92x5.33
K35-080	80	95.1	6.3	1.3	5.5	85.09x5.33
K35-080/1	80	90.7	4.2	1	3.5	85.32x3.53
K35-085	85	100.1	6.3	1.3	6	91.44x5.33
K35-090	90	105.1	6.3	1.3	6	94.62x5.33
K35-095	95	110.1	6.3	1.3	6	100.97x5.33
K35-095/1	95	115.1	8.1	1.8	7.5	104.14x6.99
K35-100	100	115.1	6.3	1.3	6	107.32x5.33
K35-100/1	100	110.7	4.2	1	3.5	104.37x3.53
K35-105	105	125.5	8.1	1.8	7.5	113.67x6.99
K35-105/1	105	120.1	6.3	1.3	6	110.49x5.33
K35-110	110	125.1	6.3	1.3	6	116.84x5.33
K35-110/1	110	130.5	8.1	1.8	7.5	116.84x6.99
K35-110/2	110	120.7	4.2	1	3.5	113.89x3.53
K35-115	115	130.1	6.3	1.3	6	120.02x5.33
K35-120	120	135.1	6.3	1.3	6	126.57x5.33
K35-125	125	140.1	6.3	1.3	6	130.18x5.33
K35-125/1	125	145.5	8.1	1.8	7.5	132.72x6.99
K35-130	130	145.1	6.3	1.3	6	135.89x5.33
K35-130/1	130	150.5	8.1	1.8	7.5	139.07x6.99
K35-135	135	150.1	6.3	1.3	6	137.70x5.33
K35-138	138	153.1	6.3	1.3	6	142.24x5.33
K35-140	140	155.1	6.3	1.3	6	145.42x5.33
K35-145	145	160.1	6.3	1.3	6	151.77x5.33
K35-150	150	165.1	6.3	1.3	6	151.77x5.33
K35-150/1	150	170.5	8.1	1.8	7.5	158.12x6.99
K35-155	155	170.1	6.3	1.3	6	161.30x5.33
K35-160	160	175.1	6.3	1.3	6	164.47x 5.33
K35-160/1	160	180.5	8.1	1.8	7.5	164.47x6.99
K35-165	165	180.1	6.3	1.3	6	170.82x5.33
K35-170	170	185.1	6.3	1.3	6	177.17x5.33
K35-170/1	170	190.5	8.1	1.8	7.5	177.17x6.99
K35-175	175	190.1	6.3	1.3	6	177.17x5.33
K35-180	180	195.1	6.3	1.3	6	183.52x5.33
K35-185	185	200.1	6.3	1.3	6	189.87x5.33
K35-190	190	205.1	6.3	1.3	6	196.22x5.33
K35-192	192	207.1	6.3	1.3	6	196.22x5.33
K35-195	195	210.1	6.3	1.3	6	202.57x5.33
K35-200	200	220.5	8.1	1.8	7.5	208.92x6.99
K35-210	210	230.5	8.1	1.8	7.5	215.27x6.99
K35-215	215	235.5	8.1	1.8	7.5	227.97x6.99
K35-220	220	240.5	8.1	1.8	7.5	227.97x6.99
K35-225	225	245.5	8.1	1.8	7.5	240.67x6.99
K35-230	230	250.5	8.1	1.8	7.5	240.67x6.99
K35-235	235	255.5	8.1	1.8	7.5	240.67x6.99
K35-240	240	260.5	8.1	1.8	7.5	240.67x6.99
K35-245	245	265.5	8.1	1.8	7.5	253.57x6.99
K35-250	250	270.5	8.1	1.8	7.5	253.57x6.99
K35-260	260	284	8.1	1.8	8	266.07x6.99

KASTAŞ NO	d (f8)	D (H9)	B (-0/+0,2)	r	n	O-Ring
K35-260/1	260	280.5	8.1	1.8	7.5	266.07x6.99
K35-270	270	294	8.1	1.8	8	278.77x6.99
K35-275	275	299	8.1	1.8	8	291.47x6.99
K35-280	280	304	8.1	1.8	8	291.47x6.99
K35-285	285	309	8.1	1.8	8	291.47x6.99
K35-290	290	314	8.1	1.8	8	297.88x6.99
K35-295	295	319	8.1	1.8	8	304.17x6.99
K35-300	300	324	8.1	1.8	8	316.87x6.99
K35-300/1	300	320.5	8.1	1.8	7.5	304.17x6.99
K35-300	300	324	8.1	1.8	8	316.87x6.99
K35-310	310	334	8.1	1.8	8	316.87x6.99
K35-320	320	344	8.1	1.8	8	329.57x6.99
K35-330	330	354	8.1	1.8	8	342.27x6.99
K35-340	340	364	8.1	1.8	8	354.97x6.99
K35-345	345	369	8.1	1.8	8	354.97x6.99
K35-350	350	374	8.1	1.8	8	354.9x6.99
K35-360	360	384	8.1	1.8	8	367.67x6.99
K35-370	370	394	8.1	1.8	8	380.37x6.99
K35-380	380	404	8.1	1.8	8	393.07x6.99
K35-390	390	414	8.1	1.8	8	405.26x6.99
K35-400	400	424	8.1	1.8	8	417.96x6.99
K35-405	405	429	8.1	1.8	8	417.96x6.99
K35-420	420	444	8.1	1.8	8	430.66x6.99
K35-430	430	454	8.1	1.8	8	443.36x6.99
K35-450	450	474	8.1	1.8	8	468.76x6.99
K35-460	460	484	8.1	1.8	8	468.76x6.99
K35-470	470	494	8.1	1.8	8	481.46x6.99
K35-480	480	504	8.1	1.8	8	494.16x6.99
K35-490	490	514	8.1	1.8	8	506.86x6.99
K35-500	500	524	8.1	1.8	8	506.86x6.99
K35-510	510	534	8.1	1.8	8	532.26x6.99
K35-520	520	544	8.1	1.8	8	532.26x6.99
K35-530	530	554	8.1	1.8	8	557.66x6.99
K35-550	550	574	8.1	1.8	8	582.68x6.99
K35-570	570	594	8.1	1.8	8	582.68x6.99



K37 is a two piece single acting rod seal which consists of a reinforced cotton fabric and nitrile rubber vulcanized together forming an integral sealing element and one thermoplastic back-up ring.

PRODUCT ADVANTAGES

- Functions well even with poor surfaces
- Reinforced cotton fabric base prevents the seal from extrusion
- Good sealing effect at low pressures
- Improved sealing gap due to the active back-up ring

APPLICATION

Mining equipment, after market, mobile hydraulics, presses and standard cylinders.

MATERIAL	CODE
NBR 80 SHORE A	NB8001
COTTON FABRIC NBR	NB8008
POM	PM9901

OPERATING CONDITIONS

MEDIA	Mineral oils (DIN 51524)	HFA and HFB	HFC
TEMPERATURE	-30°C +105°C	+5°C +60°C	-30°C +60°C
PRESSURE	≤400 Bar	≤400 Bar	≤400 Bar
SPEED	≤0.5 m/sec	≤0.5 m/sec	≤0.5 m/sec

Note: The above data are maximum values and cannot be used at the same time.

SURFACE ROUGHNESS		Ra	Rmax
Sliding Surface	Ød	≤0.4 µm	≤3.2 µm
Groove Base	ØD	≤1.8 µm	≤6.3 µm
Groove Flanks	B	≤3.2 µm	≤16 µm

Note: It is recommended to have 50% to 90% of the working surface material contact area value.

INSTALLATION

K37 is to be assembled into open grooves. It is very important that the assembly tools must be of soft material and have no sharp edges. Before installation all individual parts of the seal must be oiled with system oil.

NOTES

The permissible sealing gap values of K37 rod seal is given in the below table.

PERMISSIBLE SEALING GAP	
Pressure (Bar)	Smax (mm)
150	0.4
250	0.3
400	0.2

Note: The largest sealing gap value occurring on the non-pressurized side of the seal does have a vital importance for the function of the seal and in this respect it is quite important to use the S value lower than the above indicated numbers.

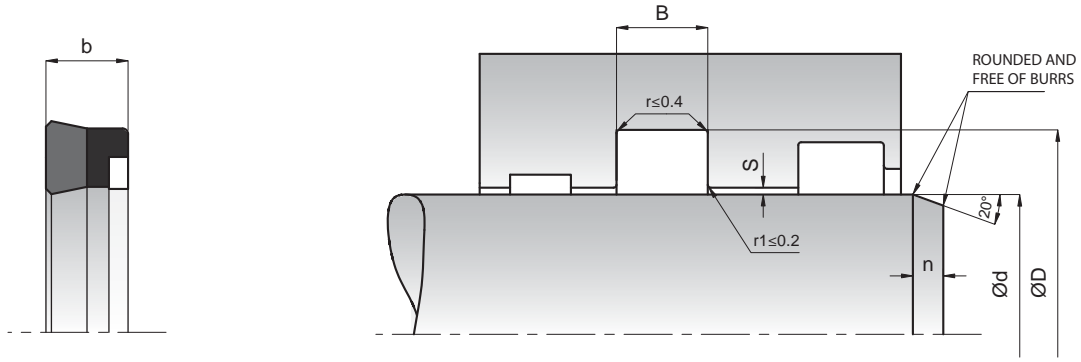

KASTAŞ NO	d (f8)	D (H9)	B (-0/+0.2)	b	n
K37-006	6	14	6.5	6.2	5
K37-012	12	23	7.5	7.2	5
K37-015	15	27	7	6.7	5
K37-016	16	28	7.5	7.2	5
K37-018	18	26	6.3	6	5
K37-018/1	18	28	6.3	6	5
K37-018/2	18	30	7.5	7.2	5
K37-020	20	30	8	7.7	5
K37-020/1	20	27	6	5.7	5
K37-020/2	20	28	6.3	6	5
K37-020/3	20	28	7	6.7	5
K37-020/4	20	30	8.5	8.2	5
K37-022	22	32	7.5	7.2	5
K37-022/1	22	29	5	4.7	5
K37-022/2	22	30	7	6.7	5
K37-022/3	22	32	10	9.7	5
K37-022/4	22	34	9.5	9.2	5
K37-022/5	22	35	10	9.7	5
K37-025	25	38	9.5	9.2	5
K37-025/1	25	33	6	5.7	5
K37-025/2	25	35	8	7.7	5
K37-025/3	25	33	6.4	6.1	5
K37-025/4	25	35	9	8.7	5
K37-025/5	25	38	10	9.7	5
K37-025/6	25.4	38.1	10	9.7	5
K37-028	28	38	8	7.7	5
K37-028/1	28	41	9.5	9.2	5
K37-028/2	28	36	6.5	6.2	5
K37-028/3	28	40	9.5	9.2	5
K37-028/4	28	41	10	9.7	5
K37-028/5	28.57	39.68	9.25	8.95	5
K37-030	30	40	10.5	10.2	5
K37-030/1	30	38	6.5	6.2	5
K37-030/2	30	40	7	6.7	5
K37-030/3	30	40	7.5	7.2	5
K37-030/4	30	45	9	8.7	5
K37-030/5	30	50	14.5	14.2	5
K37-031	31.75	47.62	11.6	11.3	5
K37-032	32	40	9	8.7	5
K37-032/1	32	42	11	10.7	5
K37-032/2	32	45	10	9.7	5
K37-034	32.92	50.8	8.5	8.2	5
K37-035	35	45	10.5	10.2	5
K37-035/1	35	50	10.5	10.2	5
K37-035/2	35	45	10	9.7	5
K37-035/3	35	50	11.5	11.2	5
K37-035/4	35	43	6	5.7	5
K37-036	36	43	6.5	6.2	5
K37-036/1	36	44	6.4	6.1	5

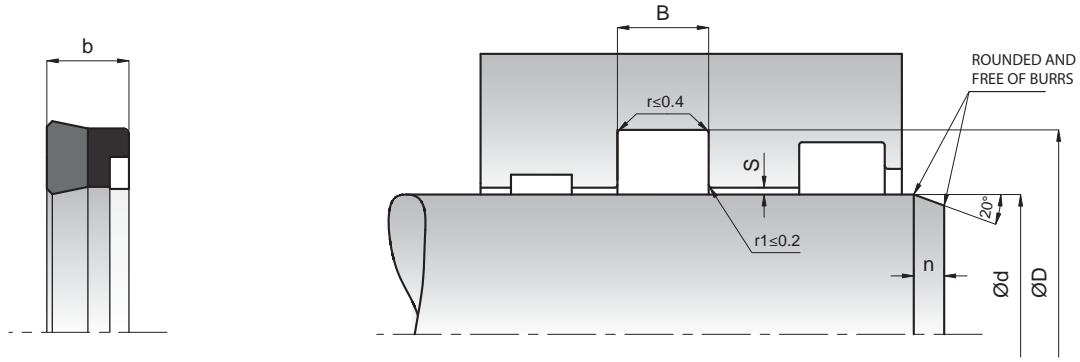

KASTAŞ NO	d (f8)	D (H9)	B (-0/+0.2)	b	n
K37-036/2	36	46	8.5	8.2	5
K37-036/3	36	48	12	11.7	5
K37-036/4	36	48	9.5	9.2	5
K37-038	38	55	10.5	10.2	5
K37-038/1	38.1	50.8	10	9.7	5
K37-038/2	38.1	53.97	10.5	10.2	5
K37-040	40	50	10.5	10.2	5
K37-040/1	40	55	10.5	10.2	5
K37-040/2	40	50	11	10.7	5
K37-040/3	40	48	6.5	6.2	5
K37-040/4	40	55	11	10.7	5
K37-040/5	40	50	10	9.7	5
K37-040/6	40	50	8	7.7	5
K37-040/7	40	55	8	7.7	5
K37-040/8	40	60	14.5	14.2	5
K37-042	42	52	9	8.7	5
K37-044	44.45	53.97	7.14	6.84	5
K37-044/1	44.45	53.97	7.62	7.32	5
K37-044/2	44.45	60.32	11.6	11.3	5
K37-045	45	55	10.5	10.2	5
K37-045/1	45	60	10.5	10.2	5
K37-045/2	45	55	11	10.7	5
K37-045/3	45	55	8	7.7	5
K37-045/4	45	55	7.5	7.2	5
K37-045/5	45	57	10	9.7	5
K37-045/6	45	65	14.5	14.2	5
K37-050	50	65	10.5	10.2	5
K37-050/1	50	62	10	9.7	5
K37-050/2	50	60	10.5	10.2	5
K37-050/3	50	60	10	9.7	5
K37-050/4	50	65	11	10.7	5
K37-050/5	50	62	8	7.7	5
K37-050/7	50	60	7.5	7.2	5
K37-050/8	50	60	8	7.7	5
K37-050/9	50	70	14.5	14.2	5
K37-054	54	66	9.5	9.2	5
K37-055	55	65	10.5	10.2	5
K37-055/1	55	65	12	11.7	5
K37-055/2	55	65	11	10.7	5
K37-055/3	55	75	14	13.7	5
K37-055/4	55	65	8	7.7	5
K37-055/5	55	70	10.5	10.2	5
K37-055/6	55	75	14.5	14.2	5
K37-056	56	66	10.5	10.2	5
K37-056/1	56	71	10.5	10.2	5
K37-056/2	56	76	14.5	14.2	5
K37-057	57.15	69.85	10	9.7	5
K37-060	60	70	10.5	10.2	5
K37-060/1	60	70	12.5	12.2	5

KASTAŞ NO	d (f8)	D (H9)	B (-0/+0.2)	b	n
K37-060/2	60	80	14	13.7	5
K37-060/11	60	80	14.5	14.2	5
K37-060/3	60	75	13	12.7	5
K37-060/4	60	75	12.5	12.2	5
K37-060/5	60	69.5	7	6.7	5
K37-060/6	60	70	11	10.7	5
K37-060/7	60	70	8	7.7	5
K37-060/8	60	70	13	12.7	5
K37-060/9	60	72	10	9.7	5
K37-063/1	63	75	11	10.7	5
K37-063/2	63	78	12.5	12.2	5
K37-063/3	63.5	83	14.5	14.2	5
K37-063/4	63.5	82.55	14.28	13.98	5
K37-063/5	63.5	76.2	8.5	8.2	5
K37-063/6	63.5	77.78	11.5	11.2	5
K37-065	65	80	12.5	12.2	5
K37-065/1	65	75	12.5	12.2	5
K37-065/2	65	75	13.5	13.2	5
K37-065/3	65	77	9.6	9.3	5
K37-065/4	65	80	11.5	11.2	5
K37-070	70	80	12.5	12.2	5
K37-070/1	70	85	12	11.7	5
K37-070/2	70	85	12.5	12.2	5
K37-070/3	70	90	14	13.7	5
K37-070/4	70	80	8	7.7	5
K37-070/5	70	80	13	12.7	5
K37-070/6	70	82	10.5	10.2	5
K37-070/7	70	84	12.5	12.2	5
K37-075	75	85	12.5	12.2	5
K37-075/1	75	90	11	10.7	5
K37-075/2	75	85	11	10.7	5
K37-075/3	75	90	11.5	11.2	5
K37-075/4	75	90	12.8	12.5	5
K37-075/5	75	95	14.5	14.2	5
K37-080	80	90	12.5	12.2	5
K37-080/1	80	100	12.5	12.2	5
K37-080/2	80	100	14	13.7	5
K37-080/3	80	95	12	11.7	5
K37-080/4	80	93	14.5	14.2	5
K37-080/5	80	96	10.5	10.2	5
K37-080/6	80	100	12	11.7	5
K37-080/7	80	100	14.5	14.2	5
K37-080/8	80	95	10	9.7	5
K37-085	85	100	12.5	12.2	5
K37-085/1	85	95	8	7.7	5
K37-085/2	85	100	12	11.7	5
K37-085/3	85	105	14.5	14.2	5
K37-088	88.9	114.3	19.5	19.2	5
K37-090	90	105	12.5	12.2	5
K37-090/1	90	110	12.5	12.2	5
K37-090/2	90	105	9.5	9.2	5
K37-090/4	90	106.5	10.8	10.5	5
K37-095	95	106.2	11	10.7	5
K37-095/1	95	112	12	11.7	5
K37-095/2	95	115	14.5	14.2	5
K37-100	100	115	12.5	12.2	7
K37-100/1	100	120	14	13.7	7
K37-100/2	100	125	19	18.7	7
K37-100/3	100	120	24.5	24.2	7
K37-100/4	100	115	11.5	11.2	7
K37-100/5	100	120	12	11.7	7
K37-100/6	100	120	14.5	14.2	7
K37-105	105	115	11	10.7	7
K37-105/1	105	125	12.5	12.2	7
K37-110	110	130	12.5	12.2	7

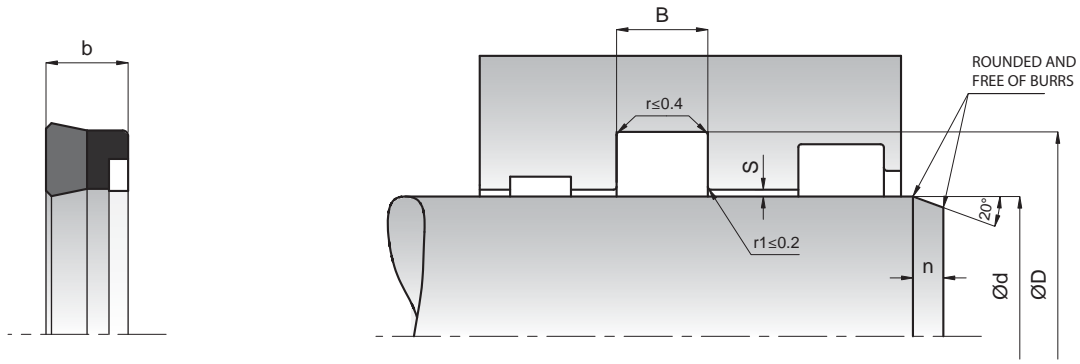

KASTAŞ NO	d (f8)	D (H9)	B (-0/+0.2)	b	n
K37-110/1	110	125	12	11.7	7
K37-110/2	110	135	15.5	15.2	7
K37-120	120	130	10.5	10.2	7
K37-120/1	120	132.7	10	9.7	7
K37-120/2	120	135	12.5	12.2	7
K37-120/3	120	140	12.5	12.2	7
K37-120/4	120	145	18.8	18.5	7
K37-125	125	150	14	13.7	7
K37-125/1	125	150	14.5	14.2	7
K37-130	130	145	13	12.7	7
K37-130/1	130	145	15	14.7	7
K37-130/2	130	150	16	15.7	7
K37-135	135	150	14	13.7	7
K37-135/1	135	160	14	13.7	7
K37-140	140	160	12	11.7	7
K37-140/1	140	155	13	12.7	7
K37-140/2	140	160	14.5	14.2	7
K37-140/3	140	160	12.5	12.2	7
K37-140/4	140	170	22.8	22.5	7
K37-145	145	157.7	10	9.7	7
K37-150	150	170	14	13.7	7
K37-150/1	150	170	14.5	14.2	7
K37-160	160	175	16	15.7	7
K37-160/1	160	180	14.5	14.2	7
K37-175	175	200	23	22.7	7
K37-180	180	200	14.5	14.2	7
K37-180/1	180	210	20.5	20.2	7
K37-190	190	210	14.5	14.2	7
K37-198	198	208	12	11.7	7
K37-200	200	220	14.5	14.2	10
K37-210	210	240	22.5	22.2	10
K37-220	220	250	20.5	20.2	10
K37-230	230	260	20.5	20.2	10



20 horizontal light gray lines for writing.



K38 is a single acting rod seal with symmetrical lips and an additional sealing lip which improves the leakage behaviour and at the same time, prevents the entry of dirt from the wiper side.

PRODUCT ADVANTAGES

- Superior sealing effect with the secondary lip
- Low axial housing heights
- Secondary sealing lip provides extra protection against the ingress of dirt particles
- Easy assembly into closed grooves
- Good sealing performance even at low pressures
- Wide range of dimensions

APPLICATION

Construction machinery, fork-lift trucks, injection moulding machines, agricultural machinery, mobile hydraulics, standard cylinders, loading platforms and telescopic cylinders.

MATERIAL	CODE
PU	94 SHORE A PU9401

OPERATING CONDITIONS			
MEDIA	Mineral oil (DIN 51524)	HFA and HFB	HFC
TEMPERATURE	-30°C +100°C	+5°C +50°C	-30°C +40°C
PRESSURE	≤400 Bar	≤400 Bar	≤400 Bar
SPEED	≤0.5 m/sec	≤0.5 m/sec	≤0.5 m/sec

Note: The above data are maximum values and cannot be used at the same time.

SURFACE ROUGHNESS		Ra	Rmax
Sliding Surface	Ød	≤0.4 µm	≤3.2 µm
Groove Base	ØD	≤1.6 µm	≤10 µm
Groove Flanks	B	≤3.2 µm	≤16 µm

Note: It is recommended to have 50% to 90% of the working surface material contact area value

INSTALLATION

Easily assembled into closed grooves according to the minimum diameter values that are given in the below table. Open grooves or special assembly tools should be used for the values that are outside this table. Before installation the sealing element must be oiled with system oil.

MINIMUM DIAMETER VALUES FOR CLOSED TYPE OF GROOVES							
(D-d)/2 (mm)	4	5	6	7.7	10	12.5	15
d min (mm)	25	30	40	50	80	100	105

NOTES

The permissible sealing gap values of K38 rod seal is given in the below table.

PERMISSIBLE SEALING GAP			
	Smax (mm)		
t=(D-d)/2 (mm)	150 Bar	250 Bar	400 Bar
t≤5	0.30	0.20	0.15
t>5	0.35	0.25	0.20

Note: The largest sealing gap value occurring on the non-pressurized side of the seal does have a vital importance for the function of the seal and in this respect it is quite important to use the S value lower than the above indicated numbers.

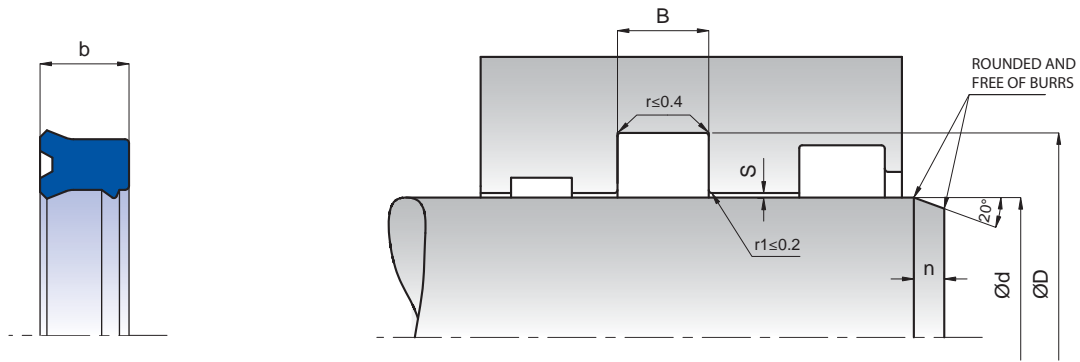

KASTAŞ NO	d (f8)	D (H10)	B (-0/+0.2)	b	n
K38-006	6	14	6.3	5.8	4
K38-008	8	16	6.3	5.8	4
K38-010	10	18	6.3	5.8	4
K38-012	12	19	6.3	5.7	3.5
K38-012/1	12	20	6.3	5.8	4
K38-014	14	22	6.3	5.8	4
K38-015	15	21.5	4.7	4.2	3
K38-016	16	24	6.3	5.8	4
K38-016/1	16	22	4.5	4	3
K38-018	18	26	6.3	5.8	4
K38-018/1	18	26	9	8	4
K38-018/2	18	25	5.5	5	3.5
K38-020	20	27	6.3	5.8	3.5
K38-020/1	20	28	6.3	5.8	4
K38-020/2	20	30	8	7	4.5
K38-022	22	28	5	4.5	3
K38-022/1	22	30	6.3	5.8	4
K38-022/2	22	30	8	7	4
K38-022/3	22	32	9	8	4.5
K38-022/5	22.22	28.57	7.35	6.35	3
K38-024	24.5	30	5	4.5	3
K38-025	25	33	6.3	5.8	4
K38-025/1	25	33	8	7	4
K38-025/2	25	35	8	7	4.5
K38-025/3	25	35	11	10	4.5
K38-028	28	38	6.3	5.8	4.5
K38-028/1	28	38	8	7	4.5
K38-028/3	28	36	6.3	5.8	4
K38-028/2	28	36	7.3	6.3	4
K38-030	30	38	6.3	5.8	4
K38-030/1	30	38	9	8	4
K38-030/2	30	36	7	6	3
K38-030/3	30	40	7.5	6.5	4.5
K38-030/4	30	40	11	10	4.5
K38-031	31.75	38.1	7.35	6.35	3
K38-032	32	40	9	8	4
K38-032/1	32	42	8	7	4.5
K38-032/3	32	40	7.5	6.5	4
K38-032/2	32	40	8	7	4
K38-034	34	50	11	10	6
K38-035	35	43	6.3	5.8	4
K38-035/1	35	43	9	8	4
K38-035/2	35	45	11	10	4.5
K38-035/3	35	50	11	10	5.5
K38-036	36	44	6.3	5.8	4
K38-036/1	36	44	9	8	4
K38-038	38	50	9.5	8.5	5
K38-038/1	38.1	47.62	8.92	7.92	4
K38-040	40	48	6.3	5.8	4

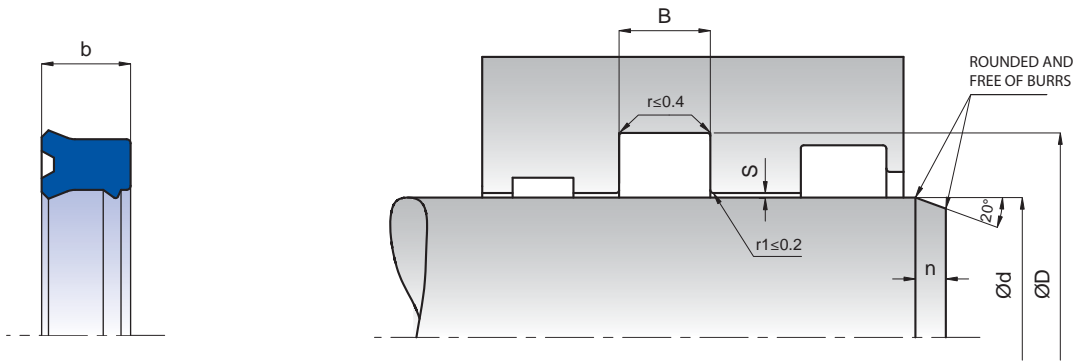

KASTAŞ NO	d (f8)	D (H10)	B (-0/+0.2)	b	n
K38-040/1	40	48	9	8	4
K38-040/2	40	50	8	7	4.5
K38-040/3	40	50	11	10	4.5
K38-040/4	40	55	11	10	5.5
K38-040/5	40	60	11	10	6
K38-040/7	40	48	7	6	4
K38-040/6	40	50	9	8	4.5
K38-042	42	50	7	6	4
K38-042/1	42	52	9	8	4.5
K38-044	44.45	53.97	8.92	7.92	4
K38-045	45	53	6.3	5.8	4
K38-045/1	45	55	6.3	5.8	4.5
K38-045/2	45	55	8	7	4.5
K38-045/3	45	55	11	10	4.5
K38-045/4	45	52	13	12	3.5
K38-046	46	54	9	8	4
K38-048	48	60	7	6	5
K38-050	50	58	9	8	4
K38-050/1	50	60	8	7	4.5
K38-050/2	50	60	10	9	4.5
K38-050/3	50	60	11	10	4.5
K38-050/4	50	65	11	10	5.5
K38-050/5	50	70	14.5	13.5	6
K38-050/6	50.8	60.32	8.92	7.92	4
K38-055	55	63	9	8	4
K38-055/1	55	65	11	10	4.5
K38-055/2	55	65	13	12	4.5
K38-055/3	55	65	9	8	4.5
K38-056	56	66	7.5	6.5	4.5
K38-056/1	56	71	12.5	11.5	5.5
K38-056/2	56	64	9	8	4
K38-060	60	68	9	8	4
K38-060/1	60	70	8.5	7.5	4.5
K38-060/2	60	70	11	10	4.5
K38-060/3	60	70	12.5	11.5	4.5
K38-060/4	60	72	10	9	5
K38-060/5	60	68	13	12	4
K38-060/6	60	70	8	7	4.5
K38-061	61	69	9	8	4
K38-063	63	71	9	8	4
K38-063/1	63.5	73.02	10.52	9.52	4
K38-065	65	73	9	8	4
K38-065/1	65	75	13.5	12.5	4.5
K38-070	70	78	9	8	4
K38-070/1	70	80	13	12	4.5
K38-070/2	70	85	12.5	11.5	5.5
K38-070/3	70	82	10	9	5
K38-075	75	83	9	8	4
K38-075/1	75	85	9	8	4.5

KASTAŞ NO	d (f8)	D (H10)	B (-0/+0.2)	b	n
K38-076	76	84	9	8	4
K38-076/1	76.2	85.72	10.52	9.52	4
K38-078	78	86	13	12	4
K38-080	80	88	9	8	4
K38-080/1	80	90	11	10	4.5
K38-080/2	80	90	13	12	4.5
K38-080/3	80	95	12.5	11.5	5.5
K38-080/4	80	96	10.5	9.5	6
K38-080/5	80	92	10	9	5
K38-085	85	93	9	8	4
K38-085/1	85	95	13	12	4.5
K38-086	86	101	13	12	5.5
K38-088	88	96	9	8	4
K38-090	90	98	9	8	4
K38-090/1	90	102	10	9	5
K38-090/2	90	105	12.5	11.5	5.5
K38-090/3	90	110	15	14	6
K38-091	91	99	9	8	4
K38-095	95	103	9	8	4
K38-095/1	95	105	9	8	4.5
K38-097	97	105	14	13	4
K38-097/1	97	105	13	12	4
K38-100	100	108	12.5	11.5	4
K38-100/1	100	115	13	12	5.5
K38-100/2	100	120	16	15	6
K38-105	105	113	9	8	4
K38-106	106	116	9	8	4.5
K38-107	107	115	9	8	4
K38-108	108	116	9	8	4
K38-110	110	130	16	15	6
K38-110/1	110	125	10.5	9.5	5.5
K38-112	112	127	13	12	5.5
K38-115	115	123	9	8	4
K38-115/1	115	125	9	8	4.5
K38-118	118	126	14	13	4
K38-120	120	128	12.5	11.5	4
K38-120/1	120	135	16	15	5.5
K38-125	125	145	16	15	6
K38-135	135	143	12.5	11.5	4
K38-135/1	135	145	9	8	4.5
K38-145	145	153	9	8	4
K38-155	155	163	12.5	11.5	4
K38-160	160	170	9	8	4.5
K38-180	180	190	12	11	4.5
K38-185	185	195	9	8	4.5
K38-210	210	220	12	11	4.5
K38-212	212	223	9	8	5

Please contact our customer service for the dimensions out of our stock list.



K96 is a single acting rod seal designed to have special geometry and inner lip shorter than the outer lip.

PRODUCT ADVANTAGES

- Superior static and dynamic sealing effect
- Easy assembly into closed grooves
- Able to work on hard conditions
- Very good static tightness due to the geometry
- Can go up to a pressure of 250 bar with using a back-up ring

APPLICATION

Construction machinery, fork-lift trucks and standard cylinders.

MATERIAL	CODE	
NBR	90 SHORE A	NB9001

OPERATING CONDITIONS			
MEDIA	Mineral oils (DIN 51524)	HFA and HFB	HFC
TEMPERATURE	-30°C +105°C	+5°C +60°C	-30°C +60°C
PRESSURE	≤150 Bar	≤150 Bar	≤150 Bar
SPEED	≤0.5 m/sec	≤0.5 m/sec	≤0.5 m/sec

Note: The above data are maximum values and cannot be used at the same time.

SURFACE ROUGHNESS		Ra	Rmax
Sliding Surface	Ød	≤0.4 µm	≤3.2 µm
Groove Base	ØD	≤1.8 µm	≤10 µm
Groove Flanks	B	≤3 µm	≤16 µm

Note: It is recommended to have 50% to 90% of the working surface material contact area value

INSTALLATION

Easily assembled into closed grooves. It is very important that the assembly tools must be of soft material and have no sharp edges. Before installation the wiper must be oiled with system oil.

NOTES

K96 can be produced on requests in FKM material for special applications that requires high temperatures. It is generally used with 2mm PTFE back-up rings in construction machinery. The permissible sealing gap values of K96 rod seal is given in the below table.

PERMISSIBLE SEALING GAP			
	Smax (mm)		
t=(D-d)/2	50 Bar	100 Bar	150 Bar
t≤5	0.40	0.20	0.10
t>5	0.45	0.25	0.15

Note: The largest sealing gap value occurring on the non-pressurized side of the seal does have a vital importance for the function of the seal and in this respect it is quite important to use the S value lower than the above indicated numbers.

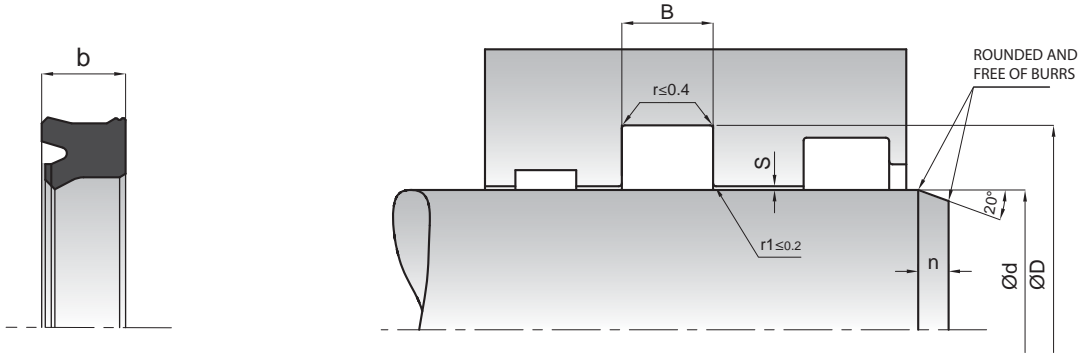

KASTAŞ NO	d (f8)	D (H11)	B (-0/+0.2)	b	n
K96-040	40	50	8	7	4.5
K96-045	45	55	8	7	4.5
K96-050	50	63	11	10	5
K96-055	55	68	11	10	5
K96-065	65	78	11	10	5
K96-070	70	83	11	10	5
K96-075	75	88	11	10	5
K96-080	80	93	11	10	5
K96-085	85	100	11	10	5.5
K96-090	90	105	11	10	5.5
K96-095	95	110	11.5	10.5	5.5
K96-100	100	115	11	10	5.5
K96-110	110	130	11	10	6
K96-120	120	140	11	10	6
K96-140	140	160	13	12	6
K96-140/1	140	160	11	10	6
K96-180	180	200	13	12	6



K701 is a two piece single acting rod seal which consists of a PTFE u-ring with metal spring as a tension component.

PRODUCT ADVANTAGES

- Superior static and dynamic sealing effect by the metal spring
- High resistance to chemicals and temperature changes
- Low friction, free of stick-slip
- High sliding speed
- Long service life
- Good dry running conditions
- Can be sterilized
- Low static and dynamic friction values

APPLICATION

Hydraulic and pneumatic cylinders, hot water valves, pumps, hot steam valves, food processing, chemical and medical technology.

MATERIAL	CODE
PTFE	PT6002
STAINLESS STEEL SPRING	CN9902

OPERATING CONDITIONS	
MEDIA	Hydraulic oils, hot air, water, steam, all media that do not react PTFE and stainless steel
TEMPERATURE	-150°C +250°C
PRESSURE	≤350 Bar
SPEED	≤15.0 m/sec

Note: The above data are maximum values and cannot be used at the same time.

SURFACE ROUGHNESS		Ra	Rmax
Sliding Surface	Ød	≤0.2 µm	≤2.0 µm
Groove Base	ØD	≤1.6 µm	≤6.3 µm
Groove Flanks	B	≤3.2 µm	≤15 µm

Note: It is recommended to have 50% to 90% of the working surface material contact area value. If the operating media is gas we recommend having Ra value not to be above 0.15 µm.

INSTALLATION

K701 is can be assembled into open and closed grooves. It is very important that the installation tools must be of soft material and have no sharp edges. Before installation the sealing element must be oiled with system oil.

NOTES

Depending on the PTFE material application values and their resistance can change. The permissible sealing gap values of K701 spring loaded rod seal is given in the below table.

PERMISSIBLE SEALING GAP				
B (mm)	Smax (mm)			
	50 Bar	150 Bar	250 Bar	350 Bar
2.4-3.6	0.10	0.075	0.05	0.05
4.8	0.20	0.10	0.075	0.06
7.1	0.25	0.15	0.10	0.075
9.5	0.30	0.15	0.13	0.075

Note: The largest sealing gap value occurring on the non-pressurized side of the seal does have a vital importance for the function of the seal and in this respect it is quite important to use the S value lower than the above indicated numbers.

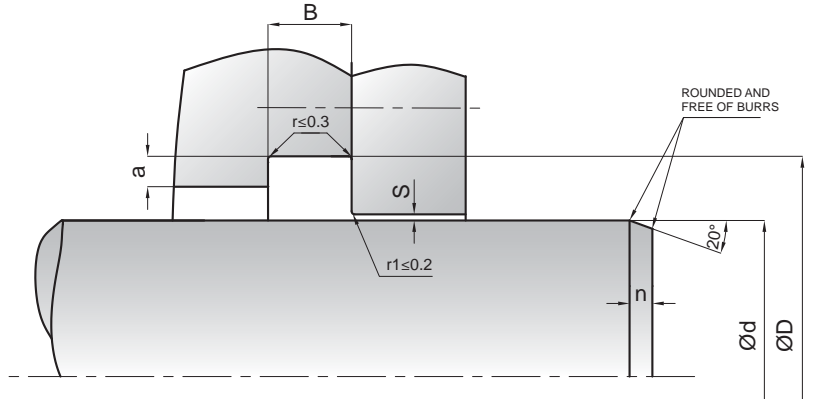
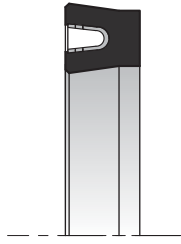
K701**SPRING LOADED ROD SEAL**

KASTAŞ NO	d (f8)	D (H9)	B (-0/+0.2)	a min.	n
K701-007	7	9.9	2.4	0.4	1.8
K701-012	12	16.5	3.6	0.6	2.8
K701-018	18	24.2	4.8	0.7	3.8
K701-020	20	26.2	4.8	0.7	3.8
K701-030	30	36.2	4.8	0.7	3.8
K701-035	35	41.2	4.8	0.7	3.8
K701-040	40	49.4	7.1	0.8	5.6
K701-050	50	59.4	7.1	0.8	5.6
K701-060	60	69.4	7.1	0.8	5.6
K701-070	70	79.4	7.1	0.8	5.6
K701-080	80	89.4	7.1	0.8	5.6
K701-090	90	99.4	7.1	0.8	5.6
K701-100	100	109.4	7.1	0.8	5.6
K701-110	110	119.4	7.1	0.8	5.6
K701-120	120	132.2	9.5	0.8	7.6

Please contact our customer service for the dimensions out of our stock list.



20 horizontal light gray lines for writing.

HYDRAULIC PISTON SEALING ELEMENTS





20 horizontal light gray lines for writing.

KASTAŞ CODE	PRODUCT NAME	DRAWING	APPLICATION	MATERIAL	CODE	PRESSURE (max) bar	TEMPERATURE (max) °C	SLIDING SPEED (max) - m/sn	PAGE NO
K03	Piston Packing		Piston	FABRIC NBR POM	NB8008 PM9903	400	-30/+105	0.5	114
K15	Piston Seal		Piston	NBR PU	NB7001 PU9501	250	-30/+100	0.5	116
K16	Compact Piston Seal		Piston	NBR FABRIC NBR POM	NB8001 NB8008 PM9901	400	-30/+105	0.5	118
K17	Piston Seal		Piston	NBR PTFE	NB7001 PT6003	400	-30/+105	5.0	120
K18	Compact Piston Seal		Piston	NBR TPE POM	NB8001 TP7301 PM9901	400	-30/+105	0.5	124
K19	Heavy Duty Piston Seal		Piston	NBR PTFE POM	NB8001 PT6003 PM9901	400	-30/+105	1.50	130
K20	Compact Piston Seal		Piston	NBR POM	NB8001 PM9901	150	-30/+105	0.5	132
K23	Piston Seal		Piston	NBR PU	NB9001 PU9201	150 400	-30/+105 -30/+100	0.5 0.5	134
K26	Piston Seal		Piston	NBR STEEL SPRING	NB9001 FE9901 CN9901	60	-30/+105	0.5	140
K40	Piston Seal		Piston	PU POM	PU9401 PM9901	400	-30/+100	0.5	142
K41	Piston Seal		Piston	NBR PTFE	NB7001 PT6003	400	-30/+105	5.0	144
K42	Compact Piston Seal		Piston	NBR TPE POM	NB8001 TP5501 PM9901	700	-30/+105	0.5	146
K43	Piston Seal		Piston	NBR POM	NB8001 BEZLÍ NBR PM9901	500 NB8008	-30/+105	0.5	148
K751	Spring Loaded Piston Seal		Piston	PTFE V-SPRING	PT6002 CN9902	350	-150/+250	15.0	150
K753	Piston Seal		Piston	NBR PTFE	NB7001 PT6003	400	-30/+105	2.0	152



K03 is a three piece single acting sealing set which consists of one reinforced cotton fabric backup ring, one elastomeric nitrile rubber middle ring, and one thermoplastic header ring.

PRODUCT ADVANTAGES

- Functions well even with poor surfaces
- Easy installation
- Adjustable seal housing height due to the reason of being used in open grooves.

APPLICATION

Used especially in hard working conditions such as iron and steel industry, mining equipment, marine hydraulics, scrap cutters and special cylinders where the actual conditions are difficult to predict.

MATERIAL	CODE
COTTON FABRIC NBR	NB8008
POM	PM9903

OPERATING CONDITIONS			
MEDIA	Mineral oil (DIN 51524)	HFA and HFB	HFC
TEMPERATURE	-30°C +105°C	+5°C +60°C	-30°C +60°C
PRESSURE	≤400 Bar	≤400 Bar	≤400 Bar
SPEED	≤0.5 m/sec	≤0.5 m/sec	≤0.5 m/sec

Note: The above data are maximum values and cannot be used at the same time.

SURFACE ROUGHNESS		Ra	Rmax
Sliding Surface	Ød	≤0.3 µm	≤2.5 µm
Groove Base	ØD	≤1.6 µm	≤6.3 µm
Groove Flanks	B	≤3.2 µm	≤16 µm

Note: It is recommended to have 50% to 90% of the working surface material contact area value

INSTALLATION

Suitable for open piston housing. When strongly squeezed, the flexibility of the sealing set may be substantially reduced. This could cause by excessive friction force, high wear and vibrated operating under low pressures. It is very important that the assembly tools must be of soft material and have no sharp edges. Before installation all individual parts of the seal must be oiled with system oil.

NOTES

For special applications that require high temperatures, our seal set can be manufactured with reinforced cotton fabric with FKM and special mixture of PTFE backup ring. Additional middle rings can be used depending on the application.

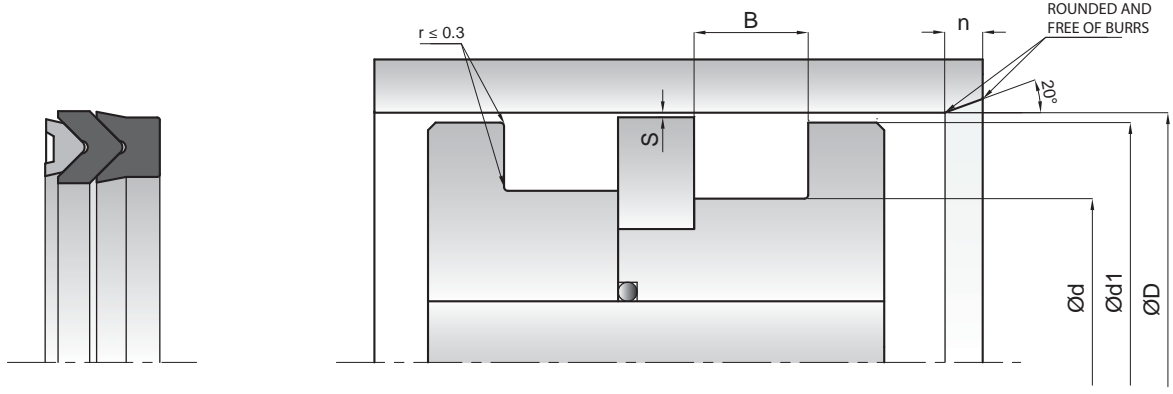

KASTAŞ NO	D (H9)	d (h11)	B (-0/+0.2)	d1 (-0.3/+0)	n
K03-020	20	10	9.3	19.5	6
K03-022	22	12	9.3	21.5	6
K03-025	25	15	9.3	24.5	6
K03-028	28	18	9.3	27.5	6
K03-030	30	20	9.3	29.5	6
K03-032	32	20	10.9	31	6
K03-035	35	23	10.9	34	6
K03-036	36	24	10.9	35	6
K03-040	40	25	11.5	39	6
K03-042	42	27	11.5	41	6
K03-045	45	30	11.5	44	6
K03-050	50	35	11.5	49	6
K03-055	55	40	11.5	54	6
K03-056	56	41	11.5	55	6
K03-060	60	45	11.5	59	6
K03-063	63	48	13	62	6
K03-070	70	50	15.2	69	7
K03-080	80	60	15.2	79	7
K03-090	90	70	21.2	89	7
K03-100	100	80	21.2	99	7
K03-110	110	90	21.2	109	7
K03-115	115	95	21.2	114	7
K03-125	125	100	25.8	124	8
K03-140	140	115	25.8	139	8
K03-150	150	120	29	148.5	8
K03-160	160	130	29	158.5	8
K03-180	180	150	31.5	178.5	8
K03-200	200	170	33.5	198.5	8
K03-250	250	220	33.5	248.5	8
K03-275	275	245	33.5	274.5	8
K03-300	300	270	33.5	299.5	8

Please contact our customer service for the dimensions out of our stock list.



K15 is a two piece double acting sealing set which consists of a special designed polyurethane seal ring and an o-ring as energizing element.

PRODUCT ADVANTAGES

- High static and dynamic sealing effect
- Low axial housing heights
- Simple groove design, one-piece piston possible
- High abrasion resistance

APPLICATION

Light to medium duty industrial machinery, injection moulding machines, cranes and loading platforms.

MATERIAL	CODE	
NBR	70 SHORE A	NB7001
PU	95 SHORE A	PU9501

OPERATING CONDITIONS

MEDIA	Mineral oils (DIN 51524)	HFA and HFB	HFC
TEMPERATURE	-30°C +100°C	+5°C +50°C	-30°C +40°C
PRESSURE	≤250 Bar	≤250 Bar	≤250 Bar
SPEED	≤0.5 m/sec	≤0.5 m/sec	≤0.5 m/sec

Note: The above data are maximum values and cannot be used at the same time.

ROUGHNESS SURFACE		Ra	Rmax
Sliding Surface	∅D	≤0.4 μm	≤3.2 μm
Groove Base	∅d	≤1.6 μm	≤6.3 μm
Groove Flanks	B	≤3.2 μm	≤16 μm

Note: It is recommended to have 50% to 90% of the working surface material contact area value.

INSTALLATION

Easily assembled on one-piece piston. It is very important that the assembly tools must be of soft material and have no sharp edges. Before installation the sealing element must be oiled with system oil.

NOTES

It is recommended to use with two piston guide rings in long stroke cylinders, one guide ring in short stroke and under low radial loads. The permissible sealing gap values of K15 piston seal is given in the below table.

PERMISSIBLE SEALING GAP	
B (mm)	Smax (mm)
3.2	0.25
4.2	0.25
6.3	0.3
8.1	0.3

Note: The largest sealing gap value occurring on the non-pressurized side of the seal does have a vital importance for the function of the seal and in this respect it is quite important to use the S value lower than the above indicated numbers.

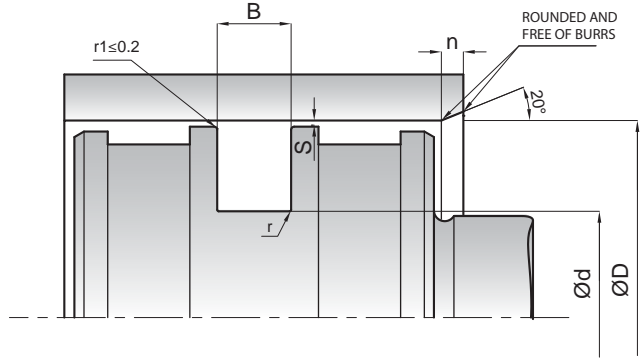
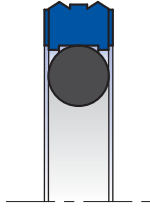

KASTAŞ NO	D (H9)	d (h9)	B (-0/+0.2)	r	n	O-Ring
K15 016-008.5	16	8.5	3.2	0.6	3	7.60x2.62
K15 025-014	25	14	4.2	1	4	13.87x3.53
K15 030-022.5	30	22.5	3.2	0.6	3	21.89x2.62
K15 032-021	32	21	4.2	1	4	20.22x3.53
K15 032-024.5	32	24.5	3.2	0.6	3	23.81x2.62
K15 035-027.5	35	27.5	3.2	0.6	3	26.64x2.62
K15 038-030.5	38	30.5	3.2	0.6	3	29.82x2.62
K15 040-029	40	29	4.2	1	4	28.17x3.53
K15 050-039	50	39	4.2	1	4	37.69x3.53
K15 055-039.5	55	39.5	6.3	1.3	5	37.47x5.33
K15 060-049	60	49	4.2	1	4	47.63x3.53
K15 063-052	63	52	4.2	1	4	50.80x3.53
K15 065-054	65	54	4.2	1	4	52.39x3.53
K15 070-059	70	59	4.2	1	4	57.15x3.53
K15 080-064.5	80	64.5	6.3	1.3	5	62.87x5.33
K15 080-069	80	69	4.2	1	4	68.26x3.53
K15 090-074.5	90	74.5	6.3	1.3	5	72.40x5.33
K15 100-084.5	100	84.5	6.3	1.3	5	81.92x5.33
K15 110-094.5	110	94.5	6.3	1.3	5	94.62x5.33
K15 115-094	115	94	8.1	1.3	7	92x7
K15 120-104.5	120	104.5	6.3	1.3	5	104.14x5.33
K15 125-109.5	125	109.5	6.3	1.3	5	107.32x5.33
K15 130-114.5	130	114.5	6.3	1.3	5	113.67x5.33

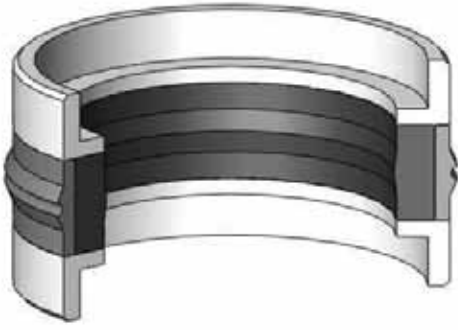

K16 is a three piece double acting compact seal which consists of one fabric reinforced elastomeric sealing element and two thermoplastic guide back-up rings.

PRODUCT ADVANTAGES

- Low friction, free of stick-slip
- Improved abrasion resistance
- Good dynamic and static sealing
- Long service life

APPLICATION

Mining equipment, iron and steel industry, marine hydraulics and earth moving equipment.

MATERIAL		CODE
NBR	80 SHORE A	NB8001
COTTON FABRIC NBR		NB8008
POM		PM9901

OPERATING CONDITIONS			
MEDIA	Mineral oils (DIN 51524)	HFA and HFB	HFC
TEMPERATURE	-30°C +105°C	+5°C +60°C	-30°C +60°C
PRESSURE	≤400 Bar	≤400 Bar	≤400 Bar
SPEED	≤0.5 m/sec	≤0.5 m/sec	≤0.5 m/sec

Note: The above data are maximum values and cannot be used at the same time.

SURFACE ROUGHNESS		Ra	Rmax
Sliding Surface	ØD	≤0.4 µm	≤3.2 µm
Groove Base	Ød	≤1.6 µm	≤6.3 µm
Groove Flanks	B	≤3.2 µm	≤16 µm

Note: It is recommended to have 50% to 90% of the working surface material contact area value

INSTALLATION

K16 profile has been designed to be installed in a closed or open grooves taking the indicated catalogue information into consideration. We recommend having open groove design for dimensions that are smaller than Ø 50 mm. It is very important that the assembly tools must be of soft material and have no sharp edges. Before installation the sealing element must be oiled with system oil.

NOTES

For special applications that require high temperatures, our seal set is being manufactured with reinforced cotton fabric with FKM and special mixture of PTFE guide back-up rings.

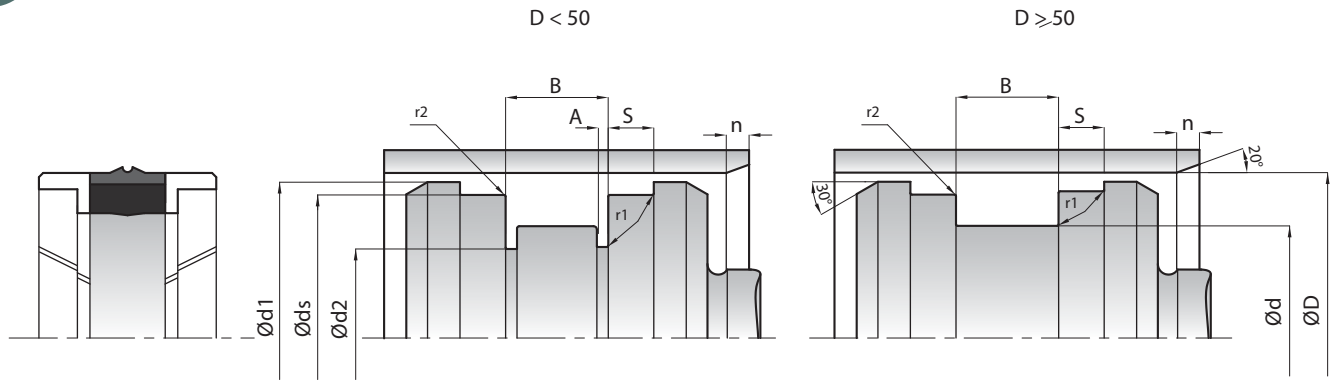

KASTAŞ NO	D (H11)	d (h11)	B (-0/+0.2)	ds (h8)	d1 (±0.1)	d2 (-0.1/+0)	A (-0/+0.1)	s (-0/+0.2)	r1	r2	n
K16 025-017	25	17	13.5	21	24.4	14	2.1	3.2	0.4	0.2	4
K16 030-022	30	22	13.5	26	29.4	19	2.1	3.2	0.4	0.2	4
K16 030-021	30	21	13.5	27	29.4	21	2.2	2.1	0.4	0.2	4
K16 032-024	32	24	15.5	28	31.4	21	3.1	3.2	0.4	0.2	4
K16 035-027	35	27	15.5	31	34.4	24	3.1	3.2	0.4	0.2	4
K16 040-032	40	32	15.5	36	39.4	29	3.1	3.2	0.4	0.2	4
K16 045-037	45	37	15.5	41	44.4	34	3.1	3.2	0.4	0.2	4
K16 050-038	50	38	20.5	46	49.4	-	-	4.2	0.4	0.2	4
K16 060-048	60	48	20.5	56	59.4	-	-	4.2	0.4	0.2	4
K16 063-051	63	51	20.5	59	62.4	-	-	4.2	0.4	0.2	4
K16 070-058	70	58	20.5	66	69.4	-	-	4.2	0.4	0.2	4
K16 075-063	75	63	20.5	71	69.4	-	-	4.2	0.4	0.2	4
K16 080-065	80	65	20	76	78.5	-	-	5	0.4	0.2	5
K16 080-066	80	66	22.5	76	79.4	-	-	5.2	0.4	0.2	4.5
K16 085-071	85	71	22.5	81	84.4	-	-	5.2	0.4	0.2	4.5
K16 090-076	90	76	22.5	86	89.4	-	-	5.2	0.4	0.2	4.5
K16 100-086	100	86	22.5	96	99.4	-	-	5.2	0.4	0.2	4.5
K16 110-096	110	96	22.5	106	109.4	-	-	5.2	0.4	0.2	4.5
K16 115-101	115	101	22.5	111	114.4	-	-	5.2	0.4	0.2	4.5
K16 120-106	120	106	22.5	116	119.4	-	-	5.2	0.4	0.2	4.5
K16 125-103	125	103	26.5	121	124.4	-	-	5.2	0.4	0.2	6
K16 125-108	125	108	26.5	121	124.4	-	-	7.2	0.4	0.2	5
K16 140-123	140	123	26.5	136	139.4	-	-	7.2	0.4	0.2	5
K16 150-133	150	133	26.5	146	149.4	-	-	7.2	0.4	0.2	5
K16 160-140	160	140	25	156	158	-	-	6.3	0.4	0.2	6
K16 160-143	160	143	26.5	156	159.4	-	-	7.2	0.4	0.2	5
K16 180-163	180	163	26.5	176	179.4	-	-	7.2	0.4	0.2	5
K16 200-180	200	180	31.5	196	199.4	-	-	9.2	0.4	0.2	6
K16 220-200	220	200	31.5	216	219.4	-	-	9.2	0.4	0.2	6
K16 250-225	250	225	31.5	246	249.4	-	-	6.6	0.4	0.2	6
K16 250-230	250	230	31.5	246	249.4	-	-	9.2	0.4	0.2	6



K17 is a two piece double acting piston seal which consists of one special mixture PTFE profile ring and an o-ring as energizing element.

PRODUCT ADVANTAGES

- Low friction, free of stick-slip
- Simple groove design and low axial housing heights
- Long service life
- High sliding speed
- Wide range of temperature and chemicals depending on the o-ring material
- Minimum static and dynamic friction coefficient for a minimum energy loss and operating temperature
- Wide range of dimensions

APPLICATION

Injection moulding machines, fork-lift trucks, loading platforms, cranes, agricultural machinery and valves for hydraulic and pneumatic systems.

MATERIAL		CODE
NBR	70 SHORE A	NB7001
PTFE		PT6003

OPERATING CONDITIONS

MEDIA	Mineral oils (DIN 51524)	HFA and HFB	HFC
TEMPERATURE	-30°C +105°C	+5°C +60°C	-30°C +60°C
PRESSURE	≤400 Bar	≤400 Bar	≤400 Bar
SPEED	≤5.0 m/sec	≤5.0 m/sec	≤5.0 m/sec

Note: The above data are maximum values and cannot be used at the same time.

SURFACE ROUGHNESS		Ra	Rmax
Sliding Surface	ØD	≤0.2 µm	≤2.0 µm
Groove Base	Ød	≤1.6 µm	≤6.3 µm
Groove Flanks	B	≤3.2 µm	≤15 µm

Note: It is recommended to have 50% to 90% of the working surface material contact area value.

INSTALLATION

We recommend using special assembly tool (See section; Hydraulic Sealing Elements General Installation Information) and to have open groove design for dimensions that are smaller than Ø 40 mm. It is very important that the assembly tools must be of soft material and have no sharp edges. Before installation the sealing element must be oiled with system oil.

NOTES

It is recommended to use with minimum two piston guide rings in long stroke cylinders, minimum one guide ring in short stroke and under low radial loads. For special applications that require high temperatures or resistance to chemicals, piston seal is being manufactured with special mixture PTFE and FKM material. The permissible sealing gap values of K17 piston seal is given in the below table.

PERMISSIBLE SEALING GAP

B (mm)	Smax (mm)		
	150 Bar	250 Bar	400 Bar
2.2	0.3	0.20	0.15
3.2	0.4	0.25	0.15
4.2	0.4	0.25	0.20
6.3	0.5	0.30	0.20
8.1	0.6	0.35	0.25
9.5	0.7	0.50	0.30

Note: The largest sealing gap value occurring on the non-pressurized side of the seal does have a vital importance for the function of the seal and in this respect it is quite important to use the S value lower than the above indicated numbers.

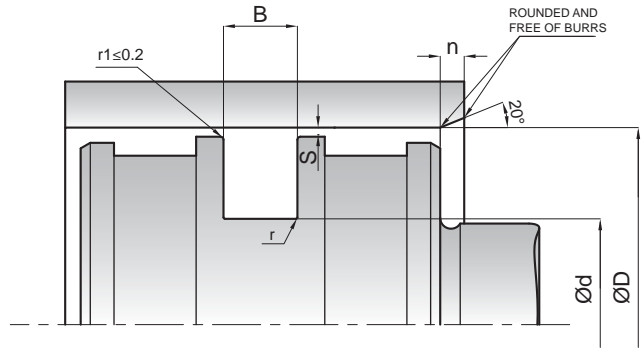
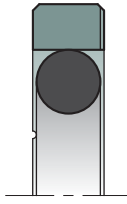

KASTAŞ NO	D (H8)	d (h9)	B (-0/+0.2)	r	n	O-Ring
K17 010-005.1	10	5.1	2.2	0.4	3	4.76x1.78
K17 012-007.1	12	7.1	2.2	0.4	3	6.75x1.78
K17 015-007.5	15	7.5	3.2	0.6	4.5	7.59x2.62
K17 016-008.5	16	8.5	3.2	0.6	4.5	7.59x2.62
K17 020-012.5	20	12.5	3.2	0.6	4.5	12.37x2.62
K17 025-014	25	14	4.2	1	6	13.87x3.53
K17 025-017.5	25	17.5	3.2	0.6	4.5	17.12x2.62
K17 032-021	32	21	4.2	1	6	20.22x3.53
K17 032-024.5	32	24.5	3.2	0.6	4.5	23.47x2.62
K17 035-030.1	35	30.1	2.2	0.4	3	29.87x1.78
K17 035-027.5	35	27.5	3.2	0.6	4.5	26.64x2.62
K17 040-032.5	40	32.5	3.2	0.6	6	31.42x2.62
K17 040-029	40	29	4.2	1	6	28.17x3.53
K17 040-024.5	40	24.5	6.3	1.3	8	23.17x5.33
K17 045-034	45	34	4.2	1	6	32.92x3.53
K17 048-037	48	37	4.2	1	6	36.10x3.53
K17 050-039	50	39	4.2	1	6	37.69x3.53
K17 055-044	55	44	4.2	1	6	44.04x3.53
K17 060-044.5	60	44.5	6.3	1.3	8	43.82x5.33
K17 060-049	60	49	4.2	1	6	47.22x3.53
K17 063-052	63	52	4.2	1	6	50.39x3.53
K17 063-047.5	63	47.5	6.3	1.3	8	47x5.33
K17 063-055.5	63	55.5	3.2	0.6	4.5	55.25x2.62
K17 065-049.5	65	49.5	6.3	1.3	8	48.50x5.33
K17 065-054	65	54	4.2	1	6	53.57x3.53
K17 068-057	68	57	4.2	1	6	56.74x3.53
K17 070-054.5	70	54.5	6.3	1.3	8	53.34x5.33
K17 070-059	70	59	4.2	1	6	56.74x3.53
K17 075-064	75	64	4.2	1	6	63.09x3.53
K17 075-059.5	75	59.5	6.3	1.3	8	56.52x5.33
K17 080-059	80	59	8.1	1.8	10.5	58x6.99
K17 080-064.5	80	64.5	6.3	1.3	8	62.87x5.33
K17 080-069	80	69	4.2	1	6	66.27x3.53
K17 085-064	85	64	8.1	1.8	10.5	63x7
K17 085-074	85	74	4.2	1	6	73.03x3.53
K17 085-069.5	85	69.5	6.3	1.3	8	69.22x5.33
K17 090-074.5	90	74.5	6.3	1.3	8	72.40x5.33
K17 090-069	90	69	8.1	1.8	10.5	68.20x6.99
K17 095-079.5	95	79.5	6.3	1.3	8	78.74x5.33
K17 100-079	100	79	8.1	1.8	10.5	77x7
K17 100-089	100	89	4.2	1	6	88.50x3.53
K17 100-084.5	100	84.5	6.3	1.3	8	81.92x5.33
K17 105-089.5	105	89.5	6.3	1.3	8	88.27x5.33
K17 110-089	110	89	8.1	1.8	10.5	88x6.99
K17 110-099	110	99	4.2	1	6	98.02x3.53
K17 110-094.5	110	94.5	6.3	1.3	8	91.44x5.33
K17 115-094	115	94	8.1	1.8	10.5	92x7
K17 115-099.5	115	99.5	6.3	1.3	8	97.79x5.33
K17 120-104.5	120	104.5	6.3	1.3	8	100.97x5.33

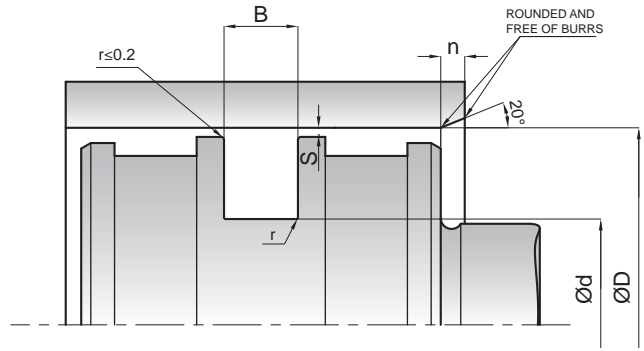
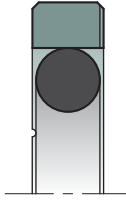

KASTAŞ NO	D (H8)	d (h9)	B (-0/+0.2)	r	n	O-Ring
K17 120-099	120	99	8.1	1.8	10.5	97x7
K17 125-104	125	104	8.1	1.8	10.5	102x7
K17 125-114	125	114	4.2	1	6	113.90x3.53
K17 125-109.5	125	109.5	6.3	1.3	8	107.32x5.33
K17 130-109	130	109	8.1	1.8	10.5	107x7
K17 130-114.5	130	114.5	6.3	1.3	8	113.67x5.33
K17 140-119	140	119	8.1	1.8	10.5	116.84x6.99
K17 140-124.5	140	124.5	6.3	1.3	8	123.19x5.33
K17 140-129	140	129	4.2	1	6	126.60x3.53
K17 145-124	145	124	8.1	1.8	10.5	123.19x6.99
K17 150-129	150	129	8.1	1.8	10.5	126.37x6.99
K17 155-134	155	134	8.1	1.8	10.5	132.72x6.99
K17 160-139	160	139	8.1	1.8	10.5	135.89x6.99
K17 165-144	165	144	8.1	1.8	10.5	142.24x6.99
K17 170-149	170	149	8.1	1.8	10.5	148.59x6.99
K17 180-159	180	159	8.1	1.8	10.5	158.12x6.99
K17 185-164	185	164	8.1	1.8	10.5	161.90x6.99
K17 185-169.5	185	169.5	6.3	1.3	8	164.47x5.33
K17 190-169	190	169	8.1	1.8	10.5	164.47x6.99
K17 195-174	195	174	8.1	1.8	10.5	170.82x6.99
K17 200-179	200	179	8.1	1.8	10.5	177.17x6.99
K17 200-184.5	200	184.5	6.3	1.3	8	183.52x5.33
K17 205-184	205	184	8.1	1.8	10.5	183.52x6.99
K17 210-189	210	189	8.1	1.8	10.5	183.52x6.99
K17 215-194	215	194	8.1	1.8	10.5	189.87x6.99
K17 220-199	220	199	8.1	1.8	10.5	196.22x6.99
K17 225-204	225	204	8.1	1.8	10.5	202.57x6.99
K17 230-209	230	209	8.1	1.8	10.5	202.57x6.99
K17 240-219	240	219	8.1	1.8	10.5	215.27x6.99
K17 245-224	245	224	8.1	1.8	10.5	221.62x6.99
K17 250-229	250	229	8.1	1.8	10.5	227.97x6.99
K17 260-239	260	239	8.1	1.8	10.5	234.32x6.99
K17 265-244	265	244	8.1	1.8	10.5	240.67x6.99
K17 270-249	270	249	8.1	1.8	10.5	240.67x6.99
K17 275-254	275	254	8.1	1.8	10.5	247.00x6.99
K17 280-259	280	259	8.1	1.8	10.5	253.57x6.99
K17 300-279	300	279	8.1	1.8	10.5	278.77x6.99
K17 305-284	305	284	8.1	1.8	10.5	278.77x6.99
K17 310-289	310	289	8.1	1.8	10.5	278.77x6.99
K17 315-294	315	294	8.1	1.8	10.5	291.47x6.99
K17 320-295.5	320	295.5	8.1	1.8	12	291.47x6.99
K17 320-299	320	299	8.1	1.8	10.5	291.47x6.99
K17 325-304	325	304	8.1	1.8	10.5	297.88x6.99
K17 330-305.5	330	305.5	8.1	1.8	12	304.17x6.99
K17 340-315.5	340	315.5	8.1	1.8	12	316.87x6.99
K17 350-325.5	350	325.5	8.1	1.8	12	316.87x6.99
K17 360-335.5	360	335.5	8.1	1.8	12	329.57x6.99
K17 370-345.5	370	345.5	8.1	1.8	12	342.27x6.99
K17 380-355.5	380	355.5	8.1	1.8	12	354.90x6.99



K18 is a five piece double acting compact seal consisting of one elastomeric nitrile rubber sealing element, two polyester elastomer back-up rings on both sides to prevent extrusion into the sealing gap and two special profil guide rings made of thermoplastic to absorb transverse forces.

PRODUCT ADVANTAGES

- Superior sealing performance
- Economic sealing and guiding solution
- Simple groove design, one-piece piston possible
- Long service life
- Simple snap installation

APPLICATION

Construction machinery, fork-lift trucks, injection moulding machines, agricultural machinery, cranes and standard cylinders.

MATERIAL		CODE
NBR	80 SHORE A	NB8001
TPE		TP7301
POM		PM9901

OPERATING CONDITIONS			
MEDIA	Mineral oils (DIN 51524)	HFA and HFB	HFC
TEMPERATURE	-30°C +105°C	+5°C +60°C	-30°C +60°C
PRESSURE	≤400 Bar	≤400 Bar	≤400 Bar
SPEED	≤0.5 m/sec	≤0.5 m/sec	≤0.5 m/sec

Note: The above data are maximum values and cannot be used at the same time.

SURFACE ROUGHNESS		Ra	Rmax
Sliding Surface	∅D	≤0.4 μm	≤4.0 μm
Groove Base	∅d	≤1.6 μm	≤6.3 μm
Groove Flanks	B	≤3.2 μm	≤16 μm

Note: It is recommended to have 50% to 90% of the working surface material contact area value.

INSTALLATION

Easily assembled into one-piece piston because of the back-up rings and guide rings are being produced in split forms. It is very important that the assembly tools must be of soft material and have no sharp edges. Before installation the sealing element must be oiled with system oil.

NOTES

For special applications that require high temperatures, piston seal can be manufactured in FKM and PTFE material.

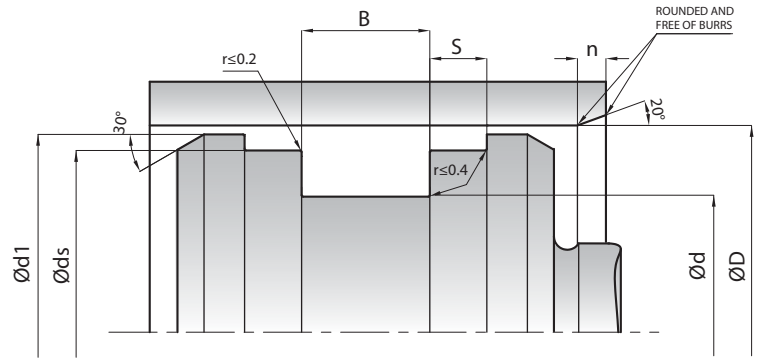
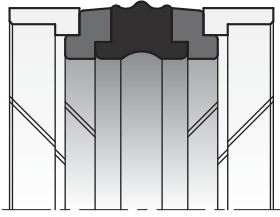

KASTAŞ NO	D (H8)	d (h9)	B (-0/+0.2)	ds (h8)	d1 (± 0.1)	s (-0/+0.2)	n
K18 020-011	20	11	13.5	17	19	2.1	4
K18 022-013	22	13	13.5	19	21	2.1	4
K18 025-015/1	25	15	12	21	23	4	4
K18 025-015/2	25	15	12.5	22	24	4	4
K18 025-015	25	15	16.4	21.45	23.5	6.35	4
K18 025-016	25	16	13.5	22	24	2.1	4
K18 025-017/2	25	17	10	22	24	4	4
K18 025-017/1	25	17	13.5	21	24.4	3.2	4
K18 028-019	28	19	13.5	25	27	2.1	4
K18 030-017	30	17	15.4	26.5	28.5	6.35	4
K18 030-021	30	21	13.5	27	29	2.1	4
K18 030-022	30	22	13.5	26	29.4	3.2	4
K18 032-022	32	22	16.4	28.5	30.5	6.35	4
K18 032-022/2	32	22	15.5	29	31	4	4
K18 032-022/1	32	22	15.5	28	31	2.6	4
K18 032-024	32	24	15.5	28	31	3.1	4
K18 032-024/1	32	24	10	29	31	4	4
K18 035-025	35	25	16.4	31.4	33.5	6.35	4
K18 035-027	35	27	15.5	31	34.4	3.2	4
K18 038.1-025.4	38.1	25.4	15.87	34.54	37.08	6.35	4
K18 040-024	40	24	18.4	35.4	38.5	6.35	5
K18 040-026	40	26	15.5	36	39	2.6	4.5
K18 040-030	40	30	16.4	35.4	38.5	6.35	4
K18 040-030/1	40	30	12.5	37	39	4	4
K18 040-032/1	40	32	10	37	39	4	4
K18 040-032	40	32	15.5	36	39.4	3.2	4
K18 042-028	42	28	15.5	38	41	2.6	4.5
K18 044.4-028.57	44.45	28.57	19.05	39.85	43.12	6.35	5
K18 045-029	45	29	18.4	40.4	43.5	6.35	5
K18 045-031	45	31	15.5	41	44	2.6	4.5
K18 045-035	45	35	16.4	40.4	43.5	6.35	4
K18 045-037	45	37	15.5	41	44.4	3.2	4
K18 050-034	50	34	20.5	46	49	3.1	5
K18 050-034/1	50	34	18.4	45.41	48.66	6.35	5
K18 050-035	50	35	20	46	48.5	5	5
K18 050-038	50	38	20.5	46	49.4	4.2	4
K18 050-040	50	40	12.5	47	49	4	4
K18 050.8-034.92	50.8	34.92	19.05	46.23	49.48	6.35	5
K18 050.8-041.27	50.8	41.27	11.1	46.27	49.19	3.81	4
K18 055-039	55	39	20.5	51	54	3.1	5
K18 055-039/1	55	39	18.4	50.37	53.65	6.35	5
K18 055-045	55	45	12.5	52	54	4	4
K18 056-040	56	40	20.5	52	55	3.1	5
K18 057.15-041.27	57.15	41.27	19.45	52.55	55.8	6.35	5
K18 060-044	60	44	20.5	56	59	3.1	5
K18 060-044/1	60	44	18.4	55.39	58.65	6.35	5
K18 060-048	60	48	20.5	56	59.4	4.2	4
K18 060.32-044.45	60.32	44.45	19.05	55.72	58.98	6.35	5
K18 063-047	63	47	20.5	59	62	3.1	5

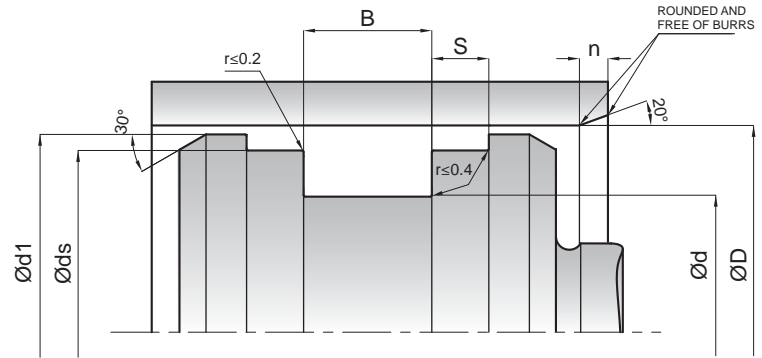
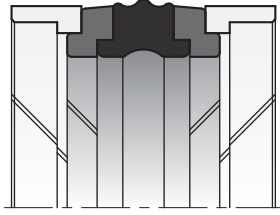

KASTAŞ NO	D (H8)	d (h9)	B (-0/+0.2)	ds (h8)	d1 (±0.1)	s (-0/+0.2)	n
K18 063-047/1	63	47	18.4	58.39	61.63	6.35	5
K18 063-047/2	63	47	19.4	58.4	61.5	6.35	5
K18 063-048	63	48	20	59	61.5	5	5
K18 063-051	63	51	20.5	59	62.4	4.2	4
K18 063-053	63	53	12.5	60	62	4	4
K18 063.5-047.62	63.5	47.62	19.05	58.9	62.12	6.35	5
K18 063.5-053.97	63.5	53.97	11.1	59.12	62.12	3.81	4
K18 063.5-53.97/1	63.5	53.97	11.1	58.92	61.9	3.81	4
K18 065-049	65	49	20.5	61	64	3.1	5
K18 065-050	65	50	18.4	60.41	63.64	6.35	5
K18 066.67-050.8	66.67	50.8	19.05	62.1	65.27	6.35	5
K18 067-051	67	51	18.4	62.4	65.6	6.35	5
K18 069.85-50.8	69.85	50.8	23.79	64.07	68.85	6.35	5
K18 070-050	70	50	22.4	64.18	68.34	6.35	6
K18 070-054	70	54	20.5	66	69	3.1	5
K18 070-055	70	55	20	66	68.5	5	5
K18 070-058	70	58	20.5	66	69.4	4.2	4
K18 075-055	75	55	22.4	69.2	73.3	6.35	6
K18 075-059	75	59	20.5	71	74	3.1	5
K18 076.2-057.15	76.2	57.15	23.8	70.38	74.5	6.35	5
K18 076,2-66,67	76.2	66.67	11.1	71.62	74.6	3.81	4
K18 076,2-60,32	76.2	60.32	19.05	70.96	74.16	6.35	5
K18 080-060	80	60	22.4	74.15	78.3	6.35	6
K18 080-060/1	80	60	35	72.62	77.54	9.52	6
K18 080-062	80	62	22.5	76	79	3.6	5
K18 080-060/2	80	60	25	75	78	6.35	6
K18 080-065	80	65	20	76	78.5	5	5
K18 080-066	80	66	22.4	76	79.4	5.2	4.5
K18 082.55-063.5	82.55	63.5	24.21	76.73	80.9	6.35	5
K18 085-065	85	65	22.4	79.15	83.3	6.35	6
K18 085-065/1	85	65	21.4	79.15	83.3	6.35	6
K18 085-075	85	75	20	81	83.35	4	4
K18 088.9-069.85	88.9	69.85	24.21	83.08	87.22	6.35	5
K18 088.9-76.2	88.9	76.2	14.27	82.93	87.3	5.33	4
K18 088.9-69.85/1	88.9	69.85	30.15	82.16	87.29	6.35	5
K18 090-070	90	70	22.4	84.15	88.3	6.35	6
K18 090-072	90	72	22.5	86	89	3.2	5
K18 090-072/1	90	72	22.5	86	89	3.6	5
K18 090-075	90	75	20	86	88.5	5	5
K18 090-076	90	76	22.4	86	89.4	5.2	4.5
K18 095-075	95	75	22.4	89.15	93.31	6.35	6
K18 095-081	95	81	22.4	91	94.4	5.2	4.5
K18 100-075	100	75	22.4	93.13	98	6.35	6
K18 100-080	100	80	25.4	95	98	6.35	6
K18 100-080/2	100	80	25	95	98	6.35	6
K18 100-080/1	100	80	35	92.61	97.51	9.52	6
K18 100-082	100	82	22.5	96	99	3.6	5
K18 100-085	100	85	20	96	98.5	5	5
K18 100-086	100	86	22.4	96	99.4	5.2	4.5

KASTAŞ NO	D (H8)	d (h9)	B (-/+0.2)	ds (h8)	d1 (±0.1)	s (-/+0.2)	n
K18 101.6-082.55	101.6	82.55	23.8	95.76	100.07	6.35	5
K18 105-080	105	80	22.4	98.1	103	6.5	6
K18 105-080/1	105	80	22.4	98.1	103	6.35	6
K18 107.95-088.9	107.95	88.9	23.8	102.08	106.23	6.35	5
K18 110-085	110	85	22.4	103.1	108	6.35	6
K18 110-085/1	110	85	25.4	103.1	108	6.35	6
K18 110-090	110	90	35	102.6	107.51	9.52	6
K18 110-090/1	110	90	25.3	104.1	108.3	6.4	6
K18 110-092	110	92	22.5	106	109	3.6	5
K18 110-095	110	95	20	105	108	5	5
K18 110-096	110	96	22.4	106	109.4	5.2	4.5
K18 114.3-088.9	114.3	88.9	31.75	107.42	112.33	6.35	6
K18 115-090	115	90	22.4	108.1	113.02	6.35	6
K18 115-097	115	97	22.4	111	114	4.2	5
K18 115-097/1	115	97	22.5	111	114	3.6	5
K18 115-101	115	101	22.4	111	114.4	5.2	4.5
K18 120-095	120	95	22.4	113.1	118	6.35	6
K18 120-100	120	100	35	112.8	117.5	9.5	6
K18 120-106	120	106	22.4	116	119.4	5.2	4.5
K18 125-100	125	100	25.4	118.1	123	6.35	6
K18 125-100/1	125	100	45	116.82	122.33	12.7	6
K18 125-103	125	103	26.5	121	124	5.1	6
K18 125-105/1	125	105	25	120	123	6.35	6
K18 125-105	125	105	25.4	120	123	6.35	6
K18 125-108	125	108	26.5	121	124.4	7.2	5
K18 127-101.6	127	101.6	32.15	120.09	124.98	9.52	6
K18 130-105	130	105	25.4	123.1	128	6.35	6
K18 130-105/1	130	105	25.4	123.1	128	9.52	6
K18 130-105/2	130	105	25.4	122.6	127.5	9.52	6
K18 133.35-107.5	133.35	107.95	31.75	126.42	131.3	6.35	6
K18 135-110	135	110	25.4	127.6	132.5	9.52	6
K18 135-110/1	135	110	25.4	128.1	133	6.35	6
K18 139.7-114.3	139.7	114.3	31.75	132.4	137.2	9.5	6
K18 139.7-114.3/1	139.7	114.3	31.75	132.4	137.2	6.5	6
K18 140-115	140	115	25.4	132.6	137.5	6.35	6
K18 140-115/1	140	115	25.4	132.6	137.5	9.52	6
K18 140-115/2	140	115	25.4	133	138	6.35	6
K18 140-115/4	140	115	45	131.7	137.36	12.7	6
K18 140-118	140	118	26.5	136	139	5.1	6
K18 140-120	140	120	25	135	138	6.35	6
K18 140-123	140	123	26.5	136	139.4	7.2	5
K18 145-120	145	120	25.4	137.6	142.5	9.52	6
K18 150-125	150	125	25.4	142.6	147.5	9.5	6
K18 150-125/1	150	125	25.4	143	148	6.35	6
K18 150-128	150	128	26.5	146	149	5.1	6
K18 150-130	150	130	25.4	144.1	148.3	6.35	6
K18 150-133	150	133	26.5	146	149.4	7.2	5
K18 152.4-127	152.4	127	31.75	145	149.91	9.52	6
K18 152.4-127/1	152.4	127	38.1	145.69	150.79	9.52	6
K18 155-130	155	130	25.4	148	153	6.35	6
K18 155-130/1	155	130	25.4	147.6	152.5	9.52	6
K18 160-130	160	130	25.4	153	157.5	6.35	6
K18 160-130/1	160	130	25.4	152.6	157.5	9.52	6
K18 160-130/2	160	130	25.4	153	157.5	9.52	6
K18 160-135	160	135	25.4	152.6	157.5	9.52	6
K18 160-135/1	160	135	45	151.72	157.1	12.7	6
K18 160-135/2	160	135	32	154	158	10	6
K18 160-138	160	138	26.5	156	159	5.1	6
K18 160-143	160	143	26.5	156	159.4	7.2	5
K18 160-140	160	140	25	155	158	6.35	6
K18 165-140	165	140	25.4	157.6	162.5	9.52	6
K18 165.1-139.7	165.1	139.7	31.9	157.82	162.6	6.45	6
K18 170-145	170	145	25.4	161.72	167.1	12.7	6
K18 170-148	170	148	26.5	166	169	5.1	6
K18 177.8-152.4	177.8	152.4	31.75	170.51	175.52	9.52	6

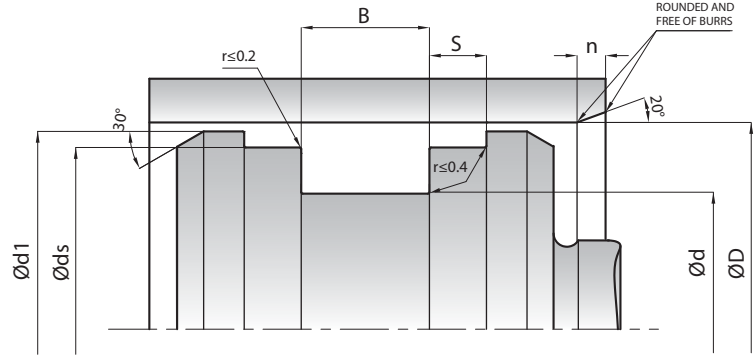
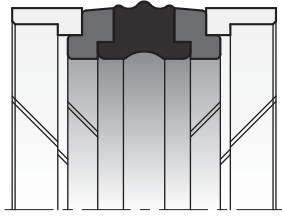

KASTAŞ NO	D (H8)	d (h9)	B (-0/+0.2)	ds (h8)	d1 (±0.1)	s (-0/+0.2)	n
K18 177.8-152.4/1	177.8	152.4	31.75	170.52	175.52	6.45	6
K18 180-150	180	150	35.4	172.95	177.87	6.35	6
K18 180-150/1	180	150	36	172	177.87	12.5	6
K18 180-155	180	155	25.4	171.72	177.1	12.7	6
K18 180-158	180	158	26.5	176	179	5.1	6
K18 180-163	180	163	26.5	176	179.4	7.2	5
K18 185-160	185	160	25.4	176.72	182.1	12.7	6
K18 190-165	190	165	25.4	181.72	187.05	12.7	6
K18 195-170	195	170	25.4	187.1	192.05	12.7	6
K18 200-170	200	170	35.4	193	198	6.35	6
K18 200-170/1	200	170	36	192	197	12.5	6
K18 200-175	200	175	31.5	196	199	6.6	6
K18 200-175/1	200	175	25.4	191.62	197	12.7	6
K18 200-180	200	180	31.5	196	199.4	9.2	6
K18 203.2-171.45	203.2	171.45	38.1	195.09	201.17	8	6
K18 203.2-177.8	203.2	177.8	31.75	196.16	201.18	9.52	6
K18 210-185	210	185	25.4	201.62	207	12.7	6
K18 220-190	220	190	35.4	212.7	217.9	6.35	6
K18 220-190/1	220	190	35.4	213.5	217.9	6.35	6
K18 220-195	220	195	25.4	211.62	217	12.7	6
K18 220-200	220	200	31.5	216	219.4	9.2	6
K18 225-200	225	200	31.5	221	224	6.6	6
K18 230-205	230	205	25.4	221.62	227	12.7	6
K18 240-215	240	215	25.4	231.62	237	12.7	6
K18 250-220	250	220	35.4	242.9	247.85	6.35	6
K18 250-225	250	225	25.4	241.62	247	12.7	6
K18 250-230	250	230	31.5	246	249.4	9.2	6
K18 280-250	280	250	36.4	273	278	10	6
K18 280-250/1	280	250	35.4	272.9	277.85	9.52	6



Lined writing area consisting of 25 horizontal light gray lines.



K19 is a four piece double acting heavy duty compact seal which consists of one PTFE bronze profile ring, one elastomeric nitrile rubber pre-load sealing element and two thermoplastic back-up rings.

PRODUCT ADVANTAGES

- High sliding speed
- Low friction, free of stick-slip
- Simple groove design
- Long service life
- Very good sealing performance even with pressure peaks
- High resistance to abrasion
- Increased clearance possible

APPLICATION

Mining equipment, construction machinery and earth moving equipment.

MATERIAL		CODE
NBR	80 SHORE A	NB8001
PTFE		PT6003
POM		PM9901

OPERATING CONDITIONS

MEDIA	Mineral oils (DIN 51524)	HFA and HFB	HFC
TEMPERATURE	-30°C +105°C	+5°C +60°C	-30°C +60°C
PRESSURE	≤400 Bar	≤400 Bar	≤400 Bar
SPEED	≤1.5 m/sec	≤1.5 m/sec	≤1.5 m/sec

Note: The above data are maximum values and cannot be used at the same time.

SURFACE ROUGHNESS		Ra	Rmax
Sliding Surface	∅D	≤0.2 μm	≤2.0 μm
Groove Base	∅d	≤1.6 μm	≤6.3 μm
Groove Flanks	B	≤3.2 μm	≤15 μm

Note: It is recommended to have 50% to 90% of the working surface material contact area value.

INSTALLATION

The elastomeric ring should be assembled into the one-piece piston firstly, and then special mixture PTFE should be assembled with a special assembly tool (See section; Hydraulic Sealing Elements General Installation Information) finally the split guide rings should be installed. The required insertion chamfers on the piston and cylinder bore should be de-burred and rounded. It is very important that the assembly tools must be of soft material and have no sharp edges. Before installation the sealing element must be oiled with system oil.

NOTES

For special applications that require high temperatures, piston seal can be manufactured with FKM pre-load component, pure PTFE back-up rings and special mixture PTFE profile ring. Thanks to the design, K19 can be used up to shock pressures of 600 bar safely. The permissible sealing gap values of K19 heavy duty piston seal is given in the below table.

PERMISSIBLE SEALING GAP	
PRESSURE (Bar)	Smax (mm)
P≤350	0.45
350<P≤600	0.25

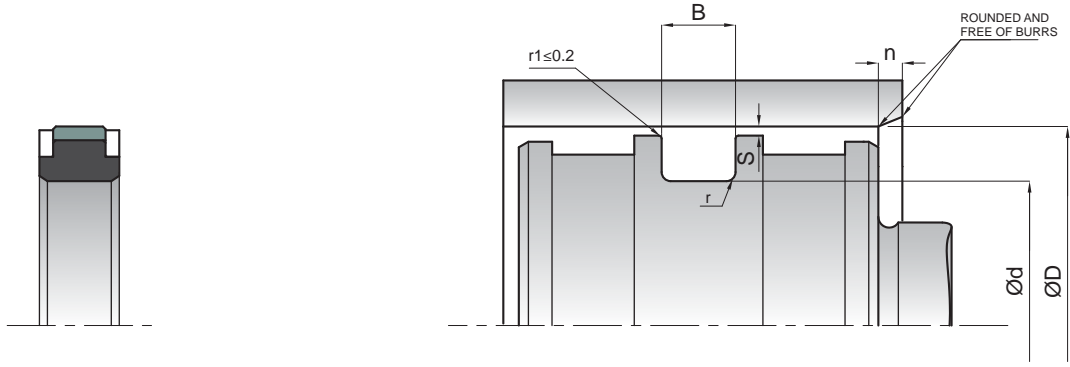

KASTAŞ NO	D (H8)	d (h9)	B (-0/+0.2)	r	n
K19 050-036	50	36	9	0.3	6.5
K19 055-041	55	41	9	0.3	6.5
K19 060-046	60	46	9	0.3	6.5
K19 060-050	60	50	8	0.3	5
K19 063-048	63	48	11	0.5	7.5
K19 065-050	65	50	11	0.5	7.5
K19 070-055	70	55	11	0.5	7.5
K19 075-060	75	60	11	0.5	7.5
K19 080-065	80	65	11	0.5	7.5
K19 085-070	85	70	11	0.5	7.5
K19 090-075	90	75	11	0.5	7.5
K19 095-080	95	80	11	0.5	7.5
K19 100-085	100	85	12.5	0.5	7.5
K19 105-090	105	90	12.5	0.5	7.5
K19 105-090/1	105	90	13.5	0.5	7.5
K19 110-095	110	95	12.5	0.5	7.5
K19 115-100	115	100	12.5	0.5	7.5
K19 120-105	120	105	12.5	0.6	7.5
K19 125-102	125	102	16	0.6	11.5
K19 130-107	130	107	16	0.6	11.5
K19 135-112	135	112	16	0.6	11.5
K19 140-117	140	117	16	0.6	11.5
K19 145-122	145	122	16	0.6	11.5
K19 150-127	150	127	16	0.6	11.5
K19 150-130	150	130	18	0.6	10.5
K19 150-135	150	135	12.5	0.6	7.5
K19 160-137	160	137	16	0.6	11.5
K19 165-142	165	142	15.5	0.6	11.5
K19 165-145	165	145	17	0.6	10.5
K19 170-147	170	147	16	0.6	11.5
K19 170-155	170	155	16	0.6	7.5
K19 180-157	180	157	16	0.6	11.5
K19 180-160	180	160	18	0.6	10.5
K19 200-177	200	177	16	0.6	11.5
K19 290-270	290	270	16	0.6	10.5



K20 is a three piece double acting compact seal which consists one elastomeric nitrile rubber sealing element and two special profil thermoplastic guide rings.

PRODUCT ADVANTAGES

- Simple groove design, one-piece piston possible
- Simple snap installation
- Economic sealing and guiding solution
- Can be used in small cross-sections

APPLICATION

Agricultural machinery and light duty cylinders.

MATERIAL		CODE
NBR	80 SHORE A	NB8001
POM		PM9901

OPERATING CONDITIONS			
MEDIA	Mineral oils (DIN 51524)	HFA and HFB	HFC
TEMPERATURE	-30°C +105°C	+5°C +60°C	-30°C +60°C
PRESSURE	≤150 Bar	≤150 Bar	≤150 Bar
SPEED	≤0.5 m/sec	≤0.5 m/sec	≤0.5 m/sec

Note: The above data are maximum values and cannot be used at the same time.

SURFACE ROUGHNESS		Ra	Rmax
Sliding Surface	∅D	≤0.4 μm	≤4.0 μm
Groove Base	∅d	≤1.6 μm	≤10 μm
Groove Flanks	B	≤3.2 μm	≤16 μm

Note: It is recommended to have 50% to 90% of the working surface material contact area value.

INSTALLATION

Easily assembled into one-piece piston because of the guide rings being in split forms. It is very important that the assembly tools must be of soft material and have no sharp edges. Before installation the sealing elements must be oiled with system oil.

NOTES

For special applications that require high temperatures, piston seal can also be manufactured in FKM and special mixture PTFE material.

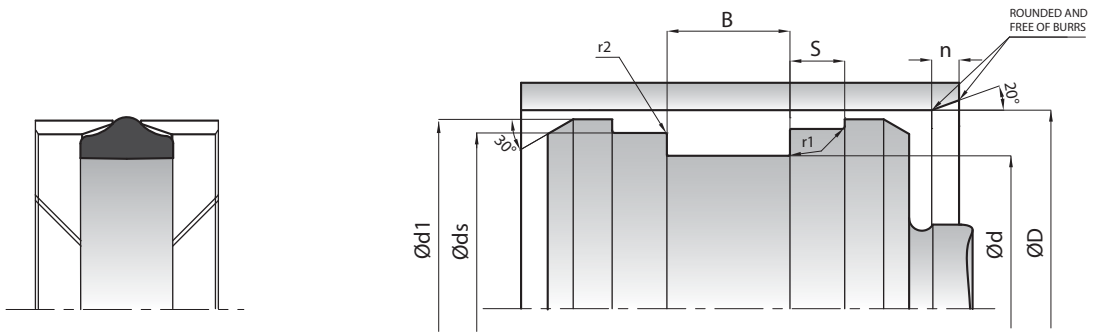

KASTAŞ NO	D (H10)	d (h9)	d1 (h11)	ds (h9)	B (-0/+0.2)	S (-0/+0.1)	n	r1	r2
K20 025-017.50	25	17.5	24	21.3	8.7	3.2	2	0.4	0.2
K20 025.4-017.45	25.43	17.45	23.83	21.08	8.9	3.05	2	0.4	0.2
K20 031.75-023.80	31.79	23.83	30.18	27.44	8.9	3.05	2	0.4	0.2
K20 032-022	32	22	31	27.5	11.2	3.9	2.5	0.4	0.2
K20 038.1-028.57	38.14	28.61	36.54	33.67	11.3	3.7	2.5	0.4	0.2
K20 040-030	40	30	39	35.5	11.2	3.9	2.5	0.4	0.2
K20 044.45-034.92	44.5	34.96	42.9	40.02	11.30	3.7	2.5	0.4	0.2
K20 050-040	50	40	49	45.5	11.2	3.9	2.5	0.4	0.2
K20 050.8-041.27	50.86	41.32	49.26	46.38	11.3	3.7	2.5	0.4	0.2
K20 057.15-047.62	57.21	47.68	55.61	52.76	11.3	3.7	2.5	0.4	0.2
K20 063-053	63	53	61.5	58.5	11.2	3.9	2.5	0.4	0.2
K20 063.50-053.97	63.57	54.04	61.97	59.12	11.3	3.7	2.5	0.4	0.2
K20 069.85-060.32	69.93	60.39	68.33	65.48	11.3	3.7	2.5	0.4	0.2
K20 076.20-066.67	76.29	66.75	74.68	71.84	11.3	3.7	2.5	0.4	0.2
K20 080-070	80	70	78.5	75.5	11.2	3.9	2.5	0.4	0.2
K20 082.55-073.02	82.64	73.11	81.04	78.19	11.3	3.7	2.5	0.4	0.2
K20 088.9-076.20	89	76.29	87.4	83.15	14.45	5.21	3.2	0.4	0.2
K20 092-082	92	82	90.5	87.5	11.2	3.9	2.5	0.4	0.2
K20 095.25-082.55	95.36	82.64	93.76	89.51	14.45	5.21	3.2	0.4	0.2
K20 100-087	100	87	98.5	93.8	14.2	5.9	4	0.4	0.2
K20 101.6-088.9	101.71	89	100.11	95.87	14.45	5.21	3.2	0.4	0.2
K20 114.3-101.6	114.43	101.71	112.83	108.58	14.45	5.21	3.2	0.4	0.2
K20 125-112	125	112	123.5	118.8	14.20	5.9	4	0.4	0.2
K20 127-111.12	127.14	111.25	125.54	119.23	17.65	8.65	4	0.8	0.41
K20 140-124	140	124	138.5	132	17.70	8.70	5	0.8	0.4
K20 152.4-133.35	152.57	133.5	150.97	145.25	25.55	12.6	4.8	0.8	0.41
K20 160-140	160	140	158.5	151.4	25.20	12.4	5	0.8	0.4
K20 180-160	180	160	178.5	171.4	25.20	12.4	5	0.8	0.4
K20 200-180	200	180	198.5	191.4	25.20	12.4	5	0.8	0.4



K23 is a single acting piston seal designed to have outer lip shorter than the inner lip in order to be used for piston applications.

PRODUCT ADVANTAGES

- Superior static and dynamic sealing effect
- Wide range of dimensions
- Easy assembly into closed grooves
- Simple groove design
- Economical sealing solution

APPLICATION

Construction machinery, fork-lift trucks, injection moulding machines, agricultural machinery, loading platforms and standard cylinders.

MATERIAL		CODE
NBR	90 SHORE A	NB9001
PU	92 SHORE A	PU9201

OPERATING CONDITIONS			
NBR			
MEDIA	Mineral oils (DIN 51524)	HFA and HFB	HFC
TEMPERATURE	-30°C +105°C	+5°C +60°C	-30°C +60°C
PRESSURE	≤150 Bar	≤150 Bar	≤150 Bar
SPEED	≤0.5 m/sec	≤0.5 m/sec	≤0.5 m/sec

PU			
MEDIA	Mineral oils (DIN 51524)	HFA and HFB	HFC
TEMPERATURE	-30°C +100°C	+5°C +50°C	-30°C +40°C
PRESSURE	≤400 Bar	≤400 Bar	≤400 Bar
SPEED	≤0.5 m/sec	≤0.5 m/sec	≤0.5 m/sec

Note: The above data are maximum values and cannot be used at the same time.

SURFACE ROUGHNESS		Ra	Rmax
Sliding Surface	∅D	≤0.4 μm	≤3.2 μm
Groove Base	∅d	≤1.6 μm	≤10 μm
Groove Flanks	B	≤3.2 μm	≤16 μm

Note: It is recommended to have 50% to 90% of the working surface material contact area value

INSTALLATION

Easily assembled into closed grooves according to the minimum diameter values that are given in the below table. Open grooves or special installation tools should be used for the values that are outside this table. It is very important that the assembly tools must be of soft material and have no sharp edges. Before installation the sealing element must be oiled with system oil.

MINIMUM DIAMETER VALUES FOR CLOSED TYPE OF GROOVES							
(D-d)/2 (mm)	4	5	6	7.7	10	12.5	15
D min	25	30	40	50	80	100	105

NOTES

For special applications that require high temperatures, K23 can be produced in FKM material. The permissible sealing gap values of K23 piston seal is given in the below table.

PERMISSIBLE SEALING GAP			
NBR	Smax (mm)		
t=(D-d)/2 (mm)	50 Bar	100 Bar	150 Bar
t≤5	0.40	0.20	0.10
t>5	0.45	0.25	0.15

PU	Smax (mm)		
t=(D-d)/2 (mm)	150 Bar	250 Bar	400 Bar
t≤5	0.30	0.20	0.15
t>5	0.35	0.25	0.20

Note: The largest sealing gap value occurring on the non-pressurized side of the seal does have a vital importance for the function of the seal and in this respect it is quite important to use the S value lower than the above indicated numbers.

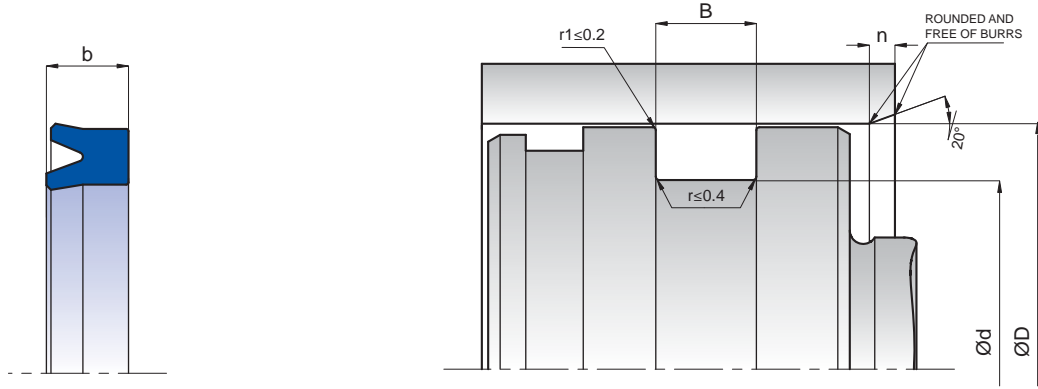

KASTAŞ NO	NBR	PU	D (H11)	d (h11)	b	B (-0/+0.2)	n
K23-009	NBR		9	4	3.5	4	2.5
K23-012/1	NBR	PU	12	4.5	4	4.5	4
K23-012	NBR		12	7	2.55	3.05	2.5
K23-012/2	NBR	PU	12.7	6.35	4.76	5.26	3
K23-013		PU	13.8	8.6	2.8	3.3	2.5
K23-014/3		PU	14	6	6	7	4
K23-014	NBR	PU	14	6	8	9	4
K23-014/1	NBR	PU	14	8	4.5	5	3
K23-014/2	NBR		14.28	7.93	4.76	5.26	3
K23-015	NBR	PU	15	9	8	9	3
K23-016	NBR	PU	16	6	10	11	4.5
K23-016/5	NBR	PU	16	8	5.5	6.5	4
K23-016/3	NBR	PU	16	9	5.5	6.5	3.5
K23-016/1	NBR	PU	16	10	4	4.5	3
K23-016/2	NBR	PU	16	10	5.5	6.5	3
K23-016/4	NBR	PU	16	10	8	9	3
K23-017	NBR	PU	17.46	12.05	3.17	3.67	3
K23-019	NBR	PU	19.05	12.7	3.17	3.67	3
K23-020/3	NBR	PU	20	12	5.5	6.5	4
K23-020/2	NBR		20	14	2.7	3.2	3
K23-020/1	NBR	PU	20	14	4.2	4.7	3
K23-020	NBR	PU	20	14	5.5	6.5	3
K23-020/4	NBR	PU	20.63	14.28	6.35	7.35	3
K23-022/1	NBR	PU	22	10	8	9	5
K23-022	NBR	PU	22	13	7	8	4
K23-022/3	NBR	PU	22	16	5.5	6.5	3
K23-022/2	NBR	PU	22.22	12.7	6.35	7.35	4
K23-025/5	NBR	PU	25	15	5	6	4.5
K23-025/6	NBR	PU	25	17	5.5	6.5	4
K23-025/1	NBR	PU	25	18	5	6	3.5
K23-025/2	NBR	PU	25	19	3	3.5	3
K23-025/3	NBR	PU	25	19	6	7	3
K23-025/4	NBR		25.4	15.87	6.35	7.35	4
K23-026/2	NBR	PU	26	18	5.5	6.5	4
K23-026	NBR	PU	26	18	7	8	4
K23-026/3	NBR	PU	26.99	17.46	6.35	7.35	4
K23-028	NBR	PU	28	16	9	10	5
K23-028/1	NBR	PU	28.57	19.05	6.35	7.35	4
K23-030/2	NBR	PU	30	15	10	11	5.5
K23-030/1	NBR	PU	30	20	7	8	4.5
K23-030	NBR	PU	30	22	6	7	4
K23-031/1	NBR	PU	31.75	19.05	6.35	7.35	6
K23-031/2	NBR	PU	31.75	19.05	7.93	8.93	6
K23-032/2	NBR	PU	32	22	5	6	4.5
K23-032/1	NBR	PU	32	22	7	8	4.5
K23-032	NBR	PU	32	24	5.5	6.5	4
K23-034	NBR	PU	34.92	22.22	6.35	7.35	6
K23-035/4	NBR	PU	35	20	10	11	5.5
K23-035	NBR	PU	35	25	6.5	7.5	4.5

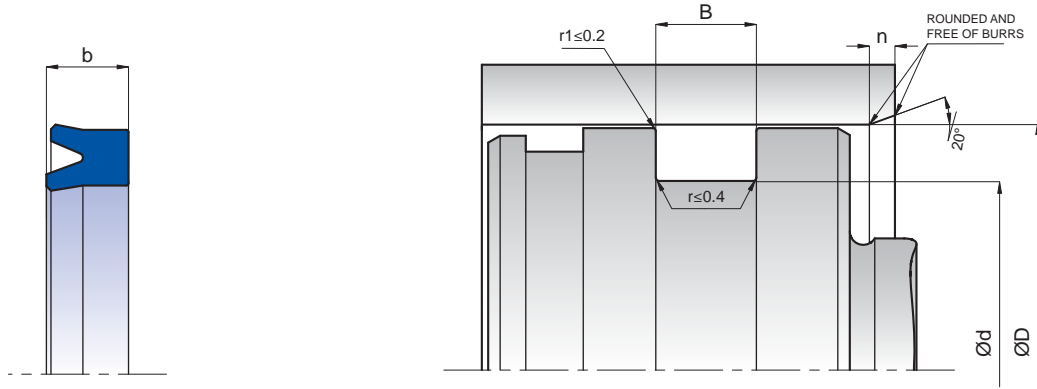

KASTAŞ NO	NBR	PU	D (H11)	d (h11)	b	B (-0/+0.2)	n
K23-035/1	NBR	PU	35	25	7	8	4.5
K23-035/3	NBR	PU	35	25	8	9	4.5
K23-035/2	NBR	PU	35	27	10	11	4
K23-036/2	NBR	PU	36	24	6	7	5
K23-036	NBR	PU	36	28	7	8	4
K23-036/3	NBR	PU	36.51	25.4	6.35	7.35	5
K23-038/1	NBR	PU	38	28	7	8	4.5
K23-038	NBR	PU	38.1	25.4	7.93	8.93	6
K23-039	NBR	PU	39	32	5	6	3.5
K23-039/2	NBR	PU	39.69	26.99	6.35	7.35	6
K23-040/5	NBR	PU	40	28	9	10	5
K23-040/4	NBR	PU	40	28	10	11	5
K23-040/6	NBR	PU	40	30	5	6	4.5
K23-040/3	NBR	PU	40	30	6	7	4.5
K23-040/2	NBR	PU	40	30	7	8	4.5
K23-040/8	NBR	PU	40	32	3.25	3.75	4
K23-040/7	NBR	PU	40	32	5.5	6	4
K23-041	NBR	PU	41.27	30.16	6.35	7.35	5
K23-042	NBR	PU	42.86	30.16	9.52	10.52	6
K23-043	NBR	PU	43	35	9	10	4
K23-043/1	NBR	PU	43	38	3.8	4.3	2.5
K23-044	NBR	PU	44.45	28.57	9.52	10.52	6
K23-044/1	NBR	PU	44.45	34.92	7	8	4
K23-045/2	NBR	PU	45	35	6	7	4.5
K23-045/1	NBR	PU	45	37	7	8	4
K23-045	NBR	PU	45	38	6	7	3.5
K23-047	NBR	PU	47.62	31.75	7.93	8.93	6
K23-049	NBR	PU	49.21	35.23	9.52	10.52	5.5
K23-050/5	NBR	PU	50	38	6	7	5
K23-050/4	NBR	PU	50	40	5	6	4.5
K23-050/3	NBR	PU	50	40	7	8	4.5
K23-050/6	NBR	PU	50	42	10	11	4
K23-050/7	NBR	PU	50.8	41.27	4.76	5.26	4
K23-050/9	NBR	PU	50.8	41.27	7.14	8.14	4
K23-052	NBR	PU	52	42	5	6	4.5
K23-053/1	NBR	PU	53.97	38.1	9.52	10.52	6
K23-053/2	NBR	PU	53.97	41.27	9.52	10.52	6
K23-055	NBR	PU	55	45	7	8	4.5
K23-055/2	NBR	PU	55	45	7.5	8.5	4.5
K23-055/1	NBR	PU	55	45	10	11	4.5
K23-056	NBR	PU	56	46	7	8	4.5
K23-057	NBR	PU	57.15	41.27	7.93	8.93	6
K23-057/1	NBR	PU	57.15	41.27	9.52	10.52	6
K23-057/2	NBR	PU	57.15	44.45	6.35	7.35	6
K23-060/1	NBR	PU	60	44	12	13	6
K23-060/3	NBR	PU	60	50	7	8	4.5
K23-060/4	NBR	PU	60	50	7.3	8.3	4.5
K23-060/2	NBR	PU	60	50	10	11	4.5
K23-060/5	NBR	PU	60.32	47.62	6.25	7.35	6

KASTAŞ NO	NBR	PU	D (H11)	d (h11)	b	B (-0/+0.2)	n
K23-062/1	NBR	PU	62	52	7	8	4.5
K23-063/4		PU	63	50	9	10	5
K23-063/2	NBR		63	50	10	11	5
K23-063/1	NBR	PU	63	53	4.25	4.75	4.5
K23-063	NBR	PU	63	53	6	7	4.5
K23-063/3	NBR		63	53	7	8	4.5
K23-063/6	NBR	PU	63.5	45.7	8.85	9.85	6
K23-063/7	NBR	PU	63.5	47.62	9.52	10.52	6
K23-063/5	NBR	PU	63.5	53.97	6.35	7.35	4
K23-065	NBR	PU	65	55	7	8	4.5
K23-066	NBR	PU	66.67	50.8	8.85	9.85	6
K23-069	NBR	PU	69.85	50.8	12.7	13.7	6
K23-069/1	NBR	PU	69.85	53.97	7.93	8.93	6
K23-070/1	NBR	PU	70	50	14	15	6
K23-070/2	NBR	PU	70	60	10	11	4.5
K23-070/3	NBR		70	58	8.5	9.5	5
K23-070/4	NBR	PU	70	62	8	9	4
K23-070/5	NBR		70	60	7	8	4.5
K23-073	NBR	PU	73.02	63.5	5.56	6.56	4
K23-075/1	NBR	PU	75	63	8.5	9.5	5
K23-075	NBR	PU	75	65	7.5	8.5	4.5
K23-076/2	NBR	PU	76.2	58.04	8.73	9.73	6
K23-079	NBR		79.37	66.67	6.35	7.35	6
K23-080/7	NBR		80	64	8	9	6
K23-080/10	NBR	PU	80	65	10	11	5.5
K23-080/3	NBR	PU	80	68	8.5	9.5	5
K23-080/9		PU	80	70	12	13	4.5
K23-080/6	NBR	PU	80	72	12	13	4
K23-082		PU	82	70	8	9	5
K23-083	NBR		83	71.9	7.5	8.5	5
K23-085	NBR		85	73	8.5	9.5	5
K23-085/1	NBR		85.72	73.02	9.52	10.52	6
K23-090	NBR		90	78	8.5	9.5	5
K23-092	NBR		92.07	76.2	9.52	10.52	6
K23-095		PU	95.25	76.2	9.52	10.52	6
K23-095/1	NBR		95.25	76.99	7.4	8.4	6
K23-098	NBR		98.42	85.72	9.52	10.52	6
K23-100/4	NBR		100	84	8	9	6
K23-100	NBR	PU	100	85	9	10	5.5
K23-100/7	NBR	PU	100	85	12	13	5.5
K23-100/3	NBR	PU	100	88	8.5	9.5	5
K23-100/9	NBR		100	90	4.3	4.8	4.5
K23-100/8	NBR	PU	100	90	6.5	7.5	4.5
K23-100/6	NBR	PU	100	90	7.2	8.2	4.5
K23-100/1	NBR	PU	100	90	8.5	9.5	4.5
K23-100/5		PU	100	90	10.5	11.5	4.5
K23-101/1	NBR		101.6	82.55	12.7	13.7	6
K23-101	NBR		101.6	88.9	9.52	10.52	6
K23-104	NBR		104.5	86.5	12	13	6
K23-105	NBR		105	94	8	9	5
K23-107	NBR		107.95	88.9	12.7	13.7	6
K23-110/1	NBR		110	90	15	16	6
K23-110	NBR	PU	110	95	10	11	5.5
K23-112		PU	112	98	9	10	5.
K23-114	NBR		114	103	5.85	6.85	5
K23-115		PU	115	100	6	7	5.5
K23-120	NBR		120	105	10	11	5.5
K23-123	NBR		123.82	111.12	9.52	10.52	6
K23-125	NBR	PU	125	105	12	13	6
K23-125/6	NBR	PU	125	105	15	16	6
K23-125/1	NBR		125	105	16	17	6
K23-125/3	NBR	PU	125	110	10	11	5.5
K23-125/5	NBR	PU	125	115	7.2	8.2	4.5
K23-127/1	NBR		127	101.6	15.87	16.87	7
K23-127		PU	127	113	10	11	5.5

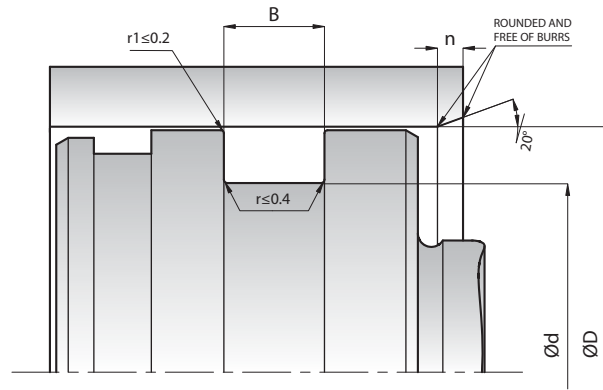
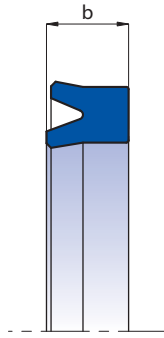

KASTAŞ NO	NBR	PU	D (H11)	d (h11)	b	B (-0/+0.2)	n
K23-130	NBR	PU	130	110	12	13	6
K23-130/1	NBR		130.17	117.5	9.52	10.52	6
K23-140/5	NBR		140	120	14	15	6
K23-140/2		PU	140	120	15	16	6
K23-140	NBR	PU	140	120	16	17	6
K23-140/3		PU	140	125	9	10	5.5
K23-140/4	NBR		140	125	10	11	5.5
K23-140/1		PU	140	125	15	16	5.5
K23-145	NBR	PU	145	130	10	11	5.5
K23-146	NBR		146.05	137.9	6.6	7.6	4
K23-149	NBR		149.22	136.52	9.52	10.52	6
K23-150	NBR	PU	150	135	8	9	5.5
K23-152/1		PU	152	130	10	11	7
K23-152		PU	152	130	15	16	7
K23-160	NBR	PU	160	140	14	15	6
K23-160/2		PU	160	145	9	10	5.5
K23-160/3	NBR		160	145	10	11	5.5
K23-160/1	NBR	PU	160	145	14	15	5.5
K23-170/1		PU	170	145	19	20	7
K23-170	NBR	PU	170	148	15	16	7
K23-175	NBR	PU	175	155	14	15	6
K23-180	NBR	PU	180	160	9	10	6
K23-180/3		PU	180	160	12	13	6
K23-180/1	NBR	PU	180	160	14	15	6
K23-180/2		PU	180	165	9	10	5.5
K23-190/1	NBR		190	170	14	15	6
K23-190	NBR		190.5	158.75	19.05	20.05	8
K23-200/3		PU	200	170	18	19	8
K23-200	NBR	PU	200	175	16	17	7
K23-200/1	NBR	PU	200	180	14	15	6
K23-220		PU	220	195	16	17	7
K23-220/1		PU	220	200	15	16	6
K23-222	NBR		222.25	190.5	19.05	20.05	8
K23-247	NBR		247.65	215.9	19.05	20.05	8
K23-250	NBR	PU	250	230	14	15	6
K23-250/2		PU	250	230	15	16	6
K23-250/1		PU	250	238	14	15	5
K23-260		PU	260	240	16	17	6
K23-280		PU	280	250	18	19	8
K23-300	NBR	PU	300	270	12	13	8
K23-300/1		PU	300	288	14	15	5
K23-320		PU	320	290	20	21	8
K23-330	NBR		330	310	12	13	6
K23-360	NBR		360	330	20	21	8
K23-450		PU	450	420	22	23	8



20 horizontal light gray lines for writing.



K26 is a double acting complete piston seal which consists of a steel plate vulcanized with elastomeric nitrile rubber using special production methods. The sealing lips have springs in order to increase the preload.

PRODUCT ADVANTAGES

- Good sealing performance at low pressures thanks to the spring loaded sealing lips
- Long service life
- Ready to fit complete piston
- Also used in pneumatic systems

APPLICATION

Short stroke, low pressure hydraulic cylinder and special pneumatic cylinders.

MATERIAL		CODE
NBR	90 SHORE A	NB9001
STEEL	ST37	FE9901
STAINLESS STEEL SPRING		CN9901

OPERATING CONDITIONS				
MEDIA	Mineral oils (DIN 51524)	HFA and HFB	HFC	Compressed Air
TEMPERATURE	-30°C +105°C	+5°C +60°C	-30°C +60°C	-30°C +105°C
PRESSURE	Diagram 1	Diagram 1	Diagram 1	16 Bar
SPEED	≤0.5 m/sec	≤0.5 m/sec	≤0.5 m/sec	≤0.5 m/sec

Note: The above data are maximum values and cannot be used at the same time.

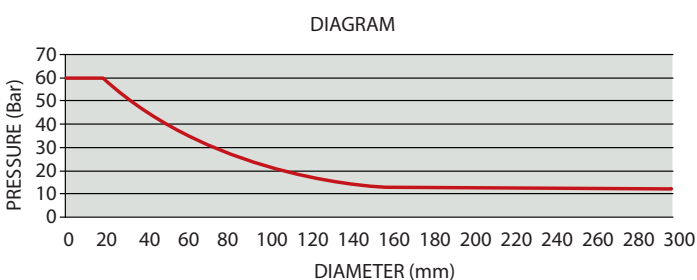

SURFACE ROUGHNESS

	Ra	Rmax
Sliding Surface	≤0.4 μm	≤4 μm

Note: It is recommended to have 50% to 90% of the working surface material contact area value.

INSTALLATION

K26 is pushed onto the piston rod with the rubber layer on the clamping flange towards the rod and fixed by fastening. The nut has to be secured. The sliding surface and the cylinder bore should be oiled with an oil that must not go into the reaction with the sealing element during the installation process. Special precautions has to be taken at the end of the strokes to avoid damaging of the sealing lips.

NOTES

For special applications that require high temperatures, K26 can also be produced in FKM.

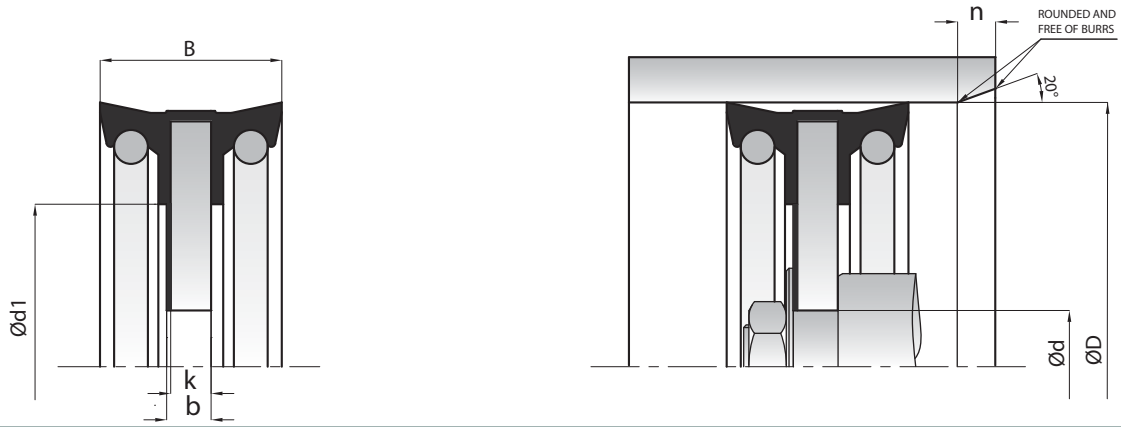

KASTAŞ NO	D (H11)	d (f9)	d1	B	b	k	n
K26-025	25	8	14	22	3.5	3	5
K26-026	26	8	15	22	3.5	3	5
K26-030	30	8	17.5	22	3.5	3	5
K26-032	32	8	18.5	25	3.5	3	5
K26-035	35	8	18.5	26	3.5	3	5
K26-038	38	8	20.5	25	3.5	3	5
K26-040	40	10	22.5	25	3.5	3	5
K26-045	45	10	23.5	25	4.5	4	5
K26-050	50	10	26.5	25	4.5	4	5
K26-055	55	10	31.5	25	4.5	4	5
K26-060	60	12	37	26	4.5	4	5
K26-063	63	12	42	25	4.5	4	5
K26-065	65	12	42	25	4.5	4	5
K26-070	70	12	47	30	5.9	5	5
K26-075	75	12	50	30	5.9	5	5
K26-080	80	12	55	30	5.9	5	5
K26-085	85	12	60	35	7.1	6	5
K26-090	90	12	65	35	7.1	6	5
K26-100	100	12	72	35	7.1	6	7
K26-110	110	12	82	40	7	6	7
K26-120	120	20	90	40	9	8	7
K26-125	125	20	95	40	9	8	7
K26-130	130	20	100	40	9	8	7
K26-140	140	20	110	40	11	10	7
K26-145	145	20	115	45	11	10	7
K26-150	150	20	115	40	11	10	7
K26-160	160	20	125	40	11	10	7
K26-175	175	20	135	40	11	10	7
K26-180	180	20	140	40	11	10	7
K26-200	200	20	150	40	11	10	10
K26-230	230	30	175	40	13	12	10
K26-250	250	30	190	40	13	12	10
K26-300	300	60	225	40	13	12	10



K40 is a two piece single acting piston seal which consists of asymmetrical profile with pressure relieving grooves and a thermoplastic back-up ring.

PRODUCT ADVANTAGES

- Superior static and dynamic sealing effect
- Improved sealing gap thanks to the active back-up ring
- Relief grooves against dynamic pressure
- Easy assembly into the closed groove
- Simple groove design
- High wear resistant

APPLICATION

Heavy duty cylinders, scrap cutters and hydraulic jacks.

MATERIAL		CODE
PU	94 SHORE A	PU9401
POM		PM9901

OPERATING CONDITIONS			
MEDIA	Mineral oils (DIN 51524)	HFA and HFB	HFC
TEMPERATURE	-30°C 100°C	+5°C +50°C	-30°C +40°C
PRESSURE	≤400 Bar	≤400 Bar	≤400 Bar
SPEED	≤0.5 m/sec	≤0.5 m/sec	≤0.5 m/sec

Note: The above data are maximum values and cannot be used at the same time.

SURFACE ROUGHNESS		Ra	Rmax
Sliding Surface	∅D	≤0.4 μm	≤3.2 μm
Groove Base	∅d	≤1.6 μm	≤10 μm
Groove Flanks	B	≤4.0 μm	≤16 μm

Note: It is recommended to have 50% to 90% of the working surface material contact area value.

INSTALLATION

Easily assembled into one piece piston. It is very important that the assembly tools must be of soft material and have no sharp edges. Before installation all individual parts of the seal must be oiled with system oil.

NOTES

The permissible sealing gap values of K40 piston seal is given in the below table.

PERMISSIBLE SEALING GAP	
Pressure (Bar)	Smax (mm)
100	1.0
150	0.8
250	0.7
400	0.6

Note: The largest sealing gap value occurring on the non-pressurized side of the seal is vital for the function and in this respect it is quite important to use the S value lower than the above indicated numbers.



K41 is a two piece single acting piston seal which consists of one special mixture PTFE profile ring and an o-ring as energizing element.

PRODUCT ADVANTAGES

- Low friction, free of stick-slip
- Simple groove design and low axial housing heights
- Long service life
- High sliding speed
- Wide range of temperature and chemicals depending on the o-ring material
- Minimum static and dynamic friction coefficient for a minimum energy loss and operating temperature
- Wide range of dimensions

APPLICATION

Injection moulding machines, fork-lift trucks, loading platforms, cranes, agricultural machinery and valves for hydraulic and pneumatic systems.

MATERIAL		CODE
NBR	70 SHORE A	NB7001
PTFE		PT6003

OPERATING CONDITIONS

MEDIA	Mineral oils (DIN 51524)	HFA and HFB	HFC
TEMPERATURE	-30°C +105°C	+5°C +60°C	-30°C +60°C
PRESSURE	≤400 Bar	≤400 Bar	≤400 Bar
SPEED	≤5.0 m/sec	≤5.0 m/sec	≤5.0 m/sec

Note: The above data are maximum values and cannot be used at the same time.

SURFACE ROUGHNESS

		Ra	Rmax
Sliding Surface	∅D	≤0.2 μm	≤2.0 μm
Groove Base	∅d	≤1.6 μm	≤6.3 μm
Groove Flanks	B	≤3.2 μm	≤15 μm

Note: It is recommended to have 50% to 90% of the working surface material contact area value.

INSTALLATION

We recommend using special assembly tool (See section; Hydraulic Sealing Elements General Installation Information) and to have open groove design for dimensions that are smaller than ∅ 40 mm. It is very important that the assembly tools must be of soft material and have no sharp edges. Before installation the sealing element must be oiled with system oil.

NOTES

It is recommended to use with minimum two piston guide rings in long stroke cylinders, minimum one guide ring in short stroke and under low radial loads. For special applications that require high temperatures or resistance to chemicals, piston seal can be manufactured with special mixture PTFE and FKM material. The permissible sealing gap values of K41 piston seal is given in the below table.

PERMISSIBLE SEALING GAP

B (mm)	Smax(mm)		
	150 Bar	250 Bar	400 Bar
3.2	0.4	0.25	0.15
4.2	0.4	0.25	0.20
6.3	0.5	0.30	0.20
8.1	0.6	0.35	0.25
9.5	0.7	0.50	0.30

Note: The largest sealing gap value occurring on the non-pressurized side of the seal is vital for the function of the seal and in this respect it is quite important to use the S value lower than the above indicated numbers.

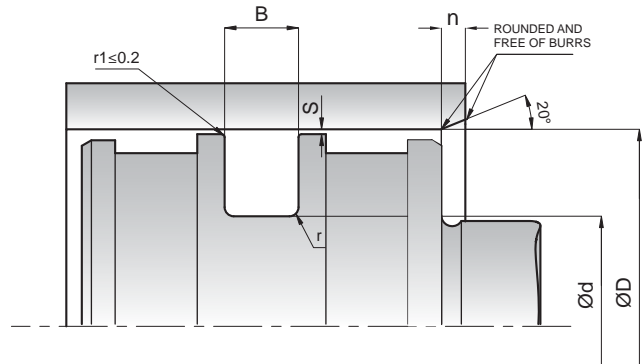
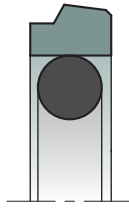

KASTAŞ NO	D (H8)	d (h9)	B (-0/+0.2)	r	n	O-Ring
K41-018	18	10.7	3.2	0.6	4.5	9.92x2.62
K41-025	25	17.7	3.2	0.6	4.5	17.13x2.62
K41-030	30	19.3	4.2	1	6	18.66x3.53
K41-030/1	30	22.7	3.2	0.6	4.5	21.89x2.62
K41-032	32	21.3	4.2	1	6	20.22x3.53
K41-040	40	29.3	4.2	1	6	28.17x3.53
K41-050	50	39.3	4.2	1	6	37.69x3.53
K41-060	60	44.9	6.3	1.3	8	43.82x5.33
K41-060/1	60	49.3	4.2	1	6	49.21x3.53
K41-063	63	47.9	6.3	1.3	8	46.99x5.33
K41-065	65	49.9	6.3	1.3	8	46.99x5.33
K41-070	70	59.3	4.2	1	6	56.74x3.53
K41-070/1	70	54.9	6.3	1.3	8	53.34x5.33
K41-075	75	59.9	6.3	1.3	8	56.52x5.33
K41-080	80	64.9	6.3	1.3	8	62.87x5.33
K41-085	85	69.9	6.3	1.3	8	69.22x5.33
K41-090	90	74.9	6.3	1.3	8	72.39x5.33
K41-095	95	79.9	6.3	1.3	8	78.74x5.33
K41-100	100	84.9	6.3	1.3	8	81.92x5.33
K41-110	110	94.9	6.3	1.3	8	91.44x5.33
K41-115	115	99.9	6.3	1.3	8	97.79x5.33
K41-120	120	104.9	6.3	1.3	8	104.14x5.33
K41-130	130	109.5	8.1	1.8	10.25	108x7
K41-130/1	130	114.9	6.3	1.3	8	113.67x5.33
K41-140	140	124.9	6.3	1.3	8	123.8x5.33
K41-150	150	134.9	6.3	1.3	8	133.35x5.33
K41-160	160	144.9	6.3	1.3	8	142.24x5.33
K41-160/1	160	139.5	8.1	1.8	10.25	135.89x6.99
K41-170	170	154.9	6.3	1.3	8	151.77x5.33
K41-180	180	164.9	6.3	1.3	8	164.47x5.33
K41-180/1	180	159.5	8.1	1.8	10.25	158.12x6.99
K41-190	190	174.9	6.3	1.3	8	170.82x5.33
K41-200	200	179.5	8.1	1.8	10.25	177.17x6.99
K41-210	210	189.5	8.1	1.8	10.25	183.52x6.99
K41-215	215	194.5	8.1	1.8	10.25	193.70x6.99
K41-220	220	199.5	8.1	1.8	10.25	196.22x6.99
K41-225	225	204.5	8.1	1.8	10.25	202.57x6.99
K41-230	230	209.5	8.1	1.8	10.25	202.57x6.99
K41-240	240	219.5	8.1	1.8	10.25	215.27x6.99
K41-250	250	229.5	8.1	1.8	10.25	227.97x6.99
K41-260	260	236	8.1	1.8	12	227.97x6.99
K41-270	270	246	8.1	1.8	12	240.67x6.99
K41-280	280	256	8.1	1.8	12	253.37x6.99
K41-290	290	266	8.1	1.8	12	259.70x6.99
K41-300	300	276	8.1	1.8	12	266.07x6.99
K41-320	320	296	8.1	1.8	12	291.47x6.99
K41-340	340	316	8.1	1.8	12	316.87x6.99
K41-460	460	436	8.1	1.8	12	430.66x6.99



K42 is a five piece double acting compact seal which consists of one multiple lip elastomeric nitrile rubber sealing element, two polyester elastomer back-up rings on both sides to prevent extrusion into the sealing gap and two special profiled thermoplastic guide rings to absorb transverse forces.

PRODUCT ADVANTAGES

- Effective sealing during vibration and shock loading
- Superior sealing effect in high pressures
- Maximum sealing efficiency with the least amount of friction
- Superior sealing performance

APPLICATION

Heavy duty cylinders, excavators, cranes, marine hydraulics and loading platforms.

MATERIAL		CODE
NBR	80 SHORE A	NB8001
TPE		TP5501
POM		PM9903

OPERATING CONDITIONS			
MEDIA	Mineral oils (DIN 51524)	HFA and HFB	HFC
TEMPERATURE	-30°C +105°C	+5°C +60°C	-30°C +60°C
PRESSURE	≤700 Bar	≤700 Bar	≤700 Bar
SPEED	≤0.5 m/sec	≤0.5 m/sec	≤0.5 m/sec

Note: The above data are maximum values and cannot be used at the same time.

SURFACE ROUGHNESS		Ra	Rmax
Sliding Surface	∅D	≤0.4 μm	≤4.0 μm
Groove Base	∅d	≤1.6 μm	≤6.3 μm
Groove Flanks	B	≤3.2 μm	≤16 μm

Note: It is recommended to have 50% to 90% of the working surface material contact area value.

INSTALLATION

K42 compact seal must be used in open housing due to the non split form of the back-up ring produced from TPE material. If it is necessary to have a closed groove, back-up rings should be cut with 45° angle in a way not to have any gap and installed afterwards. On this case after the assembly onto the piston the cut on the back-up ring should be checked carefully. It is very important that the assembly tools must be of soft material and have no sharp edges. Before installation the sealing element must be oiled with system oil.

NOTES

For special applications that require high temperatures, piston seal can be manufactured in FKM and PTFE material.

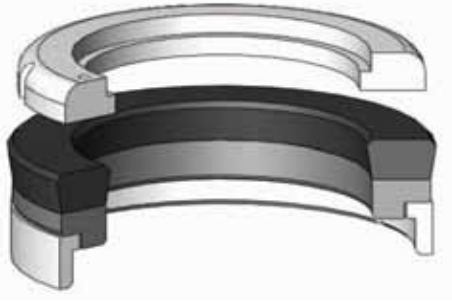

K43 is a three piece single acting sealing set which consists of one reinforced cotton fabric and nitrile rubber vulcanized together, one L shaped thermoplastic guide back-up ring and a retaining ring.

PRODUCT ADVANTAGES

- Functions even with poor surfaces
- Limited space thanks to the open housing in one-piece piston
- Reinforced cotton fabric base prevents the seal from extrusion
- Good sealing at low pressures

APPLICATION

Mining equipment, after market, mobile hydraulics, presses and standard cylinders.

MATERIAL		CODE
NBR	80 SHORE A	NB8001
COTTON FABRIC NBR		NB8008
POM		PM9901

OPERATING CONDITIONS			
MEDIA	Mineral oils (DIN 51524)	HFA and HFB	HFC
TEMPERATURE	-30°C +105°C	+5°C +60°C	-30°C +60°C
PRESSURE	≤500 Bar	≤500 Bar	≤500 Bar
SPEED	≤0.5 m/sec	≤0.5 m/sec	≤0.5 m/sec

Note: The above data are maximum values and cannot be used at the same time.

SURFACE ROUGHNESS		Ra	Rmax
Sliding Surface	ØD	≤0.4 µm	≤3.2 µm
Groove Base	Ød	≤1.8 µm	≤6.3 µm
Groove Flanks	B	≤3.2 µm	≤16 µm

Note: It is recommended to have 50% to 90% of the working surface material contact area value.

INSTALLATION

Easily assembled into one-piece piston by hand. Open groove design gives an advantage for easy machining and reducing the machining costs. It is very important that the installation tools must be of soft material and have no sharp edges. Before installation all individual parts of the seal must be oiled with system oil.

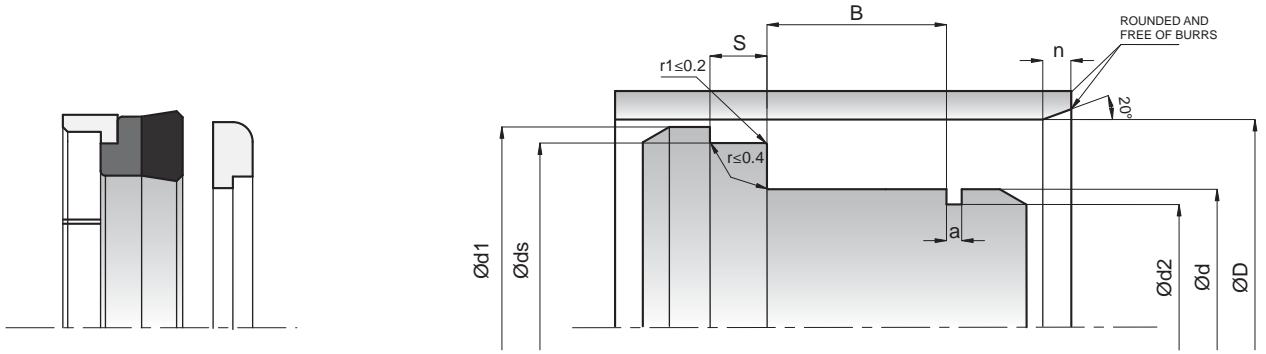

KASTAŞ NO	D (H11)	d (h9)	B (-0/+0.2)	S (-0/+0.2)	a (-0/+0.1)	ds (h8)	d2 (+0/-0.2)	d1 (± 0.1)	n
K43-032	32.00	20.00	10.00	6.35	3.10	28.50	15.80	29.80	5
K43-035	35.00	22.00	10.00	6.35	3.10	31.40	17.80	32.80	5
K43-038	38.00	25.00	10.00	6.35	3.10	34.45	20.80	35.80	5
K43-040	40.00	26.00	9.40	6.35	3.10	35.40	21.60	37.80	5
K43-045	45.00	30.00	9.50	6.35	3.10	40.40	25.80	42.80	5
K43-045/1	45.00	35.00	8.50	6.35	3.10	42.00	30.80	42.80	5
K43-050	50.00	30.00	14.50	6.35	3.35	44.30	25.80	47.50	5
K43-055	55.00	40.00	11.00	6.35	3.10	50.40	35.80	52.80	5
K43-060	60.00	40.00	14.50	6.35	3.35	54.16	36.10	57.50	5
K43-063	63.00	45.00	11.00	6.35	3.10	58.40	40.84	60.50	5
K43-063/1	63.50	47.62	9.52	6.35	3.10	58.90	41.34	61.30	5
K43-065	65.00	45.00	14.00	6.35	3.35	59.30	40.60	62.50	5
K43-065/1	65.00	50.00	10.50	6.35	3.10	60.40	45.60	62.80	5
K43-070	70.00	50.00	14.50	6.35	3.35	64.20	45.84	67.50	5
K43-075	75.00	55.00	14.50	6.35	3.35	69.20	50.60	72.50	5
K43-080	80.00	60.00	14.50	6.35	3.35	74.30	55.80	77.50	5
K43-085	85.00	70.00	12.00	6.35	3.10	80.30	65.50	82.80	5
K43-090	90.00	70.00	14.50	6.35	3.35	84.15	66.10	87.50	5
K43-095	95.00	75.00	14.50	6.35	3.20	89.15	71.00	92.50	5
K43-100	100.00	80.00	14.50	6.35	3.35	94.15	75.84	97.50	7
K43-104	104.50	85.00	13.00	6.35	3.35	98.90	81.10	102.00	7
K43-105	105.00	85.00	14.00	6.35	3.35	99.42	80.60	102.50	7
K43-110	110.00	90.00	13.00	6.35	3.10	104.15	85.90	107.50	7
K43-115	115.00	95.00	14.50	6.35	3.35	109.90	90.50	112.50	7
K43-120	120.00	100.00	12.50	6.35	3.35	114.10	95.60	117.50	7
K43-125	125.00	105.00	12.50	6.35	3.35	119.15	101.00	122.50	7
K43-130	130.00	110.00	12.00	6.35	3.35	123.24	105.60	127.50	7
K43-150	150.00	125.00	14.00	6.35	3.35	143.00	120.60	147.30	7
K43-160	160.00	140.00	14.00	6.35	3.20	154.30	136.00	157.50	7
K43-200	200.00	180.00	14.00	6.35	3.10	194.00	175.60	197.50	7

Please contact our customer service for the dimensions out of our stock list.



K751 is a two piece single acting piston seal which consists of a PTFE u-ring with metal spring as a tension component.

PRODUCT ADVANTAGES

- Superior static and dynamic sealing effect by the metal spring
- High resistance to chemicals and temperature changes
- Low friction, free of stick-slip
- High sliding speed
- Long service life
- Good dry running conditions
- Can be sterilized
- Low static and dynamic friction values

APPLICATION

Hydraulic and pneumatic cylinders, hot water valves, pumps, hot steam valves, food processing, chemical and medical technology.

MATERIAL	CODE
PTFE	PT6002
STAINLESS STEEL SPRING	CN9902

OPERATING CONDITIONS	
MEDIA	Hydraulic oils, hot air, water, steam, all media that do not react PTFE and stainless steel
TEMPERATURE	-150°C +250°C
PRESSURE	≤350 Bar
SPEED	≤15.0 m/sec

Note: The above data are maximum values and cannot be used at the same time.

SURFACE ROUGHNESS		Ra	Rmax
Sliding Surface	∅D	≤0.2 μm	≤2.0 μm
Groove Base	∅d	≤1.6 μm	≤6.3 μm
Groove Flanks	B	≤3.2 μm	≤15 μm

Note: It is recommended to have 50% to 90% of the working surface material contact area value. If the operating media is gas we recommend having Ra value not to be above 0.15 μm.

INSTALLATION

K751 is to be assembled into open and closed grooves. It is very important that the assembly tools must be of soft material and have no sharp edges. Before installation the sealing element must be oiled with system oil.

NOTES

Depending on the PTFE material application values and their resistance can change. The permissible sealing gap values of K751 spring loaded piston seal is given in the below table.

PERMISSIBLE SEALING GAP				
B (mm)	Smax (mm)			
	50 Bar	150 Bar	250 Bar	350 Bar
2.4-3.6	0.10	0.075	0.05	0.05
4.8	0.20	0.10	0.075	0.06
7.1	0.25	0.15	0.10	0.075
9.5	0.30	0.15	0.13	0.075

Note: The largest sealing gap value occurring on the non-pressurized side of the seal is vital for the function of the seal and in this respect it is quite important to use the S value lower than the above indicated numbers.

K751

SPRING LOADED PISTON SEAL

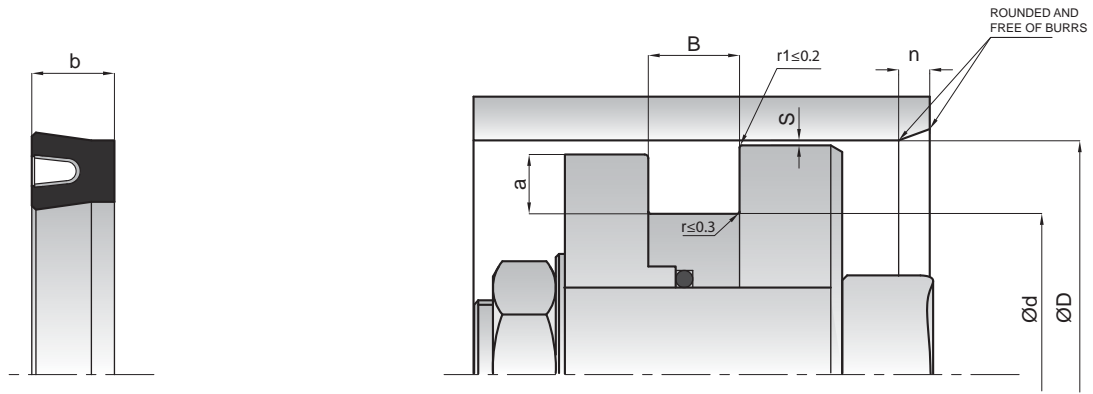

KASTAŞ NO	D (H9)	d (h9)	B (-0/+0.2)	a min.	n
K751-010	10	7.1	2.4	0.4	1.8
K751-020	20	15.5	3.6	0.6	2.8
K751-030	30	23.8	4.8	0.7	3.8
K751-040	40	33.8	4.8	0.7	3.8
K751-050	50	40.6	7.1	0.8	5.6
K751-060	60	50.6	7.1	0.8	5.6
K751-063	63	53.6	7.1	0.8	5.6
K751-070	70	60.6	7.1	0.8	5.6
K751-080	80	70.6	7.1	0.8	5.6
K751-085	85	75.6	7.1	0.8	5.6
K751-090	90	80.6	7.1	0.8	5.6
K751-100	100	90.6	7.1	0.8	5.6
K751-110	110	100.6	7.1	0.8	5.6
K751-120	120	110.6	7.1	0.8	5.6
K751-130	130	117.8	9.5	0.8	7.6
K751-140	140	127.8	9.5	0.8	7.6
K751-150	150	137.8	9.5	0.8	7.6
K751-160	160	147.8	9.5	0.8	7.6
K751-170	170	157.8	9.5	0.8	7.6



K753 is a three piece double acting sealing set which consists of one special mixture PTFE profile ring, one X-ring as for main sealing element and an O-ring as energizing element.

PRODUCT ADVANTAGES

- Wide range of temperature and chemicals depending on the o-ring and x-ring material
- Low friction, free of stick-slip
- High sealing effect in applications requiring media separation
- Low gas permeability rate
- Minimum static and dynamic friction coefficient for a minimum energy loss and operating temperature
- Simple groove design and low axial housing heights

APPLICATION

Accumulators, heavy duty cylinders, presses and machine tools.

MATERIAL		CODE
NBR	70 SHORE A	NB7001
PTFE		PT6003

OPERATING CONDITIONS			
MEDIA	Mineral oils (DIN 51524)	HFA and HFB	HFC
TEMPERATURE	-30°C +105°C	+5°C +60°C	-30°C +60°C
PRESSURE	≤400 Bar	≤400 Bar	≤400 Bar
SPEED	≤2.0 m/sec	≤2.0 m/sec	≤2.0 m/sec

Note: The above data are maximum values and cannot be used at the same time.

SURFACE ROUGHNESS		Ra	Rmax
Sliding Surface	ØD	≤0.2 µm	≤2.0 µm
Groove Base	Ød	≤1.6 µm	≤6.3 µm
Groove Flanks	B	≤3.2 µm	≤15 µm

Note: It is recommended to have 50% to 90% of the working surface material contact area value.

INSTALLATION

It is recommended to assembled into one piece piston with special assembly tool (See section; Hydraulic Sealing Elements General Installation Information). It is very important that the assembly tools must be of soft material and have no sharp edges. Before installation the sealing element must be oiled with system oil.

NOTES

It is recommended to use with minimum two piston guide rings in long stroke cylinders, minimum one guide ring in short stroke and low radial loaded cylinders. For special applications that require high temperatures or resistance to chemicals, piston seal is being manufactured with special mixture PTFE and FKM material. The permissible sealing gap values of K753 piston seal is given in the below table.

PERMISSIBLE SEALING GAP			
B (mm)	Smax (mm)		
	150 Bar	250 Bar	400 Bar
4.2	0.25	0.15	0.10
6.3	0.30	0.20	0.15
8.1	0.30	0.20	0.15
9.5	0.50	0.25	0.20

Note: The largest sealing gap value occurring on the non-pressurized side of the seal is vital for the function of the seal and in this respect it is quite important to use the S value lower than the above indicated numbers.

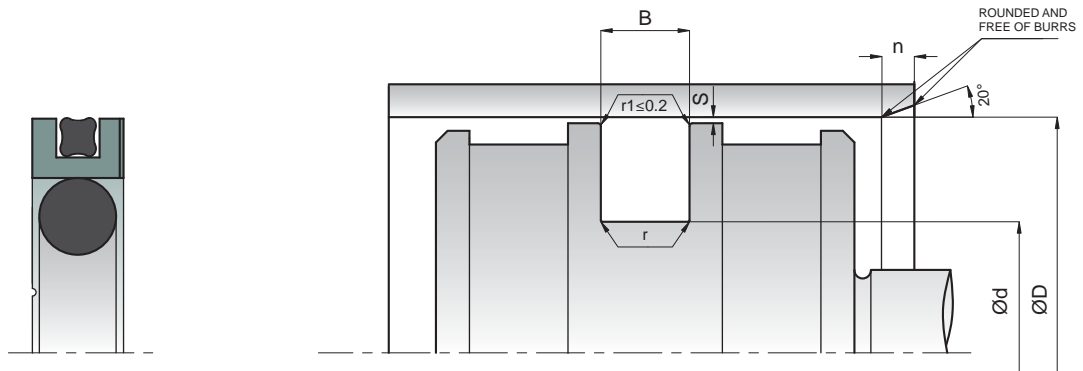

KASTAŞ NO	D (H9)	Ød (h9)	B (-0/+0.2)	r	n	O-Ring	X-Ring
K753-016	16	5	4.2	1	1	4.34x3.53	12.42x1.78
K753-022	22	11	4.2	1	1	10.69x3.53	17.17x1.78
K753-025	25	14	4.2	1	1	13.87x3.53	20.35x1.78
K753-028	28	17	4.2	1	1	15.47x3.53	23.52x1.78
K753-030	30	19	4.2	1	1	18.66x3.53	25.12x1.78
K753-032	32	21	4.2	1	1	20.22x3.53	26.70x1.78
K753-035	35	24	4.2	1	1	23.40x3.53	29.87x1.78
K753-040	40	29	4.2	1.3	1	28.17x3.53	34.65x1.78
K753-042	42	31	4.2	1.3	1	29.75x3.53	37.82x1.78
K753-045	45	34	4.2	1.3	1	32.92x3.53	37.82x1.78
K753-050	50	39	4.2	1.3	1	37.69x3.53	44.17x1.78
K753-050/1	50	34.5	6.3	1.3	1.3	32.69x5.33	44.17x1.78
K753-052	52	41	4.2	1.3	1	40.87x3.53	47.35x1.78
K753-055	55	44	4.2	1.3	1	44.04x3.53	50.52x1.78
K753-060	60	49	4.2	1.3	1	47.22x3.53	53.70x1.78
K753-063	63	52	4.2	1.3	1	50.39x3.53	56.87x1.78
K753-063/1	63	47.5	6.3	1.3	1.3	46.99x5.33	56.87x1.78
K753-065	65	54	4.2	1.3	1	53.57x3.53	60.05x1.78
K753-070	70	59	4.2	1.3	1	56.74x3.53	63.22x1.78
K753-070/1	70	54.5	6.3	1.3	1.3	53.34x5.33	63.22x1.78
K753-075	75	64	4.2	1.3	1	63.09x3.53	69.57x1.78
K753-080	80	64.5	6.3	1.8	1.3	62.87x5.33	72.75x1.78
K753-080/1	80	59	8.1	1.8	1.8	58.00x6.99	71.12x2.62
K753-085	85	69.5	6.3	1.8	1.3	69.22x5.33	75.92x1.78
K753-090	90	74.5	6.3	1.8	1.3	72.39x5.33	82.27x1.78
K753-095	95	79.5	6.3	1.8	1.3	78.74x5.33	88.62x1.78
K753-100	100	84.5	6.3	1.8	1.3	81.92x5.33	88.62x1.78
K753-105	105	89.5	6.3	1.8	1.3	88.27x5.33	94.97x1.78
K753-110	110	94.5	6.3	1.8	1.3	91.44x5.33	101.32x1.78
K753-115	115	99.5	6.3	1.8	1.3	97.79x5.33	107.67x1.78
K753-120	120	104.5	6.3	1.8	1.3	100.97x5.33	114.02x1.78
K753-125	125	109.5	6.3	1.8	1.3	107.32x5.33	114.02x1.78
K753-130	130	114.5	6.3	1.8	1.3	113.67x5.33	120.37x1.78
K753-135	135	114	8.1	1.8	1.8	113.67x6.99	126.67x2.62
K753-140	140	119	8.1	1.8	1.8	116.84x6.99	126.67x2.62
K753-150	150	129	8.1	1.8	1.8	126.37x6.99	139.37x2.62
K753-160	160	139	8.1	1.8	1.8	135.89x6.99	145.72x2.62
K753-170	170	149	8.1	1.8	1.8	145.42x6.99	158.42x2.62
K753-180	180	159	8.1	1.8	1.8	158.12x6.99	171.11x2.62
K753-190	190	169	8.1	1.8	1.8	164.47x6.99	177.47x2.62
K753-200	200	179	8.1	1.8	1.8	177.17x6.99	190.17x2.62
K753-210	210	189	8.1	1.8	1.8	183.52x6.99	196.52x2.62
K753-220	220	199	8.1	1.8	1.8	196.22x6.99	202.87x2.62
K753-240	240	219	8.1	1.8	1.8	215.27x6.99	221.92x2.62
K753-250	250	229	8.1	1.8	1.8	227.97x6.99	234.62x2.62
K753-250/1	250	225.5	8.1	1.8	1.8	227.97x6.99	234.62x2.62



Blank lined writing area consisting of 25 horizontal light gray lines.

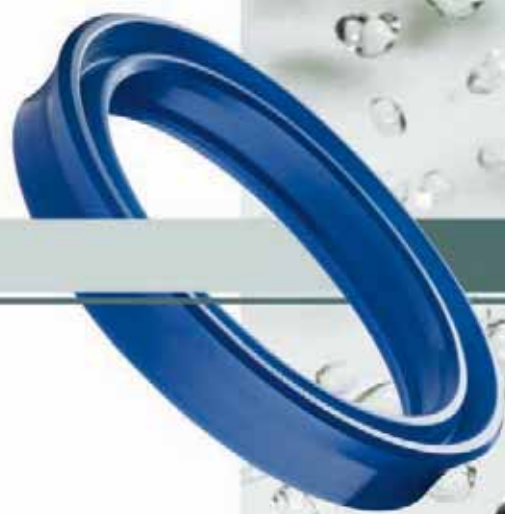

WIPERS



20 horizontal light gray lines for writing.

KASTAŞ CODE	PRODUCT NAME	DRAWING	APPLICATION	MATERIAL	CODE	PRESSURE (max) bar	TEMPERATURE (max) °C	SLIDING SPEED (max) - m/sn	PAGE NO
K05	Wiper		Rod	PU	PU9501		-30/+100	1.0	158
K06	Wiper		Rod	NBR PU	NB9001 PU9201		-30/+105 -30/+100	1.0 1.0	160
K07 NBR	Metal Case Wiper		Rod	NBR STEEL	NB9001 FE9901		-30/+105	1.0	166
K07 PU	Metal Case Wiper		Rod	PU STEEL	PU9201 FE9901		-30/+100	1.0	168
K09	Wiper		Rod	NBR PU	NB9001 PU9201		-30/+105 -30/+100	1.0 1.0	170
K10	Double Wiper		Rod	NBR	NB9001		-30/+105	1.0	174
K11	Wiper		Rod	TPE	TP5501		-40/+120	2.0	178
K12	Metal Case Double Wiper		Rod	PU STEEL	PU9501 FE9901		-30/+100	1.0	182
K27	Double Wiper		Rod	NBR PU	NB9001 PU9201		-30/+105 -30/+100	1.0 1.0	184
K703	Wiper		Rod	NBR PTFE	NB7001 PT6003		-30/+105	5.0	186



K05 is a single acting wiper ensuring that foreign particles do not penetrate into the hydraulic systems, avoiding wear and damage to all the internal components including seals.

PRODUCT ADVANTAGES

- Superior wiping performance
- Improved wiping effect of dirt, water spray, etc with the help of the secondary sealing lip on the outer diameter
- Simple, easy-construction groove
- Wide range of dimensions
- No twisting in the housing
- Used in heavy conditions by the good tear and rupture properties of PU material.
- Easy installation
- Specially design to prevent big particles to go into the system

APPLICATION

Used especially in earth moving equipment, agricultural machinery, telescopic cylinders, cranes, mining equipment and loading platforms.

MATERIAL		CODE
PU	95 SHORE A	PU9501

OPERATING CONDITIONS			
MEDIA	Mineral oils (DIN 51524)	HFA and HFB	HFC
TEMPERATURE	-30°C +100°C	+5°C +50°C	-30°C +40°C
SPEED	≤1.0 m/sec	≤1.0 m/sec	≤1.0 m/sec

Note: The above data are maximum values and cannot be used at the same time.

SURFACE ROUGHNESS		Ra	Rmax
Sliding Surface	Ød	≤0.4 µm	≤3.2 µm
Groove Base	ØD	≤1.6 µm	≤10 µm
Groove Flanks	S1	≤3.2 µm	≤16 µm

INSTALLATION

Generally, wiper can be easily fitted into the closed housing by deforming into a kidney shape. It is very important that the assembly tools must be of soft material and have no sharp edges. Before installation the wiper must be oiled with system oil.

NOTES

K05 wipers are single acting and can be used with combination of all rod sealing elements.

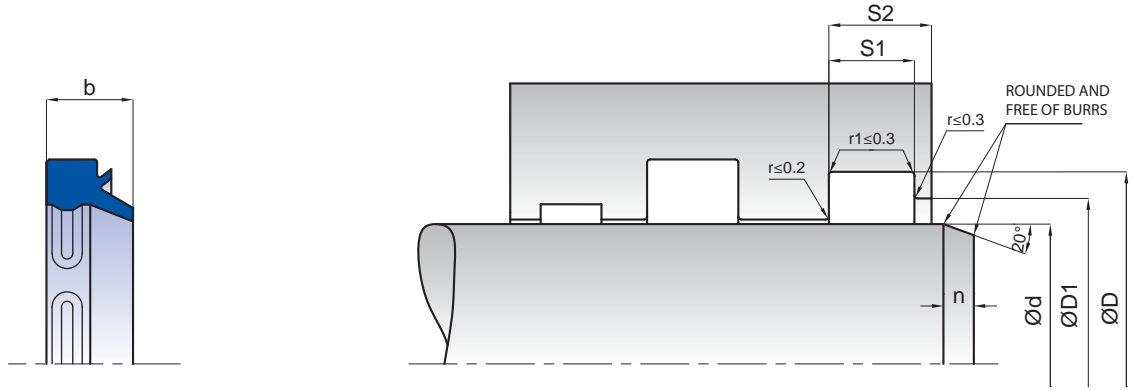

KASTAŞ NO	d (f8)	D (H10)	D1 (H11)	S1 (-0/+0.2)	S2	b
K05-016 PU	16	24	22	4	5	7
K05-018 PU	18	26	24	4	5	7
K05-020 PU	20	28	26	4	5	7
K05-022 PU	22	30	28	4	5	7
K05-025 PU	25	33	31	4	5	7
K05-028 PU	28	36	34	4	5	7
K05-030 PU	30	38	36	4	5	7
K05-032 PU	32	40	38	4	5	7
K05-035 PU	35	43	41	4	5	7
K05-036 PU	36	44	42	4	5	7
K05-040 PU	40	48	46	4	5	7
K05-045 PU	45	53	51	4	5	7
K05-050 PU	50	58	56	4	5	7
K05-055 PU	55	63	61	4	5	7
K05-060 PU	60	68	66	4	5	7
K05-063 PU	63	71	69	4	5	7
K05-065 PU	65	73	71	4	5	7
K05-065/1 PU	65	75	72	7	8	9.5
K05-070 PU	70	78	76	4	5	7
K05-075 PU	75	83	81	4	5	7
K05-080 PU	80	88	86	4	5	7
K05-085 PU	85	93	91	4	5	7
K05-090 PU	90	98	96	4	5	7
K05-100 PU	100	108	106	4	5	7
K05-110 PU	110	122	119	5.5	7	10
K05-115 PU	115	127	124	5.5	7	10
K05-120 PU	120	132	129	5.5	7	10
K05-125/1 PU	125	137	134	5.5	7	10
K05-125 PU	125	140	135	9.5	12	13
K05-130 PU	130	142	139	5.5	7	10
K05-140 PU	140	152	149	5.5	7	10
K05-150 PU	150	162	159	5.5	7	10
K05-160 PU	160	172	169	5.5	7	10
K05-170 PU	170	182	179	5.5	7	10
K05-180 PU	180	192	189	5.5	7	10
K05-200 PU	200	212	209	5.5	7	10



K06 is a single acting wiper ensuring that foreign particles do not penetrate into the hydraulic systems, avoiding wear and damage to all the internal components including seals.

PRODUCT ADVANTAGES

- Very good wiping performance
- Simple, easy-construction groove
- Wide range of dimensions
- No twisting in the housing
- Easy installation
- Specially designed to prevent big particles to go into the system
- Used in heavy conditions by the good mechanical properties of Polyurethane material.

APPLICATION

Construction machinery, forklift-trucks, injection moulding machines, agricultural machinery and standard cylinders.

MATERIAL		CODE
NBR	90 SHORE A	NB9001
PU	92 SHORE A	PU9201

OPERATING CONDITIONS			
NBR			
MEDIA	Mineral oils (DIN 51524)	HFA and HFB	HFC
TEMPERATURE	-30°C +105°C	+5°C +60°C	-30°C +60°C
SPEED	≤1.0 m/sec	≤1.0 m/sec	≤1.0 m/sec

POLYURETHANE			
MEDIA	Mineral oils (DIN 51524)	HFA and HFB	HFC
TEMPERATURE	-30°C +100°C	+5°C +50°C	-30°C +40°C
SPEED	≤1.0 m/sec	≤1.0 m/sec	≤1.0 m/sec

Note: The above data are maximum values and cannot be used at the same time.

SURFACE ROUGHNESS	Ra	Rmax
Sliding Surface	≤0.4 μm	≤3.2 μm
Groove Base	≤1.6 μm	≤10 μm
Groove Flanks	≤3.2 μm	≤16 μm

INSTALLATION

Generally, wiper can be easily fitted into the closed housing by deforming into a kidney shape. It is very important that the assembly tools must be of soft material and have no sharp edges. Before installation the wiper must be oiled with system oil.

NOTES

K06 wipers are single acting and can be used with combination of all rod sealing elements. K06 wipers can be produced on request in FKM material for special applications that require high temperatures.

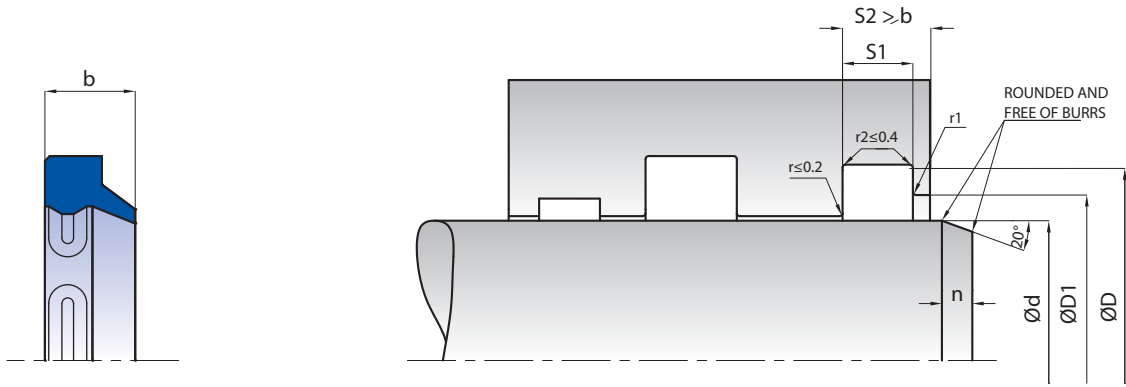

KASTAŞ NO	NBR	PU	d (f8)	D (H10)	D1 (H11)	S1 (-0/+0.2)	b	r1
K06-005	NBR	PU	5	12	9	2.8	4	1
K06-008/2	NBR	PU	8	14.6	11	3.8	4.5	1
K06-010	NBR		10	14.2	12.2	2.3	3	1
K06-010/2		PU	10	16	12.8	3.8	5	1
K06-010/1		PU	10	18	12.4	5.3	8	1
K06-012/1	NBR	PU	12	18.6	14	3.7	5.5	1
K06-012/4	NBR	PU	12	18.6	15	3.8	5	1
K06-12/2	NBR		12	20.7	18.3	5	7	1
K06-014	NBR	PU	14	18.6	17	2.3	3.3	1
K06-014/1	NBR	PU	14	20.6	17	3.8	5	1
K06-015/1	NBR	PU	15	21.8	18	3.8	5	1
K06-015/2	NBR	PU	15	27.3	18.5	5.3	7	1
K06-016/1	NBR	PU	16	22.6	19	3.7	5.5	1
K06-016/2	NBR	PU	16	22.6	19	3.9	5	1
K06-016/3	NBR	PU	16	22.8	19	3.1	4	1
K06-016	NBR	PU	16	24.6	19	5.3	7	1
K06-018/3	NBR	PU	18	24	20.4	3.8	5	1
K06-018	NBR	PU	18	26.6	21	5.3	7	1
K06-018/1	NBR		18	30.3	21.1	5.4	7	1
K06-019/1	NBR		19	28.4	23	5.3	7	1
K06-019	NBR	PU	19.05	28.49	23.4	4.76	7.15	1
K06-020/1	NBR		20	25	23	4.3	6	1
K06-020	NBR	PU	20	28.6	23	5.3	7	1
K06-020/2		PU	20	30	22.4	5.3	7	1
K06-022/2	NBR	PU	22	30.2	25	2.3	3.5	1
K06-022	NBR	PU	22	30.6	25	5.3	7	1
K06-022/1		PU	22.22	31.75	28.15	4.74	7.1	1
K06-024/1	NBR	PU	24	32	26.8	2.3	3.5	1
K06-024	NBR	PU	24	32.6	27	5.3	7	1
K06-025/2	NBR	PU	25	30	27.2	4.8	6.50	1
K06-025/4	NBR		25	30	27.8	4.3	6	1
K06-025	NBR	PU	25	33.6	28	5.3	7	1
K06-025/1	NBR	PU	25.4	34.93	28.4	4.76	7.15	1
K06-027	NBR	PU	27	35	29.4	5.3	7	1
K06-028	NBR	PU	28	36.6	31	5.3	7	1
K06-028/1	NBR		28	38.2	31	5.3	7	1
K06-030	NBR	PU	30	38.6	33	5.3	7	1
K06-030/3	NBR	PU	30	40.2	34.2	3.1	4	1
K06-030/1	NBR	PU	30	45	35.4	5.3	8	1
K06-031/1	NBR	PU	31.75	41.27	37.97	4.76	7.15	1
K06-032/2	NBR	PU	32	40.2	35	3.8	5	1
K06-032	NBR	PU	32	40.6	35	5.3	7	1
K06-033	NBR	PU	33	42	35.4	5.3	7	1
K06-034	NBR	PU	34.92	44.45	41.15	4.76	7.15	1
K06-035/3	NBR	PU	35	40.2	38	3.8	5	1
K06-035	NBR	PU	35	43.6	38	5.3	7	1
K06-035/1	NBR		35	47.50	38.3	5.3	7	1
K06-036	NBR	PU	36	44.6	39	5.3	7	1
K06-036/1	NBR		36	48.2	39.4	5.3	7	1

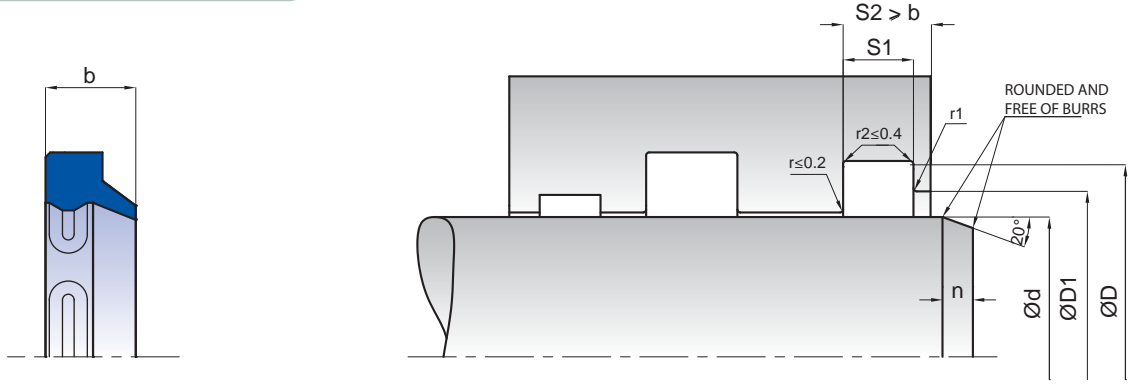

KASTAŞ NO	NBR	PU	d (f8)	D (H10)	D1 (H11)	S1 (-0/+0.2)	b	r1
K06-038/1	NBR	PU	38	46.6	41	5.3	7	1
K06-038	NBR	PU	38.1	47.62	44.45	4.76	7.15	1
K06-040	NBR	PU	40	48.6	43	5.3	7	1
K06-040/1	NBR	PU	40	48.6	43	4.3	7	1
K06-040/3	NBR	PU	40	50.6	43	5.3	7	1
K06-040/2	NBR	PU	40	52.2	46	5.3	8	1
K06-040/4	NBR		40	52.2	46	6.3	8	1
K06-042	NBR	PU	42	50.6	45	5.3	7	1
K06-043	NBR		43	55	48.4	5.3	7	1
K06-044	NBR	PU	44.45	53.97	50.67	4.76	7.15	1
K06-045/1	NBR	PU	45	53.6	48	5.3	7	1
K06-045	NBR	PU	45	55.6	48	5.3	7	1
K06-045/2	NBR	PU	45	60	52.4	4.3	6	1
K06-046	NBR	PU	46	54	48.4	5.3	7	1
K06-048	NBR	PU	48	56.6	51	5.3	7	1
K06-050/1	NBR	PU	50	58.6	53	5.3	7	1
K06-050/4	NBR	PU	50	58.6	53	4.3	6	1
K06-050	NBR	PU	50	60.6	53	5.3	7	1
K06-050/6	NBR		50	62	55	5.3	7	1
K06-050/8	NBR	PU	50	65.6	53.2	4.3	6	1
K06-050/2	NBR		50	65.6	58	7.8	12	1.5
K06-050/5	NBR		50.8	63	57.4	6.7	9.52	1
K06-050/3	NBR	PU	50.8	63.5	57	6.35	9.52	1
K06-053	NBR	PU	53	61.6	56.2	5.3	7	1
K06-055/2	NBR	PU	55	63.6	58	5.3	7	1
K06-055	NBR	PU	55	65.6	58	5.3	7	1
K06-055/1	NBR	PU	55	67.2	61	7.2	12	1
K06-056/1	NBR	PU	56	64.6	59	5.3	7	1
K06-056	NBR	PU	56	66.6	59	5.3	7	1
K06-057	NBR	PU	57	69.85	63.85	6.35	9.52	1
K06-058	NBR	PU	58	68.6	61	5.3	7	1
K06-060/1	NBR	PU	60	68.6	63	5.3	7	1
K06-060/2	NBR	PU	60	70.3	63	7.2	10	1
K06-060	NBR	PU	60	70.6	63	5.3	7	1
K06-060/3	NBR	PU	60	70.60	63	6.3	10	1
K06-060/4	NBR	PU	60.32	73.02	67.42	6.42	9.52	1
K06-061		PU	61	69.6	64	5.3	7	1
K06-063/1	NBR	PU	63	71.6	66	5.3	7	1
K06-063	NBR	PU	63	73.6	66	5.3	7	1
K06-063/4	NBR		63	75.2	69	6.3	9	1
K06-063/2	NBR	PU	63.5	76.12	70.2	6.35	9.52	1
K06-065/1	NBR	PU	65	73.6	68	5.3	7	1
K06-065	NBR	PU	65	75.6	68	5.3	7	1
K06-065/2	NBR	PU	65	77.2	71	7.2	12	1
K06-069		PU	69.72	79.62	73.22	4.76	6.35	1
K06-070/1	NBR	PU	70	78.6	73	5.3	7	1
K06-070/5		PU	70	80	74.8	6.8	8	1
K06-070	NBR	PU	70	80.6	73	5.3	7	1
K06-070/2		PU	70	80.6	73	7.2	10	1

KASTAŞ NO	NBR	PU	d (f8)	D (H10)	D1 (H11)	S1 (-0/+0.2)	b	r1
K06-070/3	NBR	PU	70	82.6	76	7.2	12	1
K06-073		PU	73	81.6	76	5.3	7	1
K06-073/1		PU	73	83.6	76.2	7.3	12	1
K06-075/1	NBR	PU	75	83.2	78	5.3	7	1
K06-075/3		PU	75	85	79.8	6.8	8	1
K06-075/2	NBR		75	85.6	78	5.3	7	1
K06-075	NBR	PU	75	87.2	81	7.2	12	1
K06-076/1		PU	76	84.6	79	5.3	7	1
K06-076		PU	76.2	88.8	84.5	6.35	9.52	1
K06-078		PU	78	92.2	85	7.3	12	1
K06-080/1	NBR	PU	80	88.6	83	5.3	7	1
K06-080/3		PU	80	90	84.8	6.8	8	1
K06-080/2		PU	80	90.2	83	6.3	9	1
K06-080	NBR	PU	80	92.2	86	7.2	12	1
K06-082	NBR		82	95	87.8	5.3	7	1
K06-085/1	NBR	PU	85	93.6	88	5.3	7	1
K06-085/2		PU	85	95	87.4	5.3	7	1
K06-085/3		PU	85	95	89.8	6.8	8	1
K06-085	NBR	PU	85	97.2	91	7.2	12	1
K06-088/1	NBR		88	100.2	94	7.3	12	1
K06-088		PU	88.9	101.5	97.21	6.35	9.52	1
K06-090/3	NBR		90	98	92.4	5.3	7	1
K06-090/6		PU	90	100	94.8	6.8	8	1
K06-090/4		PU	90	100	96.8	6.3	9	1
K06-090/1	NBR		90	100.6	93	7.2	12	1
K06-090	NBR	PU	90	102.2	96	7.2	12	1
K06-091		PU	91	99.6	94	5.3	7	1
K06-095/1	NBR	PU	95	103.6	98	5.3	7	1
K06-095/2		PU	95	105.2	97.6	6.35	8	1
K06-095	NBR	PU	95	107.2	101	7.2	12	1
K06-095/3		PU	95.12	105.62	99.22	4.76	6.35	1
K06-100/1	NBR		100	108.6	103	5.3	7	1
K06-100/3	NBR		100	108.6	103	6	8	1
K06-100/4		PU	100	110	104.8	6.8	8	1
K06-100/5	NBR		100	110.6	102.8	5.3	7	1
K06-100	NBR	PU	100	112.2	106	7.2	12	1
K06-100/2		PU	100	115.2	108	9.5	13	1.5
K06-101		PU	101.6	114.3	109.91	6.35	9.52	1
K06-103	NBR		103	115.2	109	7.3	12	1
K06-105/1	NBR	PU	105	113.6	108	5.3	7	1
K06-105	NBR	PU	105	117.2	111	7.2	12	1
K06-105/2		PU	105	120.4	112.4	7.5	9.5	1.5
K06-106		PU	106	118	113.4	6	9	1
K06-110/1	NBR		110	118.6	113	5.3	7	1
K06-110	NBR	PU	110	122.2	116	7.2	12	1
K06-110/3		PU	110	125.2	118	9.5	13	1.5
K06-113		PU	113	125	118.4	7.3	12	1
K06-115/1	NBR	PU	115	123.2	118	5.3	7	1
K06-115/2	NBR		115	125.6	118	5.3	7	1
K06-115	NBR	PU	115	127.2	121	7.2	12	1
K06-118		PU	118	126	121	5	7	1
K06-120/3	NBR		120	128.6	123	5.3	7	1
K06-120/2	NBR	PU	120	130	122.4	5.3	7	1
K06-120	NBR	PU	120	132.2	126	7.2	12	1
K06-120/1		PU	120.52	130.42	124.02	4.77	6.35	1
K06-123		PU	123	131	125.4	5.3	7	1
K06-125/1	NBR	PU	125	133.6	128	5.3	7	1
K06-125/2	NBR	PU	125	137.6	131	7.2	12	1
K06-125/5		PU	125	138	131.8	7.8	10	1
K06-125/4		PU	125	140	132.4	9.3	15	1.5
K06-125	NBR	PU	125	140	132.5	10.2	16	1.5
K06-127		PU	127	146.05	139.52	9.52	12.7	1.5
K06-128		PU	128	140.2	134	7.3	12	1
K06-130/1	NBR	PU	130	142.6	136	7.2	12	1
K06-130	NBR		130	145	137.5	10.2	16	1.5

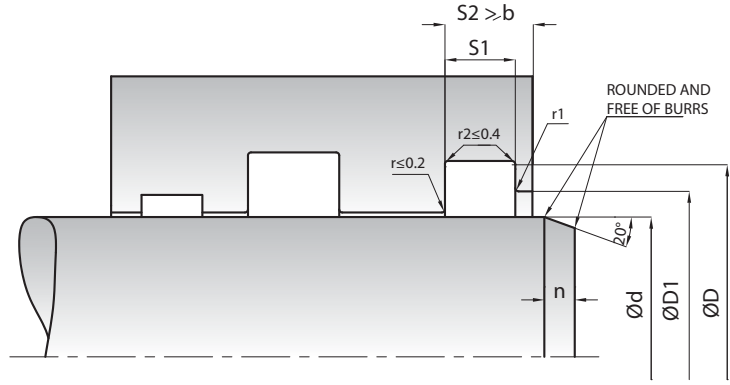
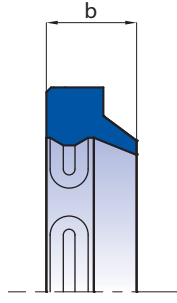

KASTAŞ NO	NBR	PU	d (f8)	D (H10)	D1 (H11)	S1 (-0/+0.2)	b	r1
K06-135	NBR	PU	135	147	141	7.2	12	1
K06-135/2	NBR		135	149.2	141	7.3	12	1.5
K06-140/8		PU	140	148.6	142.8	5.3	7	1
K06-140/5		PU	140	148.6	143	6	8	1
K06-140/4	NBR		140	150	142.4	5.3	7	1
K06-140/2	NBR		140	152.2	145.6	7.3	12	1
K06-140/6		PU	140	152.2	146	7.3	12	1
K06-140/7		PU	140	153	146.8	7.8	10	1
K06-140/3		PU	140	155	147.4	9	12	1.5
K06-140	NBR	PU	140	155	147.5	10.2	16	1.5
K06-142/1		PU	142	150.7	146.1	5.3	7	1
K06-142/2		PU	142	154	147.4	7.3	12	1
K06-143		PU	143	151	146	5.5	7	1
K06-145		PU	145	153.6	148	5.3	7	1
K06-145/3		PU	145	157.2	151	7.3	12	1
K06-145/1		PU	145	160.2	152.6	9.3	16	1.5
K06-145/2		PU	145.92	156.42	150	4.76	6.35	1
K06-150/2		PU	150	162	156	7.2	12	1
K06-150	NBR	PU	150	165	157.5	10.2	16	1.5
K06-155	NBR		155	167	161	10.2	12	1
K06-155/2		PU	155	170	170	6.5	10	1
K06-155/1		PU	155	170	162.5	10.2	16	1.5
K06-160/5		PU	160	168	162.4	5.3	7	1
K06-160/1	NBR	PU	160	172	166	7.2	12	1
K06-160/7		PU	160	173	166.8	7.8	10	1
K06-160/6		PU	160	175	167.4	9.5	13	1.5
K06-160	NBR	PU	160	175	167.5	10.2	16	1.5
K06-163	NBR	PU	163	175.80	169	7.3	12	1
K06-170/1		PU	170	182	176	10.3	16	1
K06-170/2	NBR	PU	170	182.2	176	7.2	12	1
K06-170	NBR	PU	170	185	177.5	10.2	16	1.5
K06-171		PU	171	186.2	178.6	10.3	16	1.5
K06-171/1		PU	171.32	181.82	175.6	4.76	6.35	1
K06-172		PU	172	184	177.4	7.3	12	1
K06-180/1		PU	180	188	182.4	5.3	7	1
K06-180/2		PU	180	193	186.8	7.8	10	1
K06-180/3		PU	180	195	189.8	9.5	14	1.5
K06-180	NBR	PU	180	200	190	10.2	18	3
K06-185	NBR	PU	185	197	191	7.2	12	1
K06-190	NBR	PU	190	210	199	10.2	18	3
K06-195		PU	195	210	202.5	9.3	16	1.5
K06-200/4		PU	200	213	206.8	7.8	10	1
K06-200/1		PU	200	215	207.4	9.6	12.3	1.5
K06-200/2		PU	200	215	207.4	10.2	16	1.5
K06-200	NBR	PU	200	220	210	10.2	18	3
K06-200/3		PU	200.78	211.19	205	4.76	6.35	1
K06-210/1	NBR	PU	210	225	217.6	10.2	16	1.5
K06-210	NBR		210	230	220	10.2	18	3
K06-212	NBR	PU	212	224	219	7.2	12	1

KASTAŞ NO	NBR	PU	d (f8)	D (H10)	D1 (H11)	S1 (-0/+0.2)	b	r1
K06-215		PU	215	237	225.4	10.3	18	3
K06-220/3	NBR		220	235	227.4	10.3	12	1.5
K06-220	NBR	PU	220	235	227.6	10.2	18	1.5
K06-220/1		PU	220	240	227.6	10.2	16	3
K06-220/2	NBR		220	240	230	10.2	18	3
K06-225	NBR		225	245	234.8	10.2	18	3
K06-230/1		PU	230	244	236.8	7.8	10	1
K06-230	NBR	PU	230	250	240	10.2	18	3
K06-240/1	NBR		240	248	243.4	5.3	7	1
K06-240/2		PU	240	255.2	248	10.3	16	1.5
K06-240	NBR		240	260	250	10.2	18	3
K06-250	NBR		250	270	260	10.2	18	3
K06-260	NBR		260	280	270	10.2	18	3
K06-270/1	NBR		270	285	277.4	8.3	12	1.5
K06-270	NBR		270	290	280	10.2	18	3
K06-280	NBR	PU	280	300	290	10.3	18	3
K06-300	NBR		300	320	310	10.2	18	3
K06-320	NBR		320	335	327.4	8.3	12	1.5
K06-330/1	NBR		330	346.2	337.6	10.3	16	1.5
K06-330	NBR		330	354	339.4	8.2	15	3
K06-380		PU	380	400	390	10.2	18	3



K07 is a single acting wiper ensuring that foreign particles do not penetrate into the hydraulic systems, avoiding wear and damage to all the internal components including seals.

PRODUCT ADVANTAGES

- Superior wiping performance
- Axially open, easy-construction groove
- Secure seating, press fitting into the housing
- Space-saving construction

APPLICATION

Light and medium duty construction machinery, fork-lift trucks, agricultural machinery, support cylinders and standard cylinders.

MATERIAL		CODE
NBR	90 SHORE A	NB9001
STEEL	ST37	FE9901

OPERATING CONDITIONS			
MEDIA	Mineral oils (DIN 51524)	HFA and HFB	HFC
TEMPERATURE	-30°C +105°C	+5°C +60°C	-30°C +60°C
SPEED	≤1.0 m/sec	≤1.0 m/sec	≤1.0 m/sec

Note: The above data are maximum values and cannot be used at the same time.

SURFACE ROUGHNESS		Ra	Rmax
Sliding Surface	Ød	≤0.4 µm	≤3.2 µm
Groove Base	ØD	≤1.6 µm	≤10 µm
Groove Flanks	S1	≤3.2 µm	≤16 µm

INSTALLATION

Wiper is pressed into axially open housings. Special equipment should be used during this process. It is very important that the assembly tools must be of soft material and have no sharp edges. Before installation the wiper must be oiled with system oil.

NOTES

K07 wipers are single acting and can be used with combination of all rod sealing elements. K07 wipers can be produced on requests in FKM for special applications that require high temperatures.

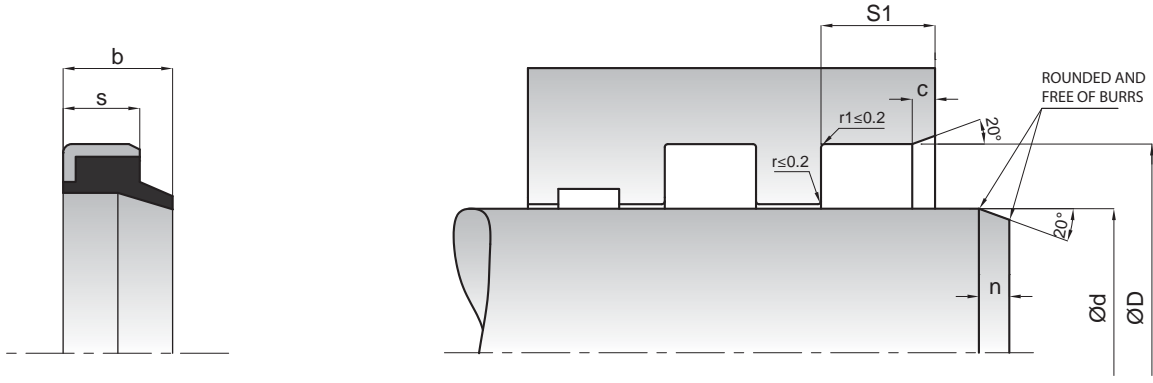

KASTAŞ NO.	d (f8)	D (H8)	s/s1	b	c
K07-020	20	30	7	10	1.4
K07-022/1	22	30	5	8	1
K07-022/2	22	32	7	10	1.4
K07-025	25	35	7	10	1.4
K07-030	30	40	5	7	0.8
K07-030/1	30	40	7	10	1.4
K07-032	32	40	7	10	1.4
K07-032/1	32	45	7	10	1.4
K07-035	35	45	7	10	1.4
K07-036	36	46	7	10	1.4
K07-040	40	50	7	10	1.4
K07-040/1	40	50	5	8	1
K07-045	45	55	7	10	1.4
K07-050	50	60	7	10	1.4
K07-050/1	50	56	5	7	0.8
K07-055	55	65	7	10	1.4
K07-060	60	70	7	10	1.4
K07-063	63	75	7	10	1.4
K07-065	65	75	7	10	1.4
K07-070	70	80	7	10	1.4
K07-070/1	70	80	5	7	0.8
K07-075	75	85	7	10	1.4
K07-080	80	90	7	10	1.4
K07-090	90	100	7	10	1.4
K07-100	100	110	7	10	1.4
K07-105	105	115	7	10	1.4
K07-130	130	145	9	12	1.8



K07 is a single acting wiper ensuring that foreign particles do not penetrate into the hydraulic systems, avoiding wear and damage to all the internal components including seals

PRODUCT ADVANTAGES

- Superior wiping performance
- Axially open, easy-construction groove
- Used in heavy conditions by the good mechanical properties of PU material.
- Secure seating, press fitting into the housing
- Space-saving construction

APPLICATION

Light and medium duty construction machinery, fork-lift trucks, agricultural machinery, support cylinders and standard cylinders.

MATERIAL		CODE
PU	92 SHORE A	PU9201
STEEL	ST37	FE9901

OPERATING CONDITIONS			
MEDIA	Mineral oils (DIN 51524)	HFA and HFB	HFC
TEMPERATURE	-30°C +100°C	+5°C +50°C	-30°C +40°C
SPEED	≤1.0 m/sec	≤1.0 m/sec	≤1.0 m/sec

Note: The above data are maximum values and cannot be used at the same time.

SURFACE ROUGHNESS		Ra	Rmax
Sliding Surface	Ød	≤0.4 µm	≤3.2 µm
Groove Base	ØD	≤1.6 µm	≤10 µm
Groove Flanks	S1	≤3.2 µm	≤16 µm

INSTALLATION

Wiper is pressed into axially open housings. Special equipment should be used during this process. It is very important that the assembly tools must be of soft material and have no sharp edges. Before installation the wiper must be oiled with system oil.

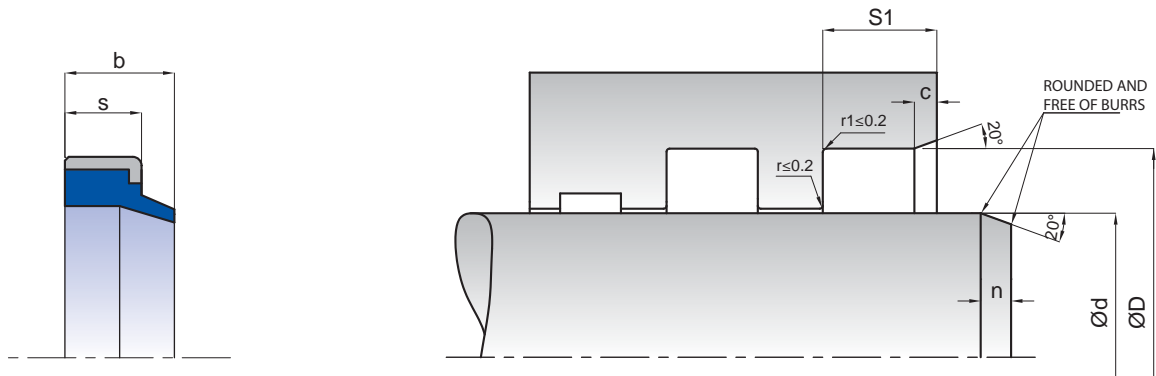

KASTAŞ NO.	d (f8)	D (H8)	s/s1	b	c
K07-020 PU	20	30	7	10	1.4
K07-022 PU	22	32	5	8	1
K07-025 PU	25	35	7	10	1.4
K07-028 PU	28	38	7	10	1.4
K07-030/1 PU	30	40	7	10	1.4
K07-032/2 PU	32	42	7	10	1.4
K07-035 PU	35	45	7	10	1.4
K07-040 PU	40	50	7	10	1.4
K07-045 PU	45	55	7	10	1.4
K07-050 PU	50	60	7	10	1.4
K07-055 PU	55	65	7	10	1.4
K07-060 PU	60	70	7	10	1.4
K07-065 PU	65	75	7	10	1.4
K07-070 PU	70	80	7	10	1.4
K07-075 PU	75	85	7	10	1.4
K07-080 PU	80	90	7	10	1.4
K07-080/1 PU	80	94	8	11	1.6
K07-085 PU	85	99	8	11	1.6
K07-085/1 PU	85	95	7	10	1.4
K07-090 PU	90	100	7	10	1.4
K07-090/1 PU	90	104	8	11	1.6
K07-095 PU	95	105	7	10	1.4
K07-100 PU	100	110	7	10	1.4
K07-130/1 PU	130	146	9	12	1.8



K09 is a single acting wiper ensuring that foreign particles do not penetrate into the hydraulic systems, avoiding wear and damage to all the internal components including seals.

PRODUCT ADVANTAGES

- Very good wiping performance
- No twisting in the housing
- Specially design to prevent big particles to go into the system
- Wide range of dimensions
- Used in heavy conditions by the good mechanical properties of PU material
- Secure seating into the groove

APPLICATION

Construction machinery, forklift-trucks, injection moulding machines, agricultural machinery and standard cylinders.

SURFACE ROUGHNESS

		Ra	Rmax
Sliding Surface	Ød	≤0.4 µm	≤3.2 µm
Groove Base	ØD	≤1.6 µm	≤10 µm
Groove Flanks	S1	≤3.2 µm	≤16 µm

INSTALLATION

Generally, wiper can be easily fitted into the closed housing by deforming into a kidney shape. It is very important that the assembly tools must be of soft material and have no sharp edges. Before installation the wiper must be oiled with system oil.

NOTES

K09 wipers are single acting and can be used with combination of all rod sealing elements. K09 wipers can be produced on request in FKM for special applications that require high temperatures.

MATERIAL		CODE
NBR	90 SHORE A	NB9001
PU	92 SHORE A	PU9201

OPERATING CONDITIONS

NBR			
MEDIA	Mineral oils (DIN 51524)	HFA and HFB	HFC
TEMPERATURE	-30°C +105°C	+5°C +60°C	-30°C +60°C
SPEED	≤1.0 m/sec	≤1.0 m/sec	≤1.0 m/sec

PU			
MEDIA	Mineral oils (DIN 51524)	HFA and HFB	HFC
TEMPERATURE	-30°C +100°C	+5°C +50°C	-30°C +40°C
SPEED	≤1.0 m/sec	≤1.0 m/sec	≤1.0 m/sec

Note: The above data are maximum values and cannot be used at the same time.

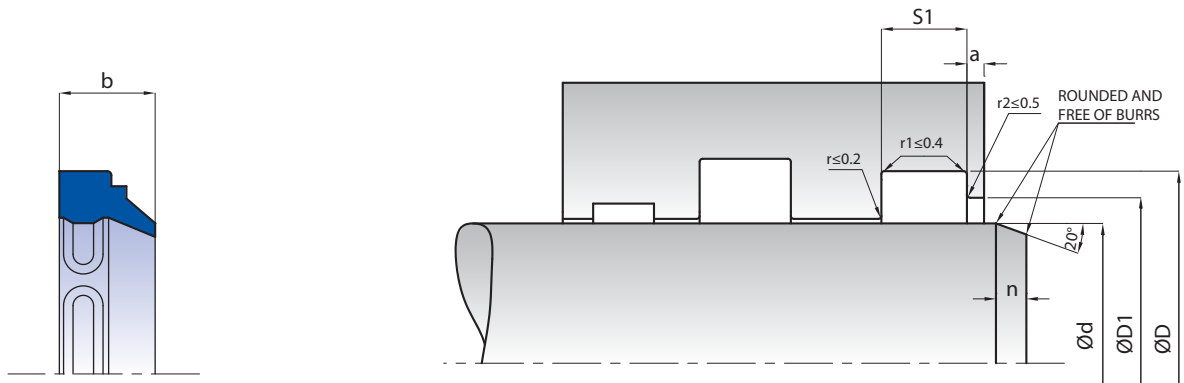

KASTAŞ NO	NBR	PU	d (f8)	D (H10)	D1 (H11)	S1 (-0/+0.2)	a (±0.2)	b
K09-004	NBR		4	12	10	4	1	7
K09-005	NBR		5	8	7	2.2	1	4
K09-006	NBR		6	10	9	2.2	1	4
K09-008	NBR		8	16	14	4	1	7
K09-010	NBR	PU	10	18	16	4	1	7
K09-012/2	NBR		12	18	16	2.6	1	5
K09-012	NBR	PU	12	20	18	4	1	7
K09-014	NBR		14	22	20	4	1	7
K09-015	NBR	PU	15	23	21	4	1	7
K09-016	NBR	PU	16	24	22	4	1	7
K09-017	NBR		17	25	23	4	1	7
K09-018	NBR	PU	18	26	24	4	1	7
K09-020	NBR	PU	20	28	26	4	1	7
K09-022	NBR	PU	22	30	28	4	1	7
K09-022/1	NBR		22	32	30	4	1	7
K09-023	NBR		23	31	29	4	1	7
K09-024	NBR		24	32	30	4	1	7
K09-025	NBR	PU	25	33	31	4	1	7
K09-025/1	NBR	PU	25	35	33	4	1	7
K09-025/2	NBR		25	34	32	5	1	8.5
K09-026	NBR	PU	26	34	32	4	1	7
K09-028	NBR	PU	28	36	34	4	1	7
K09-030	NBR	PU	30	38	36	4	1	7
K09-030/1	NBR		30	40	38	4	1	7
K09-032	NBR	PU	32	40	38	4	1	7
K09-033	NBR		33	41	39	4	1	7
K09-034	NBR	PU	34	42	40	4	1	7
K09-035	NBR	PU	35	43	41	4	1	7
K09-035/1	NBR	PU	35	45	43	4	1	7
K09-036	NBR	PU	36	44	42	4	1	7
K09-038	NBR	PU	38	46	44	4	1	7
K09-040	NBR	PU	40	48	46	4	1	7
K09-040/1	NBR		40	50	48	4	1	7
K09-042	NBR	PU	42	50	48	4	1	7
K09-044	NBR	PU	44	52	50	4	1	7
K09-045	NBR	PU	45	53	51	4	1	7
K09-045/1	NBR		45	56	54	5	1	8
K09-048	NBR		48	56	54	4	1	7
K09-050	NBR	PU	50	58	56	4	1	7
K09-050/1	NBR	PU	50	62	59	5.5	1.5	10
K09-052	NBR	PU	52	60	58	4	1	7
K09-054	NBR		54	62	60	4	1	7
K09-055	NBR	PU	55	63	61	4	1	7
K09-056	NBR	PU	56	64	62	4	1	7
K09-057	NBR	PU	57	65	63	4	1	7
K09-060	NBR	PU	60	68	66	4	1	7
K09-062	NBR		62	70	68	4	1	7
K09-063	NBR	PU	63	71	69	4	1	7
K09-065	NBR	PU	65	73	71	4	1	7

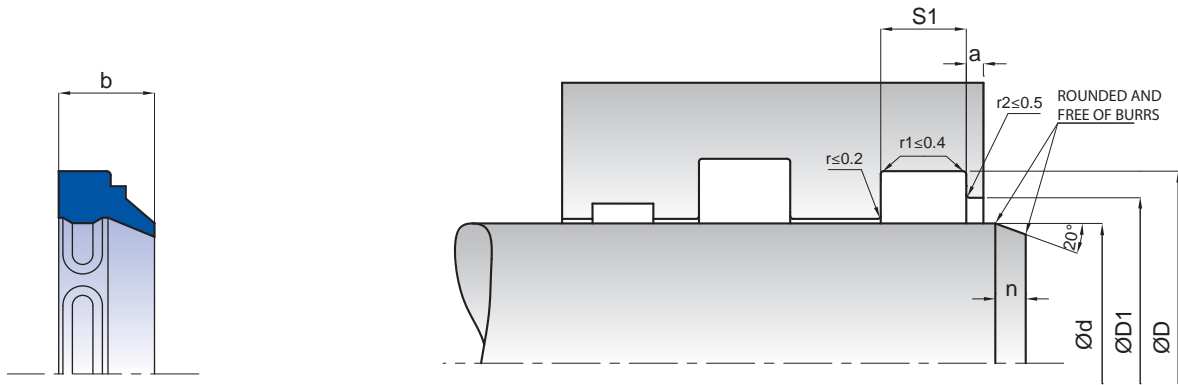

KASTAŞ NO	NBR	PU	d (f8)	D (H10)	D1 (H11)	S1 (-0/+0.2)	a (±0.2)	b
K09-068	NBR		68	76	74	4	1	7
K09-070	NBR	PU	70	78	76	4	1	7
K09-075	NBR	PU	75	83	81	4	1	7
K09-078	NBR		78	86	84	4	1	7
K09-080	NBR	PU	80	88	86	4	1	7
K09-085	NBR	PU	85	93	91	4	1	7
K09-088	NBR		88	96	94	4	1	7
K09-090	NBR	PU	90	98	96	4	1	7
K09-092	NBR		92	100	98	4	1	7
K09-095	NBR		95	103	101	4	1	7
K09-100	NBR	PU	100	108	106	4	1	7
K09-102	NBR		102	114	111	5.5	1.5	10
K09-110	NBR		110	118	116	4	1	7
K09-106		PU	106	118	115	5	1.5	10
K09-110/1	NBR	PU	110	122	119	5.5	1.5	10
K09-115	NBR		115	127	124	5.5	1.5	10
K09-117/1		PU	117	129	126	5.5	1.5	10
K09-120	NBR	PU	120	132	129	5.5	1.5	10
K09-125	NBR		125	137	134	5.5	1.5	10
K09-128	NBR		128	140	137	5.5	1.5	10
K09-130	NBR		130	142	139	5.5	1.5	10
K09-135	NBR		135	147	144	5.5	1.5	10
K09-140	NBR		140	152	149	5.5	1.5	10
K09-150	NBR	PU	150	162	159	5.5	1.5	10
K09-152	NBR		152	164	161	5.5	1.5	10
K09-155	NBR		155	167	164	5.5	1.5	10
K09-160	NBR		160	172	169	5.5	1.5	10
K09-165	NBR		165	177	174	5.5	1.5	10
K09-180	NBR	PU	180	192	189	5.5	1.5	10
K09-190	NBR		190	202	199	5.5	1.5	10
K09-200	NBR		200	212	209	5.5	1.5	10
K09-210	NBR		210	225	222	6.5	1.5	13
K09-210/1	NBR		210	218	216	4	1	7
K09-220	NBR		220	235	232	6.5	1.5	13
K09-250	NBR		250	265	262	6.5	1.5	13



20 horizontal light gray lines for writing.



K10 is a single acting double wiper ensuring that foreign particles are not introduced into the hydraulic cylinders. The lip is designed in a particular way that it reliably wipes off the dirt but leaves a residual oil film on the rod.

PRODUCT ADVANTAGES

- Good scraping effect
- Wide range of dimensions
- No twisting in the housing
- Wiper lip reliably wipes away dirt and leaves a residual oil film on the retracting rod.
- Double lip makes additional protection to prevent the particles to enter into the cylinder
- Easy installation

APPLICATION

Construction machinery, forklift-trucks, injection moulding machines, agricultural machinery and standard cylinders.

MATERIAL		CODE
NBR	90 SHORE A	NB9001

OPERATING CONDITIONS			
MEDIA	Mineral oils (DIN 51524)	HFA and HFB	HFC
TEMPERATURE	-30°C +105°C	+5°C +60°C	-30°C +60°C
SPEED	≤1.0 m/sec	≤1.0 m/sec	≤1.0 m/sec

Note: The above data are maximum values and cannot be used at the same time.

SURFACE ROUGHNESS		Ra	Rmax
Sliding Surface	Ød	≤0.3 µm	≤3.2 µm
Groove Base	ØD	≤1.8 µm	≤10 µm
Groove Flanks	S1	≤3 µm	≤16 µm

INSTALLATION

Generally, wiper can be easily fitted into the closed housing by deforming into a kidney shape. It is very important that the assembly tools must be of soft material and have no sharp edges. Before installation the wiper must be oiled with system oil.

NOTES

K10 double wiper should be used in combination of suitable rod seals to avoid hydrodynamic pressure or pressure relieving bore between seal and wiper should be constructed to prevent the build up pressures (See section; Hydraulic Sealing Elements - Sample Designs). K10 wipers can be produced on request in FKM for special applications that require high temperatures.

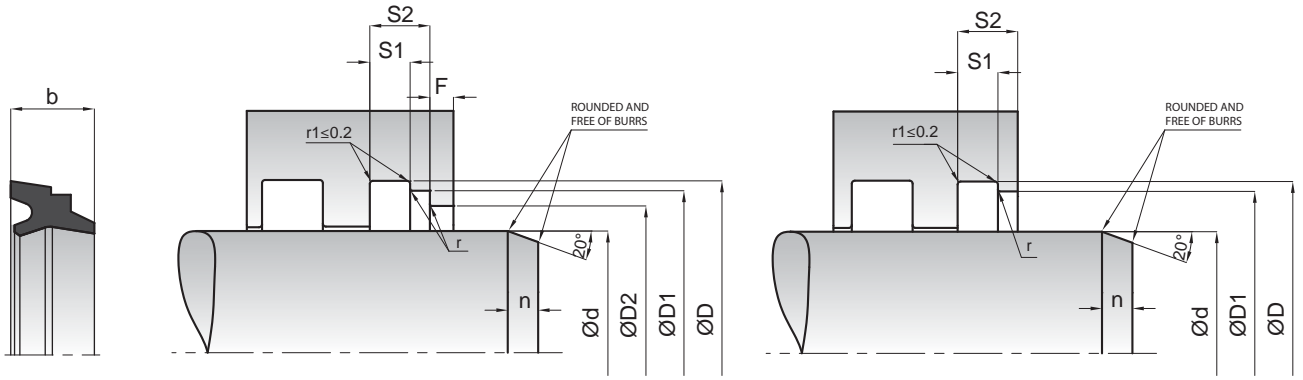

KASTAŞ NO	d (f8)	D (H10)	D1 (H9)	D2 (H10)	S1 (-0/+0.2)	S2 (-0/+0.2)	F ≥	b	r
K10-010	10	18	16	13.5	4	6	2	8	0.5
K10-012	12	20	18	15.5	4	6	2	8	0.5
K10-014	14	22	20	17.5	4	6	2	8	0.5
K10-015	15	23	21	18.5	4	6	2	8	0.5
K10-016	16	24	22	19.5	4	6	2	8	0.5
K10-018	18	26	24	21.5	4	6	2	8	0.5
K10-020	20	28	26	23.5	4	6	2	8	0.5
K10-022	22	30	28	25.5	4	6	2	8	0.5
K10-024	24	32	30	27.5	4	6	2	8	0.5
K10-025	25	33	31	28.5	4	6	2	8	0.5
K10-026	26	34	32	29.5	4	6	2	8	0.5
K10-028	28	36	34	31.5	4	6	2	8	0.5
K10-030	30	38	36	33.5	4	6	2	8	0.5
K10-032	32	40	38	35.5	4	6	2	8	0.5
K10-035	35	43	41	38.5	4	6	2	8	0.5
K10-036	36	44	42	39.5	4	6	2	8	0.5
K10-037	37	45	43	40.5	4	6	2	8	0.5
K10-038	38	46	44	41.5	4	6	2	8	0.5
K10-040	40	48	46	43.5	4	6	2	8	0.5
K10-042	42	50	48	45.5	4	6	2	8	0.5
K10-045	45	53	51	48.5	4	6	2	8	0.5
K10-046	46	54	52	49.5	4	6	2	8	0.5
K10-048	48	56	54	51.5	4	6	2	8	0.5
K10-050	50	58	56	53.5	4	6	2	8	0.5
K10-052	52	60	58	55.5	4	6	2	8	0.5
K10-055	55	63	61	58.5	4	6	2	8	0.5
K10-056	56	64	62	59.5	4	6	2	8	0.5
K10-060	60	68	66	63.5	4	6	2	8	0.5
K10-063	63	71	69	66.5	4	6	2	8	0.5
K10-065	65	73	71	68.5	4	6	2	8	0.5
K10-068	68	76	74	71.5	4	6	2	8	0.5
K10-070	70	78	76	73.5	4	6	2	8	0.5
K10-075	75	83	81	78.5	4	6	2	8	0.5
K10-080	80	88	86	83.5	4	6	2	8	0.5
K10-085	85	93	91	88.5	4	6	2	8	0.5
K10-090	90	98	96	93.5	4	6	2	8	0.5
K10-095	95	103	101	98.5	4	6	2	8	0.5
K10-100	100	108	106	103.5	4	6	2	8	0.5
K10-105	105	117	114	110	5.5	8.2	3	11	1
K10-110	110	122	119	115	5.5	8.2	3	11	1
K10-113	113	125	122	118	5.5	8.2	3	11	1
K10-115	115	127	124	120	5.5	8.2	3	11	1
K10-120	120	132	129	125	5.5	8.2	3	11	1
K10-125	125	137	134	130	5.5	8.2	3	11	1
K10-130	130	142	139	135	5.5	8.2	3	11	1
K10-135	135	147	144	140	5.5	8.2	3	11	1
K10-140	140	152	149	145	5.5	8.2	3	11	1
K10-142	142	154	151	147	5.5	8.2	3	11	1
K10-145	145	157	154	150	5.5	8.2	3	11	1

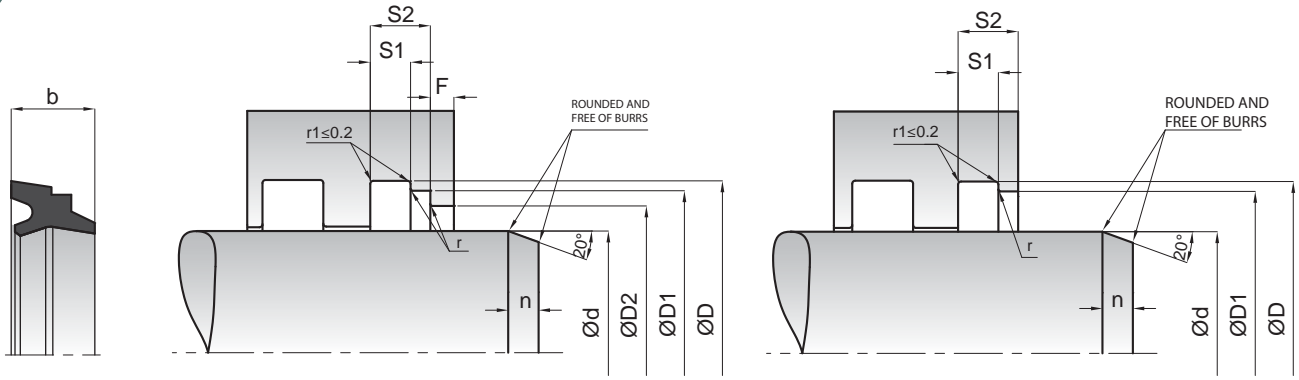

KASTAŞ NO	d (f8)	D (H10)	D1 (H9)	D2 (H10)	S1 (-0/+0.2)	S2 (-0/+0.2)	F ≥	b	r
K10-150	150	162	159	155	5.5	8.2	3	11	1
K10-155	155	167	164	160	5.5	8.2	3	11	1
K10-160	160	172	169	165	5.5	8.2	3	11	1
K10-165	165	177	174	170	5.5	8.2	3	11	1
K10-170	170	182	179	175	5.5	8.2	3	11	1
K10-172	172	184	181	177	5.5	8.2	3	11	1
K10-175	175	187	184	180	5.5	8.2	3	11	1
K10-180	180	192	189	185	5.5	8.2	3	11	1
K10-185	185	197	194	190	5.5	8.2	3	11	1
K10-190	190	202	199	195	5.5	8.2	3	11	1
K10-192	192	204	201	197	5.5	8.2	3	11	1
K10-195	195	207	204	200	5.5	8.2	3	11	1
K10-200	200	212	209	205	5.5	8.2	3	11	1
K10-205	205	220	216	212	6.4	9.5	3	13	1
K10-210	210	225	221	217	6.4	9.5	3	13	1
K10-215	215	230	227	222	6.4	9.5	3	13	1
K10-220	220	235	231	227	6.4	9.5	3	13	1
K10-225	225	240	236	232	6.4	9.5	3	13	1
K10-230	230	245	241	237	6.4	9.5	3	13	1
K10-235	235	250	247	242	6.4	9.5	3	13	1
K10-240	240	255	251	247	6.4	9.5	3	13	1
K10-245	245	260	257	252	6.4	9.5	3	13	1
K10-250	250	265	261	257	6.4	9.5	3	13	1
K10-258	258	273	270	265	6.4	9.5	3	13	1
K10-260	260	275	271	267	6.4	9.5	3	13	1
K10-270	270	285	282	277	6.4	9.5	3	13	1
K10-275	275	290	286	282	6.4	9.5	3	13	1
K10-280	280	295	291	287	6.4	9.5	3	13	1
K10-285	285	300	297	292	6.4	9.5	3	13	1
K10-290	290	305	301	297	6.4	9.5	3	13	1
K10-300	300	315	311	307	6.4	9.5	3	13	1
K10-310	310	325	321	317	6.4	9.5	3	13	1
K10-320	320	335	331	327	6.4	9.5	3	13	1
K10-340	340	355	352	347	6.4	9.5	3	13	1
K10-345	345	360	357	352	6.4	9.5	3	13	1
K10-350	350	365	361	357	6.4	9.5	3	13	1
K10-360	360	375	371	367	6.4	9.5	3	13	1
K10-370	370	385	381	377	6.4	9.5	3	13	1
K10-400	400	415	412	407	6.4	9.5	3	13	1
K10-450	450	465	462	457	6.4	9.5	3	13	1
K10-460	460	475	472	467	6.4	9.5	3	13	1



20 horizontal light gray lines for writing.



K11 is a single acting scrapper ensuring that foreign particles do not penetrate into the hydraulic cylinders, avoiding wear and damage to all the internal components including seals.

PRODUCT ADVANTAGES

- Superior scraping effect
- Simple, easy-construction groove
- No twisting in the housing
- Design in a way that the wiping lip contacts with the rod surface to remove heavily deposited mud, ice, etc so that the particles do not enter into the cylinder
- Outside diameter contacts the housing and has a sealing lip to prevent moisture entering the groove.

APPLICATION

Especially used in heavy construction machinery that operate in the open field, telescopic cylinders, cranes, mining equipment and loading platforms.

MATERIAL	CODE
TPE	TP7301

OPERATING CONDITIONS			
MEDIA	Mineral oils (DIN 51524)	HFA and HFB	HFC
TEMPERATURE	-40°C +120°C	+5°C +60°C	-30°C +60°C
SPEED	≤2.0 m/sec	≤2.0 m/sec	≤2.0 m/sec

Note: The above data are maximum values and cannot be used at the same time.

SURFACE ROUGHNESS		Ra	Rmax
Sliding Surface	Ød	≤0.4 µm	≤3.2 µm
Groove Base	ØD	≤1.6 µm	≤10 µm
Groove Flanks	S1	≤3.2 µm	≤16 µm

INSTALLATION

Open housing is recommended but closed grooves can be used for wipers bigger than 40 mm inner diameter. It is very important that the assembly tools must be of soft material and have no sharp edges. Before installation the wiper must be oiled with system oil.

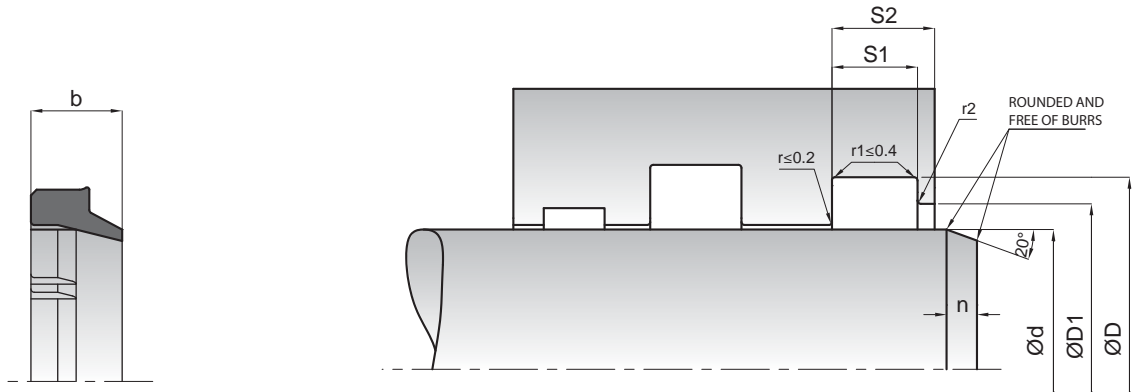

KASTAŞ NO	Ød (f8)	ØD (H11)	ØD1 (H11)	S1 (-0/+0.2)	S2	b	r2
K11-020	20	28	25.5	5	8	8	0.2
K11-025	25	33	30.5	5	8	8	0.2
K11-028	28	36	33.5	5	8	8	0.2
K11-030	30	38	35.5	5	8	8	0.2
K11-032	32	40	37.5	5	8	8	0.2
K11-035	35	43	40.5	5	8	8	0.2
K11-038	38.1	47.62	44.45	4.76	7.15	7.15	0.2
K11-040	40	48	45.5	5	8	8	0.2
K11-044	44.45	53.97	50.67	4.76	7.15	7.15	0.2
K11-045	45	55.6	48	5.3	7	7	0.2
K11-045/1	45	53	50.5	5	8	8	0.2
K11-048	48	60	55	5	10	10	0.2
K11-050/2	50	58	55.5	5	8	8	0.2
K11-050/1	50	58.6	53	5.3	7	9	0.2
K11-050	50	60.6	53	5.3	7	7	0.2
K11-055	55	65.6	58	5.3	7	7	0.4
K11-056	56	66	62	6	9	9	0.4
K11-060	60	70	66	6	9	9	0.4
K11-060/3	60	70	66	5.3	7	7	0.4
K11-063	63	73.6	66	5	7	7	0.4
K11-063/1	63.5	76.12	70.2	6.35	9.52	9.52	0.4
K11-065	65	75	72	6.3	10	10	0.4
K11-070	70	80	76	6	9	9	0.4
K11-070/1	70	80.6	73	5.3	7	7	0.4
K11-075	75	87.2	81	7.2	12	12	0.4
K11-080	80	90	86	6	9	9	0.4
K11-080/1	80	92.2	86	7.2	12	12	0.4
K11-085	85	98	92	7.5	11.5	11.5	0.4
K11-090	90	100	96	6	9	9	0.6
K11-090/1	90	102.2	96	7.2	12	12	0.6
K11-095	95	107.2	101	7.2	12	12	0.6
K11-100	100	112.2	106	7.2	12	12	0.6
K11-110	110	125	120	9.5	14	14	0.6
K11-114	114.3	133.35	123.45	9.52	14.27	14.27	0.6
K11-115	115	127.2	121	7.2	12	12	0.6
K11-120	120	132.2	126	7.2	12	12	0.6
K11-125	125	140	135	9.5	14	14	0.6
K11-140/1	140	155	147.5	10.2	16	16	0.6
K11-140	140	155	150	9.5	14	14	0.6
K11-150	150	165	158.6	10.2	12	12	0.6
K11-160	160	175	167	10.2	16	16	0.6
K11-180	180	200	190	10.2	18	18	0.6
K11-195	195	210	202.5	10.2	16	16	0.6
K11-200	200	220	210	10.2	18	18	0.8
K11-210	210	230	220	10.2	18	18	0.8
K11-220	220	240	233.5	12.5	18	18	0.8
K11-240	240	260	250	10.2	18	18	0.8
K11-260	260	280	270.5	10.2	18	18	0.8
K11-290	290	310	300	10.2	18	18	0.8



20 horizontal light gray lines for writing.



K12 is a single acting double wiper ensuring that foreign particles do not penetrate into the hydraulic systems by their lip design, avoiding wear and damage to all the internal components including seals.

PRODUCT ADVANTAGES

- Superior wiping performance
- Axially open, easy-construction groove
- Used in heavy conditions by the good mechanical properties of Polyurethane.
- Wiper lip reliably wipes away dirt and leaves a residual oil film on the retracting rod.
- Space-saving design
- Double lip makes additional protection to prevent the particles to enter into the cylinder

APPLICATION

Construction machinery, fork-lift trucks, agricultural machinery, support cylinders and standard cylinders.

MATERIAL		CODE
PU	95 SHORE A	PU9501
STEEL	ST37	FE9901

OPERATING CONDITIONS

MEDIA	Mineral oils (DIN 51524)	HFA and HFB	HFC
TEMPERATURE	-30°C +100°C	+5°C +50°C	-30°C +40°C
SPEED	≤1.0 m/sec	≤1.0 m/sec	≤1.0 m/sec

Note: The above data are maximum values and cannot be used at the same time.

SURFACE ROUGHNESS		Ra	Rmax
Sliding Surface	Ød	≤0.4 µm	≤3.2 µm
Groove Base	ØD	≤1.6 µm	≤10 µm
Groove Flanks	S1	≤3.2 µm	≤16 µm

INSTALLATION

Wiper is pressed into axially open housings. Special equipment should be used during this process. It is very important that the assembly tools must be of soft material and have no sharp edges. Before installation the wiper must be oiled with system oil.



K27 is a single acting double wiper ensuring that foreign particles do not penetrate into the hydraulic cylinders. The lip is designed in a particular way that it reliably wipes off the dirt but leaves a residual oil film on the rod.

PRODUCT ADVANTAGES

- Good wiping effect
- Wide range of dimensions
- No twisting in the housing
- Wiper lip reliably wipes away dirt and leaves a residual oil film on the retracting rod.
- Double lip makes additional protection to prevent the particles to enter into the cylinder
- Easy installation

APPLICATION

Construction machinery, fork-lift trucks, injection moulding machines, agricultural machinery and standard cylinders.

MATERIAL		CODE
NBR	90 SHORE A	NB9001
PU	92 SHORE A	PU9201

OPERATING CONDITIONS

NBR			
MEDIA	Mineral oils (DIN 51524)	HFA and HFB	HFC
TEMPERATURE	-30°C +105°C	+5°C +60°C	-30°C +60°C
SPEED	≤1.0 m/sec	≤1.0 m/sec	≤1.0 m/sec

PU			
MEDIA	Mineral oils (DIN 51524)	HFA and HFB	HFC
TEMPERATURE	-30°C +100°C	+5°C +50°C	-30°C +40°C
SPEED	≤1.0 m/sec	≤1.0 m/sec	≤1.0 m/sec

Note: The above data are maximum values and cannot be used at the same time.

SURFACE ROUGHNESS		Ra	Rmax
Sliding Surface	Ød	≤0.4 µm	≤3.2 µm
Groove Base	ØD	≤1.6 µm	≤10 µm
Groove Flanks	S1	≤3 µm	≤16 µm

INSTALLATION

Generally, wiper can be easily fitted into the closed housing by deforming into a kidney shape. It is very important that the assembly tools must be of soft material and have no sharp edges. Before installation the wiper must be oiled with system oil.

NOTES

K27 double wiper should be used in combination of suitable rod seals to avoid hydrodynamic pressure or pressure relieving bore between seal and wiper should be constructed to prevent the build up pressures (See section; Hydraulic Sealing Elements - Sample Designs). K27 wipers can be produced on request in FKM for special applications that require high temperatures.

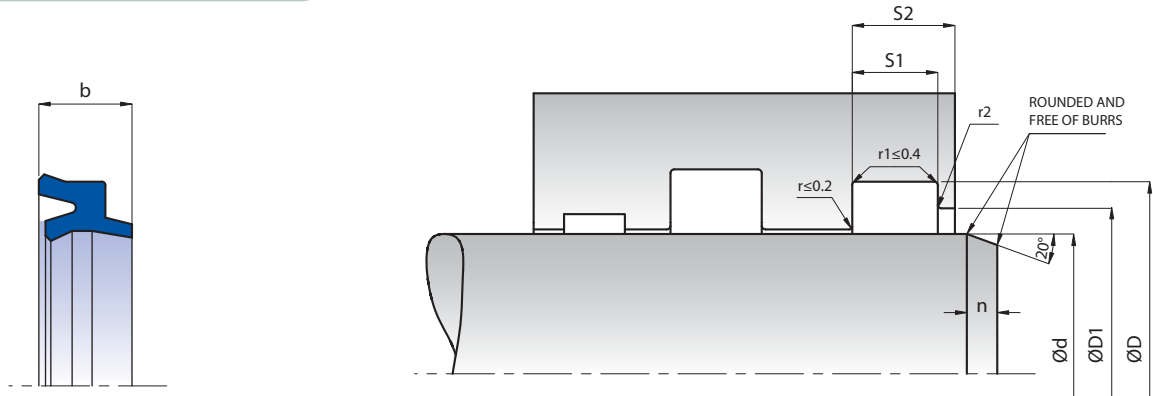

KASTAŞ NO	NBR	PU	d (f8)	D (H10)	D1 (H11)	S1 (-0/+0.2)	S2	b	r2
K27-016	NBR		16	22	19	3.8	5.8	5.5	0.5
K27-020	NBR	PU	20	28.6	23	5.3	7.3	7	1
K27-025	NBR	PU	25	33.6	28	5.3	7.3	7	1
K27-028	NBR	PU	28	36.6	31	5.3	7.3	7	1
K27-030	NBR	PU	30	38.6	33	5.3	7.3	7	1
K27-035	NBR	PU	35	43.6	38	5.3	7.3	7	1
K27-036	NBR	PU	36	44.6	39	5.3	7.3	7	1
K27-040	NBR	PU	40	48.6	43	5.3	7.3	7	1
K27-045	NBR	PU	45	55.6	48	5.3	7.3	7	1
K27-050	NBR	PU	50	60.6	53	5.3	7.3	7	1
K27-050/2	NBR	PU	50	58.6	53	5.3	7.3	7	1
K27-055	NBR	PU	55	65.6	58	5.3	7.3	7	1
K27-060	NBR	PU	60	70.6	63	5.3	7.3	7	1
K27-063	NBR	PU	63	71.6	66	5.3	7.3	7	1
K27-063/1	NBR	PU	63	73.6	66	5.3	7.3	7	1
K27-065	NBR	PU	65	75.6	68	5.3	7.3	7	1
K27-070	NBR	PU	70	80.6	73	5.3	7.3	7	1
K27-075	NBR	PU	75	87.2	81	7.1	9.1	12	1
K27-080	NBR	PU	80	92.2	86	7.1	9.1	12	1
K27-085	NBR	PU	85	97.2	91	7.1	9.1	12	1
K27-090	NBR	PU	90	102.2	96	7.1	9.1	12	1
K27-095	NBR	PU	95	107.2	101	7.1	9.1	12	1
K27-115	NBR	PU	115	127.2	121	7.1	9.1	12	1
K27-125	NBR	PU	125	140.2	110	7.6	9.6	9.5	1
K27-135	NBR	PU	135	147.2	141	7.1	9.1	12	1
K27-155	NBR	PU	155	167.2	161	7.1	9.1	12	1
K27-160	NBR	PU	160	172.2	166	7.1	9.1	12	1
K27-185	NBR	PU	185	197.2	191	7.1	9.1	12	1
K27-215	NBR	PU	215	227.2	221	7.1	9.1	12	1
K27-240	NBR	PU	240	255.2	247	7.1	9.1	12	1
K27-280	NBR		280	305	292	15.8	17.8	22.5	1



K703 is a two piece single acting wiper which consists of one special designed PTFE profile ring and an o-ring as energizing element. K703 ensures that foreign particles do not penetrate into the hydraulic systems, avoiding wear and damage to all the internal components including seals.

PRODUCT ADVANTAGES

- Low friction, free of stick-slip
- Long service life
- High sliding speed
- Space-saving construction
- Wide range of temperature and chemicals depending on the o-ring material
- Wide range of dimensions

APPLICATION

Mobile hydraulics, aluminum injection machines and industrial equipment.

MATERIAL		CODE
NBR	70 SHORE A	NB7001
PTFE		PT6003

OPERATING CONDITIONS			
MEDIA	Mineral oils (DIN 51524)	HFA and HFB	HFC
TEMPERATURE	-30°C +105°C	+5°C +60°C	-30°C +60°C
SPEED	≤5.0 m/sec	≤5.0 m/sec	≤5.0 m/sec

Note: The above data are maximum values and cannot be used at the same time.

SURFACE ROUGHNESS		Ra	Rmax
Sliding Surface	Ød	≤0.4 µm	≤3.2 µm
Groove Base	ØD	≤1.6 µm	≤6.3 µm
Groove Flanks	B	≤3.2 µm	≤16 µm

Note: It is recommended to have 50% to 90% of the working surface material contact area value

INSTALLATION

We recommend using special assembly tool (See section; Hydraulic Sealing Elements General Installation Information). It is very important that the assembly tools must be of soft material and have no sharp edges. Before installation the sealing element must be oiled with system oil.

NOTES

When K703 wiper is being used with double lip sealing element we recommend a pressure relieving bore between the seal and wiper. For special applications that require high temperatures or resistance to chemicals, piston seal can be manufactured with special mixture PTFE and FKM.

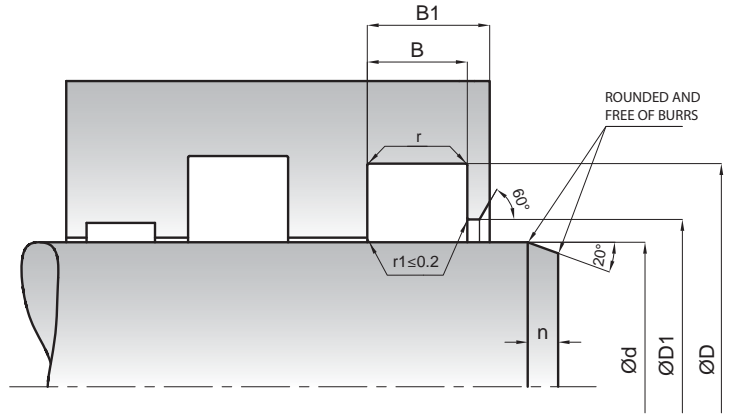
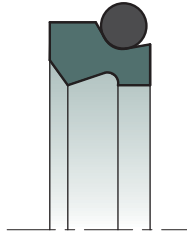

KASTAŞ NO	d (f8)	D (H9)	D1 (H11)	B (-0/+0.2)	B1	r	O-Ring
K703-020	20	27.6	21.5	4.2	7.2	0.8	21.89x2.62
K703-028	28	35.6	29.5	4.2	7.2	0.8	29.82x2.62
K703-030	30	37.6	31.5	4.2	7.2	0.8	32.99x2.62
K703-032	32	39.6	33.5	4.2	7.2	0.8	34.59x2.62
K703-036/1	36	43.6	37.5	4.2	7.2	0.8	37.77x2.62
K703-040	40	48.8	41.5	6.3	9.3	0.8	44.12x2.62
K703-042	42	49.6	43.5	4.2	7.2	0.8	44.12x2.62
K703-045	45	53.8	46.5	6.3	9.3	0.8	48.90x2.62
K703-050	50	58.8	51.5	6.3	9.3	0.8	53.64x2.62
K703-055	55	63.8	56.5	6.3	9.3	0.8	58.42x2.62
K703-056	56	64.8	57.5	6.3	9.3	0.8	59.99x2.62
K703-060	60	68.8	61.5	6.3	9.3	0.8	63.17x2.62
K703-063	63	71.8	64.5	6.3	9.3	0.8	66.34x2.62
K703-065	65	73.8	66.5	6.3	9.3	0.8	67.95x2.62
K703-070	70	82.2	72	8.1	12.1	1	75.79x3.53
K703-075	75	87.2	77	8.1	12.1	1	78.97x3.53
K703-080	80	92.2	82	8.1	12.1	1	85.32x3.53
K703-085	85	97.2	87	8.1	12.1	1	88.49x3.53
K703-090	90	102.2	92	8.1	12.1	1	94.84x3.53
K703-100	100	112.2	102	8.1	12.1	1	104.37x3.53
K703-105	105	117.2	107	8.1	12.1	1	110.72x3.53
K703-110	110	122.2	112	8.1	12.1	1	113.89x3.53
K703-115	115	127.2	117	8.1	12.1	1	120.24x3.53
K703-120	120	132.2	122	8.1	12.1	1	123.42x3.53
K703-125	125	137.2	127	8.1	12.1	1	129.77x3.53
K703-130	130	142.2	132	8.1	12.1	1	136.12x3.53
K703-135	135	147.2	137	8.1	12.1	1	139.29x3.53
K703-140	140	156	142.5	9.5	14.5	1.5	145.42x5.33
K703-150	150	166	152.5	9.5	14.5	1.5	151.77x5.33
K703-160	160	176	162.5	9.5	14.5	1.5	164.47x5.33
K703-165	165	181	167.5	9.5	14.5	1.5	170.82x5.33
K703-170	170	186	172.5	9.5	14.5	1.5	177.17x5.33
K703-180	180	196	182.5	9.5	14.5	1.5	183.52x5.33
K703-190	190	206	192.5	9.5	14.5	1.5	196.22x5.33
K703-200	200	216	202.5	9.5	14.5	1.5	202.57x5.33
K703-220	220	236	222.5	9.5	14.5	1.5	221.62x5.33
K703-240	240	256	242.5	9.5	14.5	1.5	247.02x5.33
K703-250	250	266	252.5	9.5	14.5	1.5	253.57x5.33
K703-260	260	276	262.5	9.5	14.5	1.5	266.07x5.33
K703-270	270	286	272.5	9.5	14.5	1.5	278.77x5.33
K703-280	280	296	282.5	9.5	14.5	1.5	278.77x5.33
K703-300	300	316	302.5	9.5	14.5	1.5	304.17x5.33
K703-320	320	336	322.5	9.5	14.5	1.5	329.57x5.33
K703-330	330	346	332.5	9.5	14.5	1.5	329.57x5.33
K703-350	350	366	352.5	9.5	14.5	1.5	354.97x5.33
K703-380	380	396	382.5	9.5	14.5	1.5	380.37x5.33
K703-480	480	504	482.5	14	22	1.5	481.46x6.99
K703-500	500	524	502.5	14	22	1.5	506.86x6.99



20 horizontal light gray lines for writing.



SPECIAL SEALING ELEMENTS



Lined writing area consisting of 25 horizontal light gray bars.

SPECIAL SEALING ELEMENTS

SEAL PROGRAMME

KASTAŞ CODE	PRODUCT NAME	DRAWING	APPLICATION	MATERIAL	CODE	PRESSURE (max) bar	TEMPERATURE (max) °C	SLIDING SPEED (max) - m/sn	PAGE NO
K14	V-Ring			NBR	NB7001	0.3	-30/+105	12.0 Peripheral	192
K150	Chevron Ring		Rod	FABRIC NBR	NB8503	250	-30/+80	2.0	196
K151	High Pressure Chevron Seal		Rod	FABRIC NBR POM PTFE	NB8503 PM9901 PT6002	250	-30/+80	2.0	198
K152/ K153	Low Pressure Chevron Seal		Rod	FABRIC NBR POM	NB8503 PM9901	80	-30/+80	2.0	200
K702	Rod Seal for Rotating Application		Rod	NBR PTFE	NB7001 PT6003	300	-30/+105	5.0 Peripheral	202
K752	Piston Seal for Rotating Application		Piston	NBR PTFE	NB7001 PT6003	300	-30/+105	5.0 Peripheral	204



K14 is a V-Ring designed to be used for rotating shaft applications.

PRODUCT ADVANTAGES

- Easy fitting and requires little space
- Functions even with poor surfaces
- The one size of V-seal can be used for shafts of several different diameters
- Low friction
- Economical sealing solution

APPLICATION

Limit switches of electric motors, agricultural machinery, automotive engineering and special applications of rotating systems.

MATERIAL		CODE
NBR	70 SHORE A	NB7001

OPERATING CONDITIONS		
MEDIA	Water and Steam	Greases
TEMPERATURE	+5°C	-30°C
	+105°C	+105°C
PRESSURE	0.3 Bar	0.3 Bar
PERIPHERAL SPEED	≤12.0 m/sec	≤12.0 m/sec

Note: The above data are maximum values and cannot be used at the same time.

SURFACE ROUGHNESS	Ra	Rmax
Sliding Surface	≤0.8 μm	≤3 μm
Groove Base	≤1.8 μm	≤6.3 μm
Groove Flanks	≤5 μm	≤18 μm

INSTALLATION

Assembly of the v-ring is easy and does not require much time. The ring is expanded and pulled over the shaft. It is then brought into position with a rounded screw-driver or similar tool. It is very important that the assembly tools must be of soft material and have no sharp edges. Before installation the sealing element must be oiled with system oil.

NOTES

For special applications that require high temperatures, V-rings can be produced in FKM.

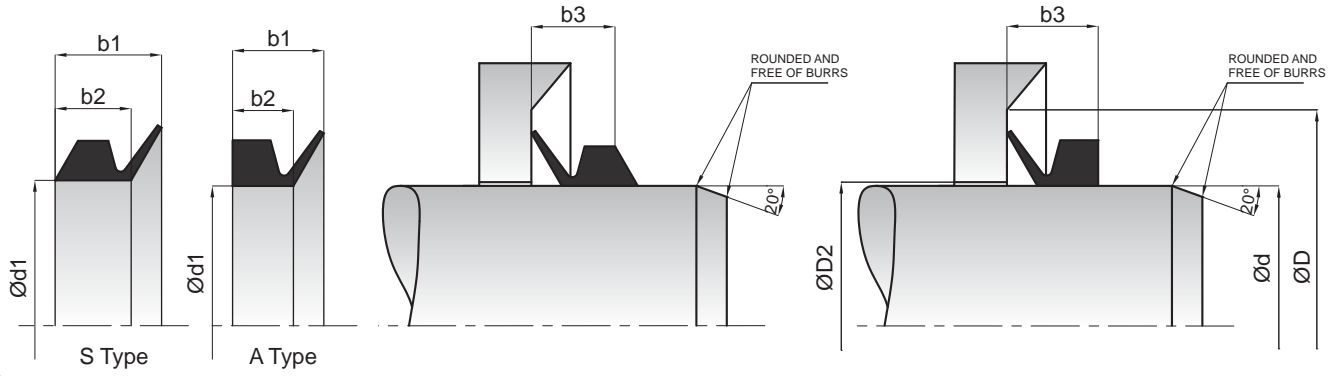

KASTAŞ NO	d	D min	Ød1	b1	b2	b3	D2 max.
K14-010 A	9.5-11.5	d+9	9	5.5	3.4	4.5±0.6	d+2
K14-010 S	9.5-11.5	d+9	9	7.7	5.6	6.7±0.6	d+2
K14-012 A	11.5-13.5	d+9	10.5	5.5	3.4	4.5±0.6	d+2
K14-012 S	11.5-13.5	d+9	10.5	7.7	5.6	6.7±0.6	d+2
K14-014 A	13.5-15.5	d+9	12.5	5.5	3.4	4.5±0.6	d+2
K14-014 S	13.5-15.5	d+9	12.5	7.7	5.6	6.7±0.6	d+2
K14-016 A	15.5-17.5	d+9	14	5.5	3.4	4.5±0.6	d+2
K14-016 S	15.5-17.5	d+9	14	7.7	5.6	6.7±0.6	d+2
K14-018 A	17.5-19	d+9	16	5.5	3.4	4.5±0.6	d+2
K14-018 S	17.5-19	d+9	16	7.7	5.6	6.7±0.6	d+2
K14-020 A	19-21	d+12	18	7.5	4.7	6.0±0.8	d+2
K14-020 S	19-21	d+12	18	10.5	7.9	9.0±0.8	d+2
K14-025 A	24-27	d+12	22	7.5	4.7	6.0±0.8	d+2
K14-025 S	24-27	d+12	22	10.5	7.9	9.0±0.8	d+2
K14-030 A	29-31	d+12	27	7.5	4.7	6.0±0.8	d+3
K14-030 S	29-31	d+12	27	10.5	7.9	9.0±0.8	d+3
K14-032 A	31-33	d+12	29	7.5	4.7	6.0±0.8	d+3
K14-032 S	31-33	d+12	29	10.5	7.9	9.0±0.8	d+3
K14-035 A	33-36	d+12	31	7.5	4.7	6.0±0.8	d+3
K14-035 S	33-36	d+12	31	10.5	7.9	9.0±0.8	d+3
K14-038 A	36-38	d+12	34	7.5	4.7	6.0±0.8	d+3
K14-038 S	36-38	d+12	34	10.5	7.9	9.0±0.8	d+3
K14-040 A	38-43	d+12	36	9	5.5	7.0±1.0	d+3
K14-040 S	38-43	d+15	36	13	9.5	11.0±1.0	d+3
K14-045 A	43-48	d+15	40	9	5.5	7.0±1.0	d+3
K14-045 S	43-48	d+15	40	13	9.5	11.0±1.0	d+3
K14-050 A	48-53	d+15	45	9	5.5	7.0±1.0	d+3
K14-050 S	48-53	d+15	45	13	9.5	11.0±1.0	d+3
K14-055 A	53-58	d+15	49	9	5.5	7.0±1.0	d+3
K14-055 S	53-58	d+15	49	13	9.5	11.0±1.0	d+3
K14-060 A	58-63	d+15	54	9	5.5	7.0±1.0	d+3
K14-060 S	58-63	d+15	54	13	9.5	11.0±1.0	d+3
K14-065 A	63-68	d+15	58	9	5.5	7.0±1.0	d+3
K14-065 S	63-68	d+15	58	13	9.5	11.0±1.0	d+3
K14-070 A	68-73	d+18	63	11	6.8	9.0±1.2	d+4
K14-070 S	68-73	d+18	63	15.5	11.3	13.5±1.2	d+4
K14-075 A	73-78	d+18	67	11	6.8	9.0±1.2	d+4
K14-075 S	73-78	d+18	67	15.5	11.3	13.5±1.2	d+4
K14-080 A	78-83	d+18	72	11	6.8	9.0±1.2	d+4
K14-080 S	78-83	d+18	72	15.5	11.3	13.5±1.2	d+4
K14-085 A	83-88	d+18	76	11	6.8	9.0±1.2	d+4
K14-085 S	83-88	d+18	76	15.5	11.3	13.5±1.2	d+4
K14-090 A	88-93	d+18	81	11	6.8	9.0±1.2	d+4
K14-090 S	88-93	d+18	81	15.5	11.3	13.5±1.2	d+4
K14-095 A	93-98	d+18	85	11	6.8	9.0±1.2	d+4
K14-095 S	93-98	d+18	85	15.5	11.3	13.5±1.2	d+4
K14-100 A	98-105	d+18	90	11	6.8	9.0±1.2	d+4
K14-100 S	98-105	d+18	90	15.5	11.3	13.5±1.2	d+4
K14-110 A	105-115	d+21	99	12.8	7.9	10.5±1.5	d+4

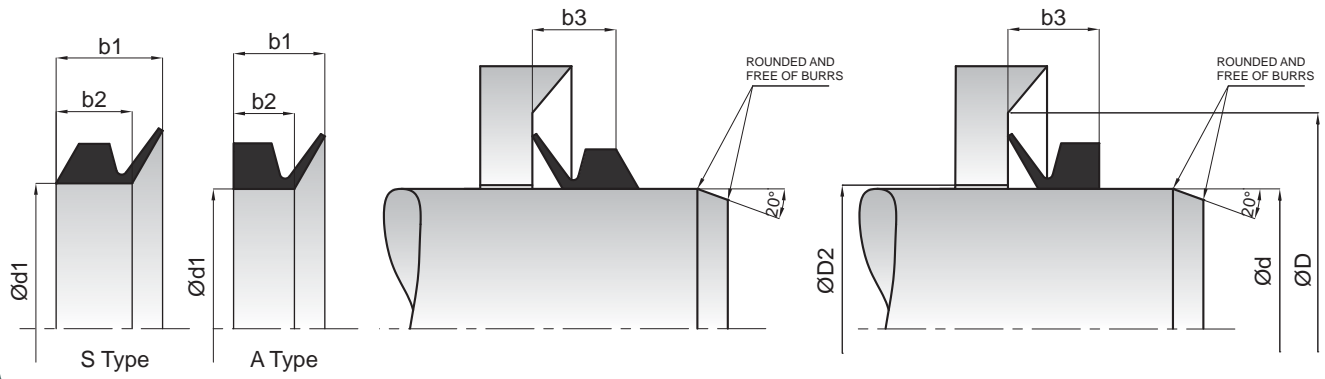

KASTAŞ NO	d	D min	Ød1	b1	b2	b3	D2 max.
K14-110 S	105-115	d+21	99	18	13.1	15.5±1.5	d+4
K14-120 A	115-125	d+21	108	12.8	7.9	10.5±1.5	d+4
K14-120 S	115-125	d+21	108	18	13.1	15.5±1.5	d+4
K14-130 A	125-135	d+21	117	12.8	7.9	10.5±1.5	d+4
K14-130 S	125-135	d+21	117	18	13.1	15.5±1.5	d+4
K14-140 A	135-145	d+21	126	12.8	7.9	10.5±1.5	d+4
K14-140 S	135-145	d+21	126	18	13.1	15.5±1.5	d+4



20 horizontal light gray lines for writing.



K150 is a single acting chevron ring specially designed to work in water, water-oil mixtures and produced from special formulated reinforced cotton fabric with nitrile rubber.

PRODUCT ADVANTAGES

- Capable of standing pressure changes
- Long service life
- Works in water and water-oil mixture media
- Adjustable housing

APPLICATION

Mining and high pressure cleaning equipment.

MATERIAL	CODE
COTTON FABRIC NBR	NB8503

OPERATING CONDITIONS	
MEDIA	Water and water-oil mixture
TEMPERATURE	-30°C +80°C
PRESSURE	≤250 Bar
SPEED	≤2.0 m/sec

Note: The above data are maximum values and cannot be used at the same time.

SURFACE ROUGHNESS		Ra	Rmax
Sliding Surface	Ød	≤0.3 µm	≤4 µm
Groove Base	ØD	≤1.5 µm	≤10 µm

Note: It is recommended to have 50% to 90% of the working surface material contact area value.

INSTALLATION

K150 chevron ring is used in open housing. It is very important that the assembly tools must be of soft material and have no sharp edges. Before installation the sealing element must be oiled with system oil.

NOTES

Thanks to the specially formulated reinforced cotton fabric with nitrile rubber, service life is much longer than the normal cotton fabric seals.

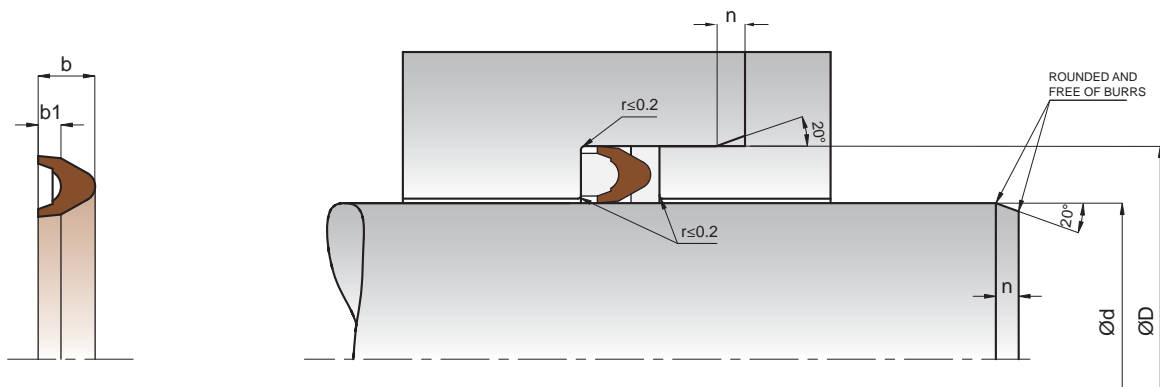
K150 CHEVRON RING

KASTAŞ NO	D (H9)	d (f7)	b	b1	n
K150-025	25	15	5	3	6
K150-026	26	18	5	3	6
K150-028	28	15	6.5	4	7
K150-028/1	28	18	5.5	3.5	6
K150-030	30	15	7.5	4.5	8
K150-030/1	30	16	7	4	8
K150-030/2	30	18	6	3.5	7
K150-030/3	30	20	5.5	3.3	6
K150-032	32	18	7.1	4.6	8
K150-032/1	32	20	6.7	4.5	7
K150-035	35	20	7.5	4.5	8
K150-035/1	35	22	7	4.5	7
K150-035/2	35	24	6	4	7
K150-035/3	35	25	5.5	3.3	6
K150-038	38	22	8.5	3.5	8
K150-038/1	38	25	7	4.6	7
K150-038/2	38	28	6.1	4.1	6
K150-045	45	30	7.5	4.5	8
K150-048	48	36	6	3.5	7
K150-048/1	48	38	6	3.5	6
K150-056	56	36	10	6	9
K150-060	60	45	7.5	4.5	8
K150-060/1	60	50	5.5	3.5	6
K150-065	65	50	7.5	4.5	8
K150-065/1	65	55	5.5	3.5	6
K150-070	70	55	7.5	4.5	8

Please contact our customer service for the dimensions out of our stock list.



K151 is a three piece single acting chevron seal which consists of one thermoplastic header ring, one specially formulated reinforced cotton fabric with nitrile rubber sealing element and one PTFE back-up ring.

PRODUCT ADVANTAGES

- Capable of standing pressure changes
- Long service life
- Works in water and water-oil mixture media
- Easy installation

APPLICATION

High pressure cleaning equipment.

MATERIAL	CODE
COTTON FABRIC NBR	NB8503
POM	PM9901
PTFE	PT6002

OPERATING CONDITION	
MEDIA	Mineral oils, water and water-oil mixture
TEMPERATURE	-30°C +80°C
PRESSURE	≤250 Bar
SPEED	≤2.0 m/sec

Note: The above data are maximum values and cannot be used at the same time.

SURFACE ROUGHNESS		Ra	Rmax
Sliding Surface	Ød	≤0.3 µm	≤4 µm
Groove Base	ØD	≤1.5 µm	≤10 µm
Groove Flanks	B	≤3 µm	≤16 µm

Note: It is recommended to have 50% to 90% of the working surface material contact area value.

INSTALLATION

K151 chevron seal is used in open housing. It is very important that the assembly tools must be of soft material and have no sharp edges. Before installation the sealing element must be oiled with system oil.

NOTES

Thanks to the specially formulated reinforced cotton fabric with nitrile rubber service life is much longer than the normal cotton fabric seals.



K152 is a single acting low pressure chevron seal produced from special formulated reinforced cotton fabric with nitrile rubber sealing element.

K153 is a two piece single acting low pressure chevron seal which consists of one specially formulated reinforced cotton fabric with nitrile rubber sealing element and one thermoplastic header ring.

PRODUCT ADVANTAGES

- Capable of standing pressure changes
- Long service life
- Works in water and water-oil mixture media
- Easy installation

APPLICATION

On the low pressure side of high pressure cleaning equipment.

MATERIAL	CODE
COTTON FABRIC NBR	NB8503
POM	PM9901

OPERATING CONDITIONS	
MEDIA	Mineral oils, water and water-oil mixture
TEMPERATURE	-30°C +80°C
PRESSURE	≤80 Bar
SPEED	≤2.0 m/sec

Note: The above data are maximum values and cannot be used at the same time.

SURFACE ROUGHNESS		Ra	Rmax
Sliding Surface	∅d	≤0.3 μm	≤4 μm
Groove Base	∅D	≤1.5 μm	≤10 μm
Groove Flanks	B	≤3.0 μm	≤16 μm

Note: It is recommended to have 50% to 90% of the working surface material contact area value.

INSTALLATION

K152 and K153 chevron seals are used in open housing. It is very important that the assembly tools must be of soft material and have no sharp edges. Before installation the sealing element must be oiled with system oil.

NOTES

Thanks to the specially formulated reinforced cotton fabric with nitrile rubber service life is much longer than the normal cotton fabric seals.



K702 is a two piece double-acting sealing set which consists of one special mixture PTFE profile ring and an O-ring as energizing element.

PRODUCT ADVANTAGES

- Can be used at high pressures and low peripheral speeds
- Low friction, free of stick-slip
- Simple groove design and low axial housing heights
- Long service life
- High sliding speed
- Wide range of temperature and chemicals depending on the o-ring material
- Minimum static and dynamic friction coefficient for a minimum energy loss and operating temperature

APPLICATION

Mobile hydraulics, grippers and rotary joints.

MATERIAL	CODE	
NBR	70 SHORE A	NB7001
PTFE		PT6003

OPERATING CONDITIONS			
MEDIA	Mineral oils (DIN 51524)	HFA and HFB	HFC
TEMPERATURE	-30°C +105°C	+5°C +60°C	-30°C +60°C
PRESSURE	≤300 Bar	≤300 Bar	≤300 Bar
PERIPHERAL SPEED	≤5.0 m/sec	≤5.0 m/sec	≤5.0 m/sec

Note: The above data are maximum values and cannot be used at the same time.

SURFACE ROUGHNESS		Ra	Rmax
Sliding Surface	Ød	≤0.2 µm	≤2.0 µm
Groove Base	ØD	≤1.6 µm	≤6.3 µm
Groove Flanks	B	≤3.2 µm	≤16 µm

Note: It is recommended to have 50% to 90% of the working surface material contact area value.

INSTALLATION

We recommend using special assembly tool (See section; Hydraulic Sealing Elements General Installation Information). It is very important that the assembly tools must be of soft material and have no sharp edges. Before installation the sealing element must be oiled with system oil.

NOTES

For special applications that require high temperatures or resistance to chemicals, rod seal can be manufactured with special mixture PTFE and FKM. The permissible sealing gap values of K702 rod seal for rotating application is given in the below table.

PERMISSIBLE SEALING GAP			
B (mm)	Smax (mm)		
	100 bar	200 bar	300 bar
2.2	0.15	0.10	0.075
3.2	0.20	0.15	0.10
4.2	0.20	0.15	0.10
6.3	0.30	0.20	0.15
8.1	0.30	0.20	0.15

Note: The largest sealing gap value occurring on the non-pressurized side of the seal is vital for the function of the seal and in this respect it is quite important to use the S value lower than the above indicated numbers.

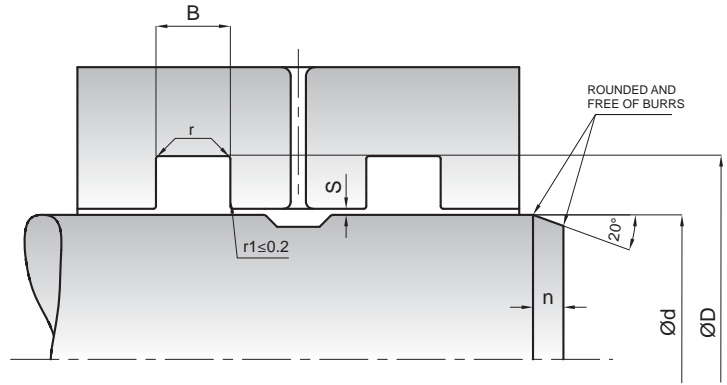
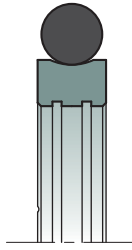

KASTAŞ NO	d (f8)	D (H9)	B (-0/+0.2)	r	n	O-Ring
K702-012	12	16.9	2.2	0.4	2.0	14.00x1.78
K702-015	15	19.9	2.2	0.4	2.0	17.17x1.78
K702-020	20	27.5	3.2	0.6	2.5	21.89x2.62
K702-020/1	20	24.9	2.2	0.4	2.0	21.95x1.78
K702-025	25	32.5	3.2	0.6	2.5	28.25x2.62
K702-025/1	25.4	32.9	3.2	0.6	2.5	28.25x2.62
K702-030	30	37.5	3.2	0.6	2.5	33.00x2.62
K702-035	35	42.5	3.2	0.6	2.5	37.77x2.62
K702-040	40	51	4.2	0.8	3.5	44.04x3.53
K702-045	45	56	4.2	0.8	3.5	50.39x3.53
K702-050	50	61	4.2	0.8	3.5	53.57x3.53
K702-055	55	66	4.2	0.8	3.5	59.92x3.53
K702-060	60	71	4.2	0.8	3.5	65.10x3.53
K702-060/1	60	75.5	6.3	1.2	5	66.04x5.33
K702-065	65	76	4.2	0.8	3.5	69.44x3.53
K702-070	70	81	4.2	0.8	3.5	75.79x3.53
K702-075	75	86	4.2	0.8	3.5	78.97x3.53
K702-080	80	91	4.2	0.8	3.5	85.32x3.53
K702-085	85	96	4.2	0.8	3.5	88.49x3.53
K702-090	90	101	4.2	0.8	3.5	94.84x3.53
K702-095	95	106	4.2	0.8	3.5	101.19x3.53
K702-100	100	111	4.2	0.8	3.5	104.37x3.53
K702-105	105	116	4.2	0.8	3.5	110.72x3.53
K702-110	110	121	4.2	0.8	3.5	113.90x3.53
K702-115	115	126	4.2	0.8	3.5	120.24x3.53
K702-120	120	131	4.2	0.8	3.5	123.40x3.53
K702-125	125	136	4.2	0.8	3.5	129.77x3.53
K702-130	130	141	4.2	0.8	3.5	136.12x3.53
K702-140	140	151	4.2	0.8	3.5	145.64x3.53
K702-145	145	156	4.2	0.8	3.5	148.82x3.53
K702-150/1	150	165.5	6.3	1.2	5	158.12x5.33
K702-160	160	171	4.2	0.8	3.5	164.70x3.53
K702-170	170	181	4.2	0.8	3.5	171.05x3.53
K702-180	180	191	4.2	0.8	3.5	183.75x3.53
K702-200	200	215.5	6.3	1.2	5	208.92x5.33
K702-210	210	225.5	6.3	1.2	5	215.27x5.33
K702-220	220	235.5	6.3	1.2	5	227.97x5.33
K702-240	240	255.5	6.3	1.2	5	247.02x5.33
K702-250	250	265.5	6.3	1.2	5	253.57x5.33
K702-300	300	321	8.1	1.6	6.5	304.17x6.99



K752 is a two piece double-acting sealing set which consists of one special mixture PTFE profile ring and an o-ring as energizing element.

PRODUCT ADVANTAGES

- Can be used at high pressures and low peripheral speeds
- Low friction, free of stick-slip
- Simple groove design and low axial housing heights
- Long service life
- High sliding speed
- Wide range of temperature and chemicals depending on the o-ring material
- Minimum static and dynamic friction coefficient for a minimum energy loss and operating temperature

APPLICATION

Mobile hydraulics, grippers and rotary joints.

MATERIAL	CODE	
NBR	70 SHORE A	NB7001
PTFE		PT6003

OPERATING CONDITIONS			
MEDIA	Mineral oils (DIN 51524)	HFA and HFB	HFC
TEMPERATURE	-30°C +105°C	+5°C +60°C	-30°C +60°C
PRESSURE	≤300 Bar	≤300 Bar	≤300 Bar
PERIPHERAL SPEED	≤5.0 m/sec	≤5.0 m/sec	≤5.0 m/sec

Note: The above data are maximum values and cannot be used at the same time.

SURFACE ROUGHNESS		Ra	Rmax
Sliding Surface	∅D	≤0.2 μm	≤2.0 μm
Groove Base	∅d	≤1.6 μm	≤6.3 μm
Groove Flanks	B	≤3.2 μm	≤16 μm

Note: It is recommended to have 50% to 90% of the working surface material contact area value.

INSTALLATION

We recommend using special assembly tool (See section; Hydraulic Sealing Elements General Installation Information). It is very important that the assembly tools must be of soft material and have no sharp edges. Before installation the sealing element must be oiled with system oil.

NOTES

For special applications that require high temperatures or resistance to chemicals, piston seal can be manufactured with special mixture PTFE and FKM. The permissible sealing gap values of K752 piston seal for rotating application is given in the below table.

PERMISSIBLE SEALING GAP			
B (mm)	Smax (mm)		
	100 bar	200 bar	300 bar
2.2	0.15	0.10	0.075
3.2	0.20	0.15	0.10
4.2	0.20	0.15	0.10
6.3	0.30	0.20	0.15
8.1	0.30	0.20	0.15

Note: The largest sealing gap value occurring on the non-pressurized side of the seal is vital for the function of the seal and in this respect it is quite important to use the S value lower than the above indicated numbers.

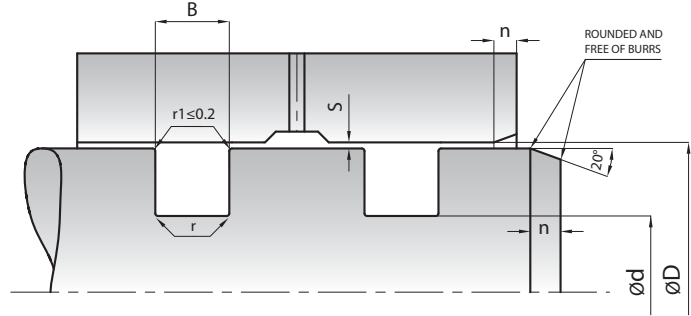
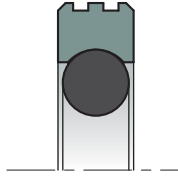

KASTAŞ NO	D (H8)	Ød (h9)	B (-0/+0.2)	r	n	O-Ring
K752-015	15	10.1	2.2	0.4	2	9.25x1.78
K752-020	20	15.1	2.2	0.4	2	14.00x1.78
K752-025	25	20.1	2.2	0.4	2	18.77x1.78
K752-030	30	25.1	2.2	0.4	2	23.53x1.78
K752-032	32	27.1	2.2	0.4	2	26.70x1.78
K752-035	35	30.1	2.2	0.4	2	28.30x1.78
K752-040	40	32.5	3.2	0.6	2.5	31.42x2.62
K752-040/1	40	29	4.2	0.8	3.5	28.17x3.53
K752-045	45	37.5	3.2	0.6	2.5	36.17x2.62
K752-050	50	42.5	3.2	0.6	2.5	40.95x2.62
K752-052	52	44.5	3.2	0.6	2.5	42.52x2.62
K752-055	55	47.5	3.2	0.6	2.5	45.69x2.62
K752-060	60	52.5	3.2	0.6	2.5	50.47x2.62
K752-063	63	55.5	3.2	0.6	2.5	53.65x2.62
K752-065	65	57.5	3.2	0.6	2.5	56.82x2.62
K752-070	70	62.5	3.2	0.6	2.5	61.60x2.62
K752-075	75	67.5	3.2	0.6	2.5	66.35x2.62
K752-080	80	69	4.2	0.8	3.5	66.68x3.53
K752-080/1	80	64.5	6.3	1.2	5	62.87x5.33
K752-085	85	74	4.2	0.8	3.5	72.62x3.53
K752-090	90	79	4.2	0.8	3.5	78.97x3.53
K752-095	95	84	4.2	0.8	3.5	82.14x3.53
K752-100	100	89	4.2	0.8	3.5	88.50x3.53
K752-105	105	94	4.2	0.8	3.5	91.67x3.53
K752-110	110	99	4.2	0.8	3.5	98.02x3.53
K752-115	115	104	4.2	0.8	3.5	101.20x3.53
K752-120	120	109	4.2	0.8	3.5	107.54x3.53
K752-125	125	114	4.2	0.8	3.5	113.90x3.53
K752-130	130	119	4.2	0.8	3.5	117.07x3.53
K752-135	135	119.5	6.3	1.2	5	116.84x5.33
K752-135/1	135	124	4.2	0.8	3.5	120.25x3.53
K752-140	140	124.5	6.3	1.2	5	123.19x5.33
K752-145	145	134	4.2	0.8	3.5	129.77x3.53
K752-150	150	134.5	6.3	1.2	5	132.72x5.33
K752-160	160	144.5	6.3	1.2	5	142.24x5.33
K752-170	170	154.5	6.3	1.2	5	151.77x5.33
K752-180	180	164.5	6.3	1.2	5	164.47x5.33
K752-190	190	174.5	6.3	1.2	5	170.82x5.33
K752-200	200	184.5	6.3	1.2	5	183.52x5.33
K752-210	210	194.5	6.3	1.2	5	196.22x5.33
K752-220	220	204.5	6.3	1.2	5	202.57x5.33
K752-230	230	214.5	6.3	1.2	5	208.92x5.33
K752-240	240	224.5	6.3	1.2	5	221.62x5.33
K752-250	250	234.5	6.3	1.2	5	227.97x5.33
K752-260	260	244.5	6.3	1.2	5	240.67x5.33
K752-300	300	284.5	6.3	1.2	5	278.77x5.33



Blank lined writing area consisting of 25 horizontal light gray lines.



PNEUMATIC SEALING ELEMENTS

Working Principle of Sealing Elements

Sealing elements are designed for the pressurized gas not to pass to the un-pressurized side in pneumatic systems. Pneumatic cylinders are widely used in mechanical applications that require low forces with high reciprocating sliding speeds. Sealing elements are one of the most important parts of these cylinders.

The sealing elements are being installed into the respective groove with a preload. Figure 22 shows the sealing element, preloaded after the assembly of the seal and the free space needed in the housing. The sealing element is able to work in low pressures due to this preload. Figure 23 shows the pressurized air filling into the groove and sealing element is expanded with this pressure.

Sealing elements are produced from such materials that can change their form when force is applied (Figure 23) and can return to the original form when this force disappears (Figure 22). In this respect sealing elements are produced from elastomers, thermoplastics or thermoplastic elastomers.

Sealing elements do have more than one duty in pneumatic cylinder due to the limited space and the cost. That's why most of the rod seals work both as a wiper and a rod seal. In piston sealing elements, the designs are used to avoid the necessity of having a piston itself.

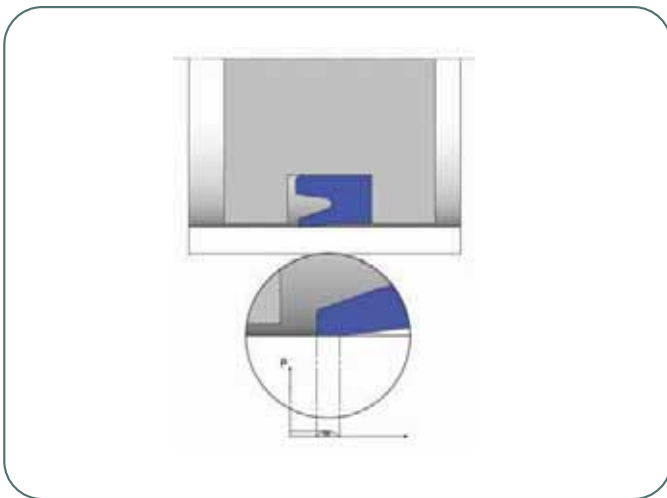

Figure 22
Pressure distribution on static condition

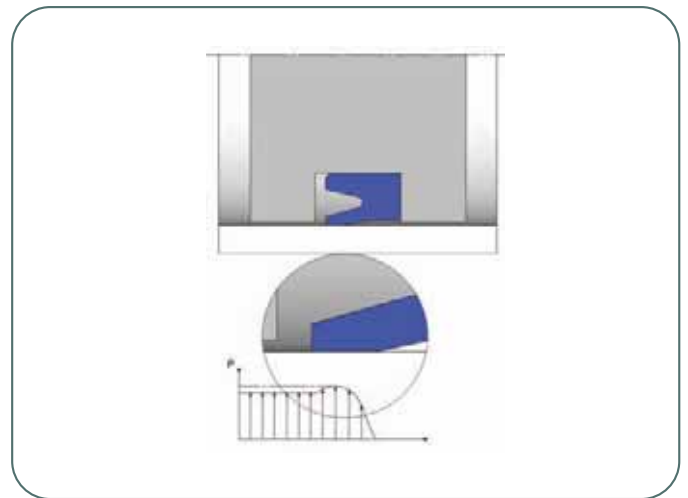

Figure 23
Pressure distribution on system pressure

CHOOSING SEALING ELEMENTS

System pressure, sliding speed, temperature, media, surface roughness and system tolerances are the important parameters when choosing the type of the pneumatic sealing element.

PRESSURE

The pressure does not go beyond 16 bar (special applications only) in pneumatic systems. That is why the pressure source (air compressors, etc) settings are between 3 to 8 bar. The expectation from the pneumatic sealing element is to function properly with no interruption in low pressures.

SPEED

Pneumatic systems increasingly being used in automation processes and requires high sliding speed. The speeds (0.5 m/sec and higher) are generally higher than the hydraulic applications and these are named medium speeds in pneumatics. The negative effects of the friction forces cause by high sliding speed should be taken into consideration when choosing the material and profile to have the optimum sealing in the system.

TEMPERATURE

Operating temperature and local temperature increase due to the friction forces should be taken into consideration when choosing the sealing elements in pneumatic systems. For high temperature applications sealing elements can be used from PTFE and FKM.

AIR

Generally, the compressed air contains dust, dirt and moisture if no prior operation is applied on it. Life span of the sealing element shortens under this operating condition. That is why filters should be used in order to purify the air from the compressor oil and to clean the air. Maximum cleanliness is essential before greasing and commissioning; the system must be completely free from machining residue, old lubricants and any other contaminations. Prepared compressed air should be used as dried or conditioned with special lubricants. Special assembly grease should be used for the sealing elements that will be working in non oiled systems in order to have optimum friction forces.

SURFACE ROUGHNESS

The maximum surface roughness value, R_{max} , is the most important factor that affects the life span of the sealing elements in pneumatic systems. Surface roughness values should be according to the catalogue information provided in the each product group.

R_z value that we indicate in our catalogue is the average of the 5 consecutive maximum roughness values in specific length of surface, R_{max} is the maximum of these values and R_p is the height of the surface roughness (Figure 24).

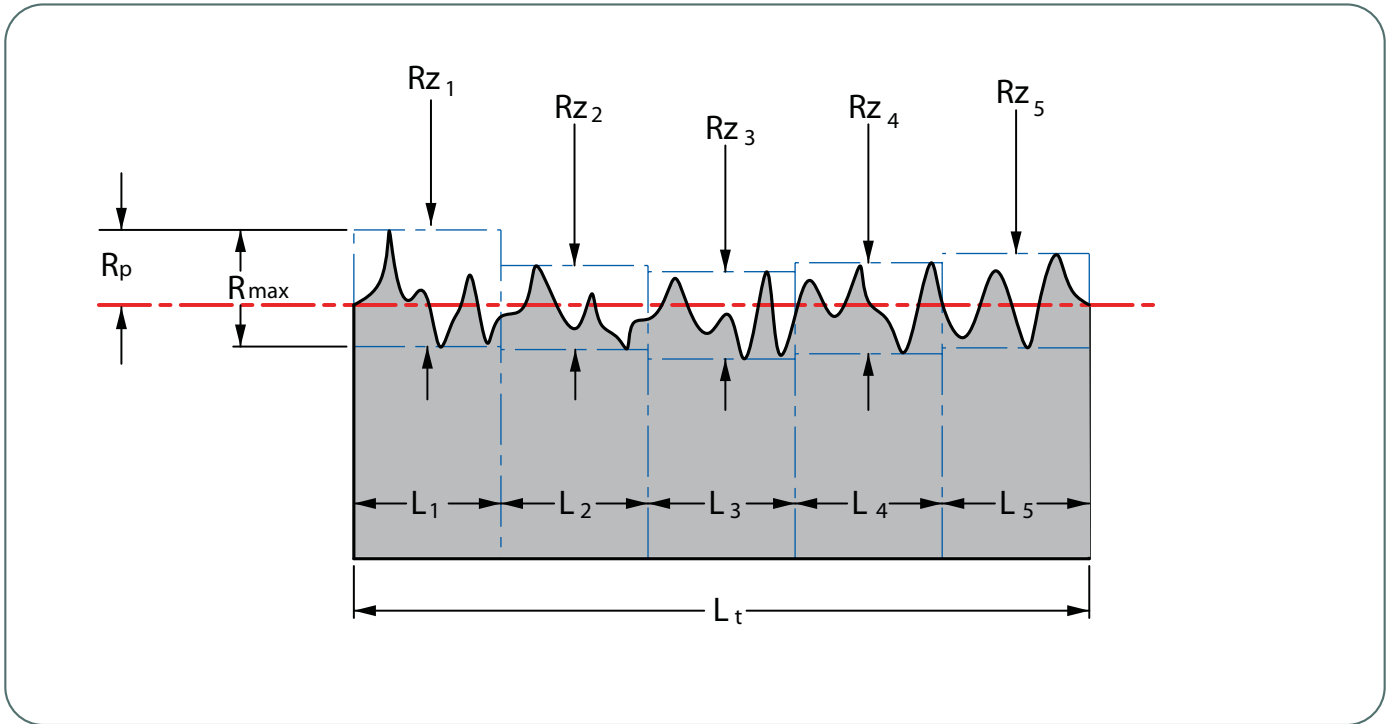

Figure 24
Rz surface roughness value and calculation of R_{max}

We recommend R_{max} value not to be higher than the value given in our catalogue and R_p/R_z ratio to be less than 0.5. Surface contact area R_{mr} ratio is also an important factor in the surface roughness.

$$R_z = \frac{R_{z_1} + R_{z_2} + R_{z_3} + R_{z_4} + R_{z_5}}{5}$$

SYSTEM TOLERANCES AND DESIGNS

System tolerances are important factors on the life span of the sealing elements. Inappropriate dimensions, tolerances and not centered pneumatic cylinders make the sealing elements wear out in short period of time and the system does not give the required performance. All the dimensions and tolerances are indicated on the product pages in our catalogue. Table 3 shows the general tolerances used in the pneumatic systems.

The cylinder bore in pneumatic cylinders are manufactured from steel, soft metals such as aluminium and special engineering plastics. Sliding surfaces should have the following mentioned operations (honed, grinded, etc) in order to obtain the required surface roughness values. Rods are produced from chrome plated steel (55 HRC) and should be grinded, polished. Other cylinder components are produced from steel, aluminium and special engineering plastics.

TOLERANCES IN PNEUMATIC CYLINDERS

NOMINAL DIMENSION (mm)		HOLE TOLERANCES (µm)						ROD TOLERANCES (µm)								
		H8	H9	H10	H11	H12	e9	f7	f8	f9	h8	h9	h10	h11		
>	<=															
	3	+14	+25	+40	+60	+100	-14	-6	-6	-6	0	0	0	0	0	0
3	6	-0	-0	-0	-0	-0	-39	-16	-20	-20	-14	-25	-40	-60	-60	-60
	6	+18	+30	+48	+75	+120	-20	-10	-10	-10	0	0	0	0	0	0
6	10	-0	-0	-0	-0	-0	-50	-22	-28	-28	-18	-30	-48	-75	-75	-75
	10	+22	+36	+58	+90	+150	-25	-13	-13	-13	0	0	0	0	0	0
10	18	-0	-0	-0	-0	-0	-61	-28	-35	-35	-22	-36	-58	-90	-90	-90
	18	+27	+43	+70	+110	+180	-32	-16	-16	-16	0	0	0	0	0	0
18	30	-0	-0	-0	-0	-0	-75	-34	-43	-43	-27	-43	-70	-110	-110	-110
	30	+33	+52	+84	+130	+210	-40	-20	-20	-20	0	0	0	0	0	0
30	50	-0	-0	-0	-0	-0	-92	-41	-53	-53	-33	-52	-84	-130	-130	-130
	50	+39	+62	+100	+160	+250	-50	-25	-25	-25	0	0	0	0	0	0
50	80	-0	-0	-0	-0	-0	-112	-50	-64	-64	-39	-62	-100	-160	-160	-160
	80	+46	+74	+120	+190	+300	-60	-30	-30	-30	0	0	0	0	0	0
80	120	-0	-0	-0	-0	-0	-134	-60	-76	-76	-46	-74	-120	-190	-190	-190
	120	+54	+87	+140	+220	+350	-72	-36	-36	-36	0	0	0	0	0	0
120	180	-0	-0	-0	-0	-0	-159	-71	-90	-90	-54	-87	-140	-220	-220	-220
	180	+63	+100	+160	+250	+400	-85	-43	-43	-43	0	0	0	0	0	0
180	250	-0	-0	-0	-0	-0	-185	-83	-106	-106	-63	-100	-160	-250	-250	-250
	250	+72	+115	+185	+290	+460	-100	-50	-50	-50	0	0	0	0	0	0
250	315	-0	-0	-0	-0	-0	-215	-96	-122	-122	-72	-115	-185	-290	-290	-290
	315	+81	+130	+210	+320	+520	-110	-56	-56	-56	0	0	0	0	0	0
315	400	-0	-0	-0	-0	-0	-240	-108	-137	-137	-81	-130	-210	-320	-320	-320
	400	+89	+140	+230	+360	+570	-125	-62	-62	-62	0	0	0	0	0	0
400	500	-0	-0	-0	-0	-0	-265	-119	-151	-151	-89	-140	-230	-360	-360	-360
	500	+97	+155	+250	+400	+630	-135	-68	-68	-68	0	0	0	0	0	0
400	500	-0	-0	-0	-0	-0	-290	-131	-165	-165	-97	-155	-250	-400	-400	-400
	500	+97	+155	+250	+400	+630	-135	-68	-68	-68	0	0	0	0	0	0

FRICITION FORCE

Friction force has an important role not only on the life span of the sealing element but also effects proper functioning in low pressures for pneumatic cylinders. Figure 25 shows the relation of the friction forces against sliding speed.

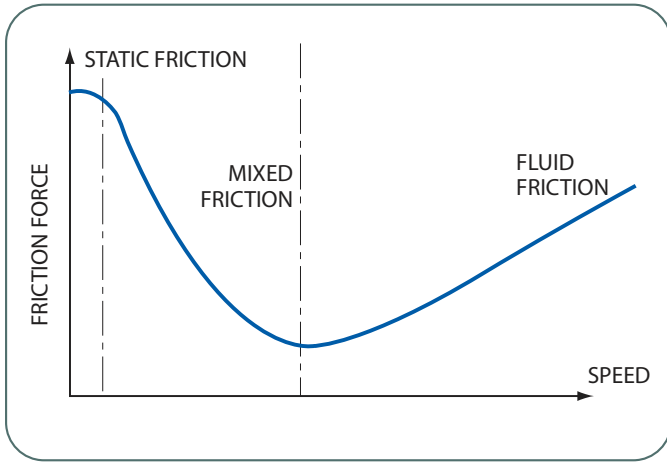

Figure 25
Friction Force vs Sliding Speed

The friction and wear between two bodies sliding over each other can be minimized if two friction surfaces are completely separated by a lubricated layer. Sealing lips of the pneumatic sealing element is much thinner and longer compared to the hydraulic sealing element in order to have optimum oil film thickness and the lowest friction forces.

Suitable sealing element leaves ideal oil film thickness on the contact area; the proper surface roughness value brings the curve downwards and reduces the friction forces (Figure 26).

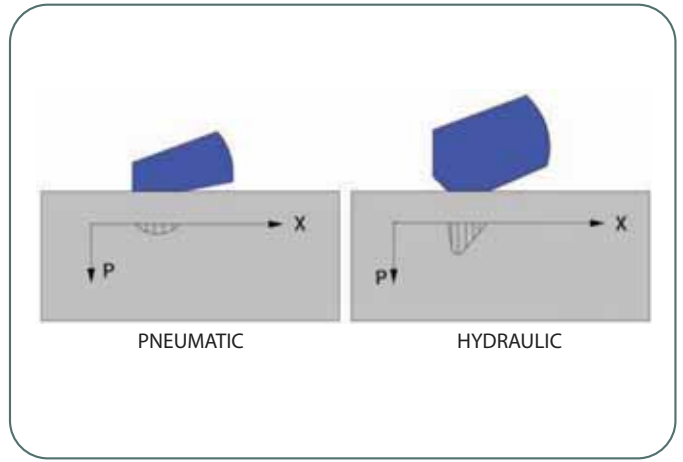

Figure 26
Forces on the lips of the sealing elements

This special geometry helps to have ideal forces on dry working applications generally during the installation process. Friction forces are minimized and the life span of the sealing element is extended.

INSTALLATION

Before installation; we highly recommend to see section; General Installation Information of Technical Catalogue. The complete system must be cleaned of machining chips, dirt and other particles. Sealing elements should not be pulled over sharp edges and should be oiled with system oil prior to the installation.

Cylinder bores and rods should be chamfered to prevent damage to the sealing element during the installation. All edges around the seal housing should be de-burred and rounded. Sealing element, rod and cylinder bore should be oiled before installation. Below table shows the required chamfer values (Figure 27).

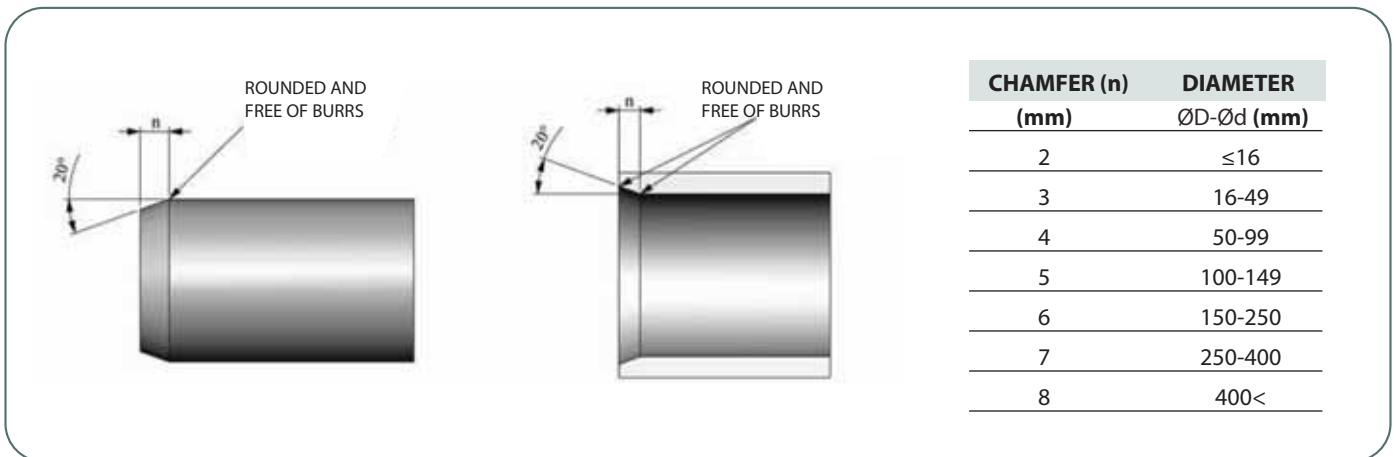

Figure 27
Chamfer values

Special assembly tools are recommended for sealing elements that will be installed into closed grooves. These tools can shorten the installation time and prevent damaging of the sealing elements. Some installation tools for rod and piston seals can be seen below.

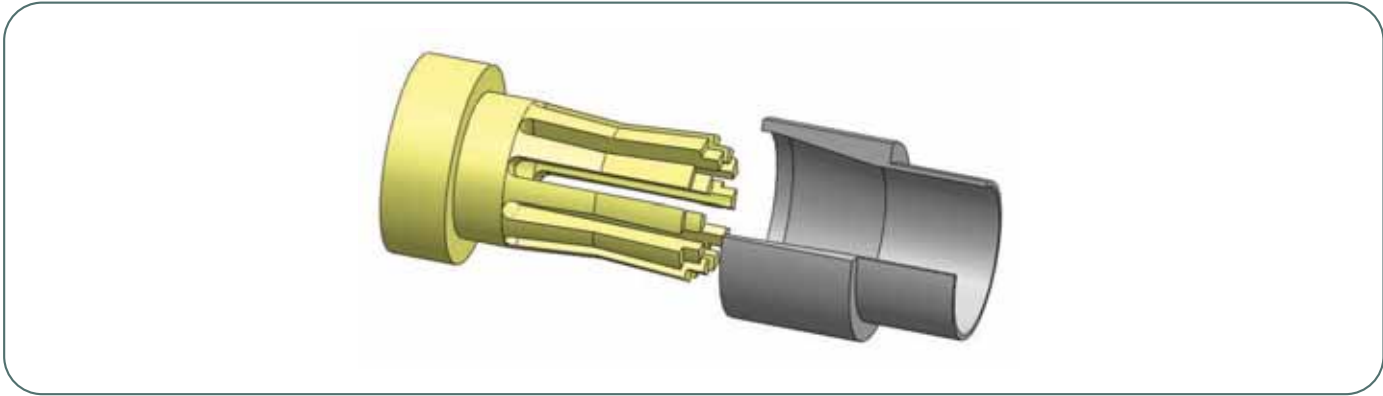

Figure 28
Assembly tool for gland cap

After the installation of the rod seals, in order not to have damage on the sealing elements while pushing the rod through the gland cap special assembly tool shown in Figure 29 should be used.

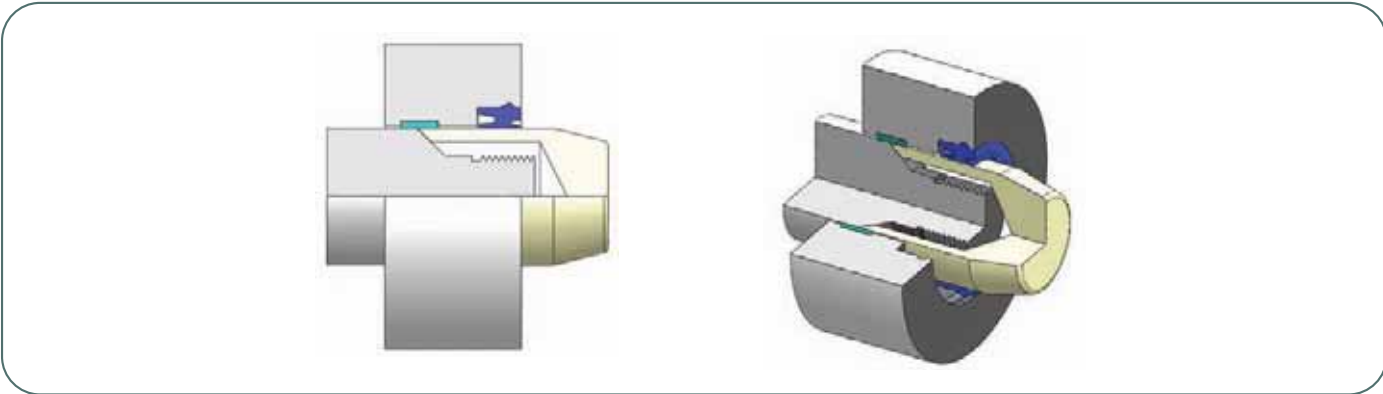

Figure 29
Assembly tool prior to installation of the rod

After the installation of the piston seals, in order not to have damage on the sealing elements while pushing the piston into the cylinder bore special assembly tool shown in Figure 30 should be used.

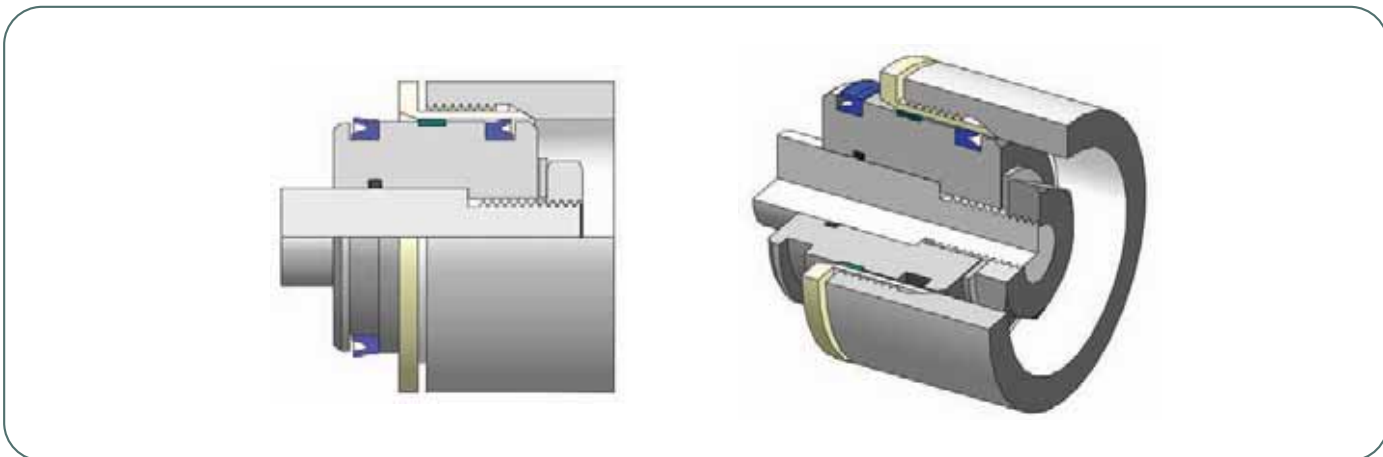
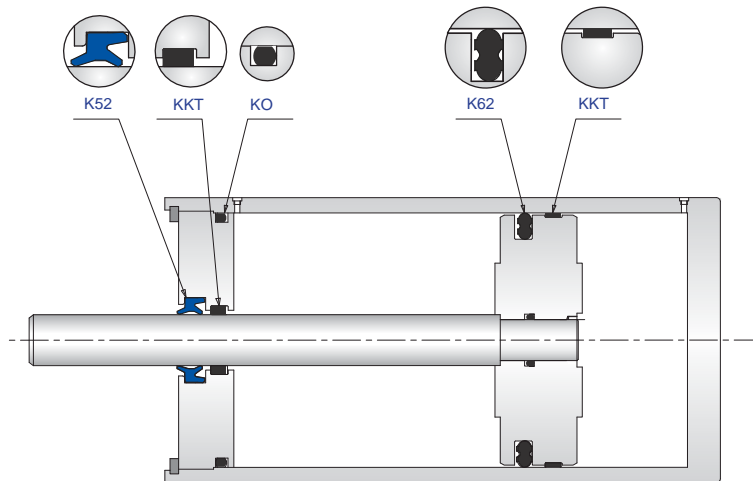
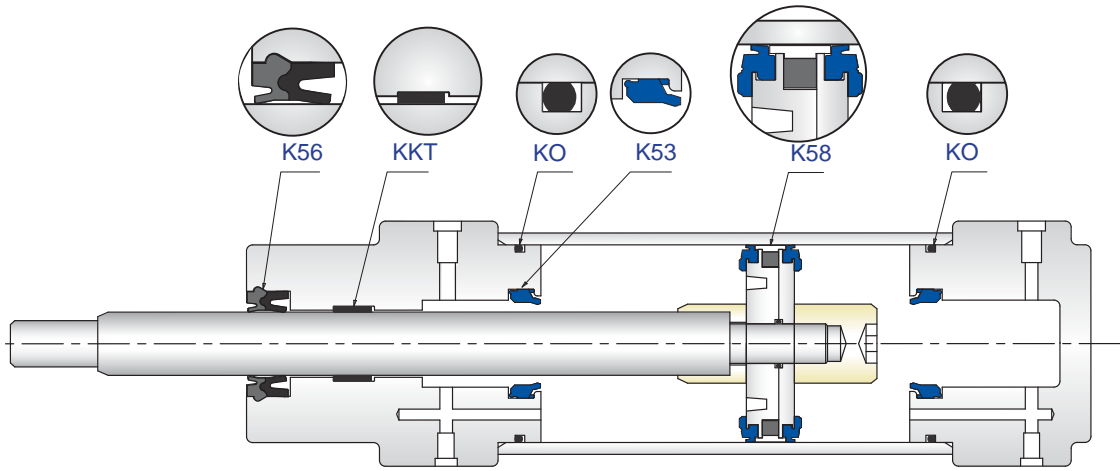
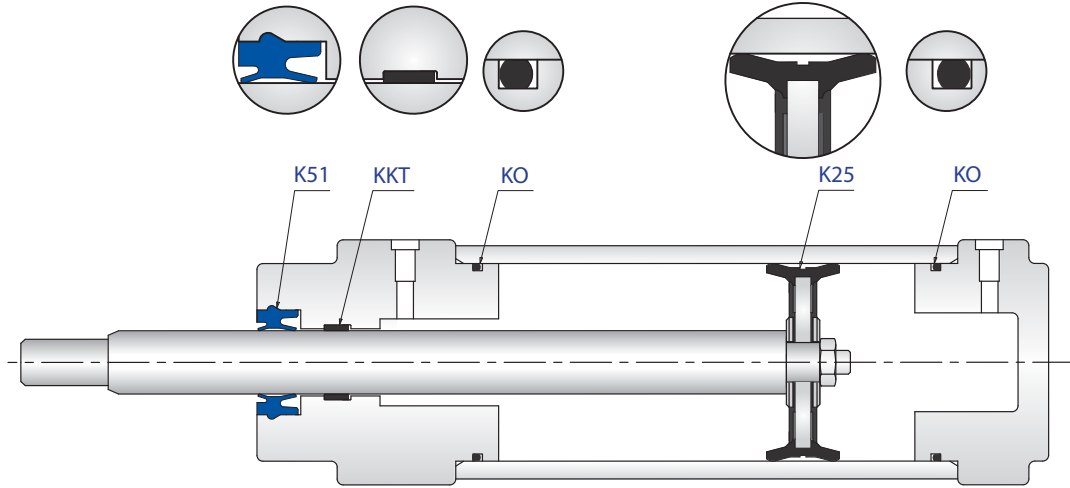

Figure 30
Example of installation tool for piston

SAMPLE DESIGNS





21 horizontal light gray lines for writing.



PNEUMATIC ROD SEALING ELEMENTS



21 horizontal light gray lines for writing.



K30 is a single acting wiper seal combination which consists of a metal vulcanized with elastomeric nitrile rubber using special production methods.

PRODUCT ADVANTAGES

- Superior wiping effect
- Superior sealing effect
- Wide range of dimensions
- Able to work in hard conditions
- Good adjustment to temperature changes thanks to the metal ring

APPLICATION

Pneumatic cylinders.

MATERIAL		CODE
NBR	70 SHORE A	NB7001
STEEL	ST37	FE9901

OPERATING CONDITIONS	
MEDIA	Prepared, dried and de-oiled compressed air
TEMPERATURE	-30°C +105°C
PRESSURE	≤16 Bar
SPEED	≤1.0 m/sec

Note: The above data are maximum values and cannot be used at the same time.

SURFACE ROUGHNESS

		Rmax
Sliding Surface	Ød	≤4 µm
Groove Base	ØD2	≤10 µm
Groove Flanks	S1	≤15 µm

INSTALLATION

K30 wiper/seal is fitted into the housing by means of a circlip recess. The sealing part is pushed in and fixed by the circlip. It is very important that the assembly tools must be of soft material and have no sharp edges. Before installation the sealing element must be oiled with system oil.

NOTES

For special applications that require high temperatures, K30 can be produced in FKM.



K51 is a single acting pneumatic rod seal specially designed not to require additional element for axial fitting within the housing.

PRODUCT ADVANTAGES

- Superior sealing effect
- Minimal space requirement
- Easy installation to open grooves
- Wide range of dimensions
- Economical sealing solution
- High wear resistant

APPLICATION

Pneumatic cylinders.

MATERIAL	CODE	
PU	92 SHORE A	PU9201

OPERATING CONDITIONS	
MEDIA	Prepared, dried and de-oiled compressed air
TEMPERATURE	-30°C +80°C
PRESSURE	≤16 Bar
SPEED	≤1.0 m/sec

Note: The above data are maximum values and cannot be used at the same time.

SURFACE ROUGHNESS

		Rmax
Sliding Surface	Ød	≤4 µm
Groove Base	ØD	≤10 µm
Groove Flanks		≤15 µm

INSTALLATION

It can be assembled into closed groove with tight hand force. K51 does not need additional element such as circlip for axial fitting within the housing. We recommend using special assembly tool. It is very important that the assembly tools must be of soft material and have no sharp edges. Before installation the sealing element must be oiled with system oil.



K52 is a single acting pneumatic wiper ensuring that foreign particles do not penetrate into the hydraulic cylinders. The lip is designed in a particular way that it functions as a rod seal and wiper.

PRODUCT ADVANTAGES

- Superior sealing effect
- Superior wiping effect
- Low static and dynamic friction
- Minimal space requirement
- High wear resistant

APPLICATION

Compact and special small cylinders.

MATERIAL		CODE
NBR	90 SHORE A	NB9001
PU	92 SHORE A	PU9201

OPERATING CONDITIONS	
NBR	
MEDIA	Prepared, dried and de-oiled compressed air
TEMPERATURE	-30°C +105°C
PRESSURE	≤12 Bar
SPEED	≤1.0 m/sec

PU	
MEDIA	Prepared, dried and de-oiled compressed air
TEMPERATURE	-30°C +80°C
PRESSURE	≤16 Bar
SPEED	≤1.0 m/sn

Note: The above data are maximum values and cannot be used at the same time.

SURFACE ROUGHNESS

SURFACE ROUGHNESS		Rmax
Sliding Surface	Ød	≤4 µm
Groove Base	ØD	≤10 µm
Groove Flanks	B	≤15 µm

INSTALLATION

It can be assembled into closed groove by hand. K52 does not need additional element such as circlip for axial fitting within the housing. We recommend using special assembly tool. It is very important that the assembly tools must be of soft material and have no sharp edges. Before installation the sealing element must be oiled with system oil.

NOTES

For special applications that require high temperatures, K52 can be produced in FKM.

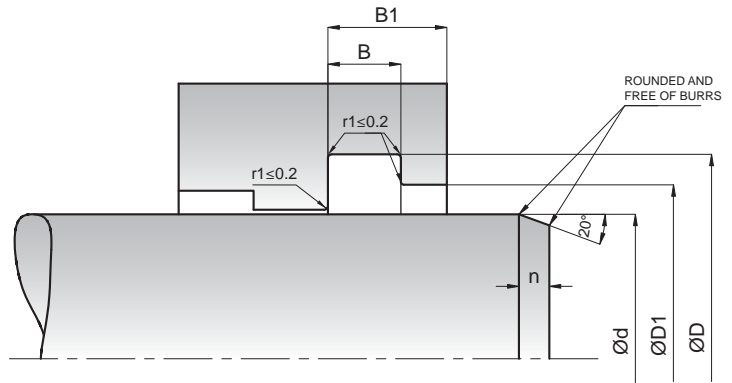
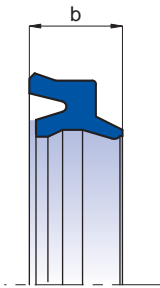

KASTAŞ NO	NBR	PU	d (f9)	D (H11)	D1 (-0/+0.2)	B (-0/+0.2)	B1	b
K52-004	NBR	PU	4	8.2	6.5	3	4.8	4
K52-006	NBR	PU	6	11.2	9	4	5.2	5
K52-008	NBR	PU	8	14.2	12	4	5.2	5
K52-010	NBR	PU	10	16.2	14	4.5	6	5.5
K52-012	NBR	PU	12	16.5	13.7	3.6	4.8	4
K52-016	NBR	PU	16	20.5	17.7	3.6	4.8	4
K52-020		PU	20	25	21.9	4	5.2	4.6
K52-025		PU	25	30	26.9	4	5.2	4.6
K52-030		PU	30	35.5	31.9	4.5	6	4.8

Please contact our customer service for the dimensions out of our stock list.



K56 is a two piece single acting pneumatic rod seal which consists of one nitrile rubber sealing element and one polyester elastomer scrapper profile ring.

PRODUCT ADVANTAGES

- Good scrapping with special geometry and material
- High resistance to operating temperature changes
- Superior sealing effect
- Low static and dynamic friction values

APPLICATION

Pneumatic cylinders.

MATERIAL		CODE
NBR	80 SHORE A	NB8001
TPE	55 SHORE D	TP5501

OPERATING CONDITIONS	
MEDIA	Prepared, dried and de-oiled compressed air
TEMPERATURE	-30°C +105°C
PRESSURE	≤16 Bar
SPEED	≤1.0 m/sec

Note: The above data are maximum values and cannot be used at the same time.

SURFACE ROUGHNESS

SURFACE ROUGHNESS		Rmax
Sliding Surface	Ød	≤4 µm
Groove Base	ØD	≤10 µm
Groove Flanks	B1	≤15 µm

INSTALLATION

It can be assembled into closed groove with tight hand force. K56 does not need additional element such as circlip for axial fitting within the housing. We recommend using special assembly tool. It is very important that the assembly tools must be of soft material and have no sharp edges. Before installation the rod seal must be oiled with system oil.

NOTES

For special applications that require high temperatures, K56 can be produced in combination of FKM and PTFE.



K53 is a pneumatic cushioning seal with special design spacer lug and flow passages to cushion at the end of the stroke in pneumatic cylinders.

PRODUCT ADVANTAGES

- Easy installation
- Reliable damping due to the flow passages and automatic centering
- Able to work in hard conditions

APPLICATION

Pneumatic cylinders.

MATERIAL		CODE
NBR	90 SHORE A	NB9001
PU	92 SHORE A	PU9201

OPERATING CONDITIONS	
NBR	
MEDIA	Prepared, dried and de-oiled compressed air
TEMPERATURE	-30°C +105°C
PRESSURE	≤12 Bar
SPEED	≤1.0 m/sec

PU	
MEDIA	Prepared, dried and de-oiled compressed air
TEMPERATURE	-30°C +80°C
PRESSURE	≤16 Bar
SPEED	≤1.0 m/sec

Note: The above data are maximum values and cannot be used at the same time.

SURFACE ROUGHNESS		Rmax
Sliding Surface	Ød	≤4 µm
Groove Base	ØD	≤10 µm
Groove Flanks		≤15 µm

INSTALLATION

It can be installed into closed groove manually. It is very important that the assembly tools must be of soft material and have no sharp edges. Before installation the sealing element must be oiled with system oil.

NOTES

For special applications that require high temperatures, K53 can be produced in FKM.

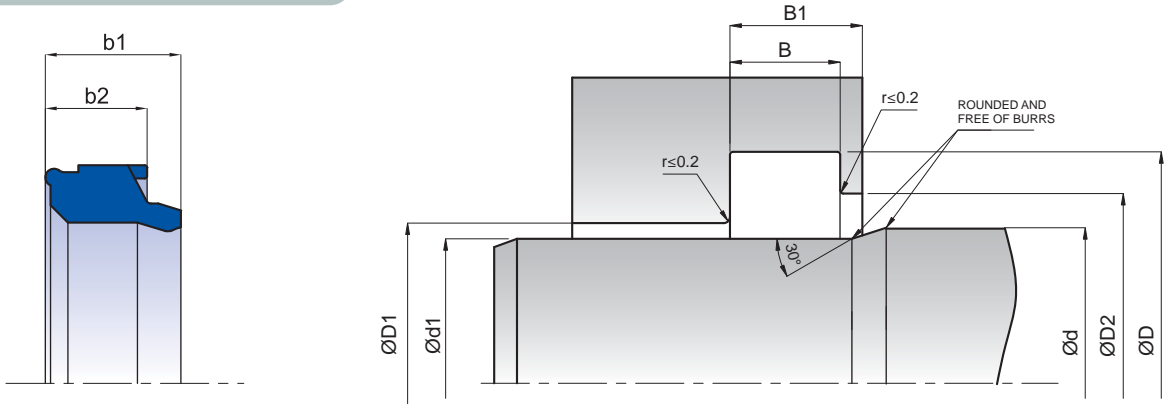

KASTAŞ NO	NBR	PU	d (h10)	D (H11)	D1 max (H11)	D2 (H11)	d1 (f8)	b1	b2	B (±0.1)	B1(±0.2)
K53-008	NBR		8	11.6	8.5	10	4	3.5	2.8	3.3	5.3
K53-009.5	NBR		9.5	15	10	12	5.5	4.6	3.7	4.5	6.5
K53-012	NBR	PU	12	18	13	15.5	8	5	4.1	4.8	6.8
K53-012/1	NBR	PU	12	20	13	17	8	7.8	6.2	7	9
K53-014	NBR	PU	14	22	15	19	10	7.8	6.2	7	9
K53-016	NBR	PU	16	24	17	21	12	7.8	6.2	7	9
K53-016/1	NBR	PU	16	22	17	19.5	12	5.5	4.7	5.2	7.2
K53-020	NBR	PU	20	28	21	24	16	7.8	6.2	7	9
K53-022	NBR		22	30	23	26	18	7.8	6.2	7	9
K53-024	NBR	PU	24	32	25	28	20	7.8	6.2	7	9
K53-025	NBR	PU	25	33	26	29	21	7.8	6.2	7	9
K53-025/1		PU	25	35	26	30	21	7.8	6.2	7	9
K53-030	NBR	PU	30	40	31.5	35	26	7.8	6.2	7	9
K53-032		PU	32	40	33.5	37	28	7.8	6.2	7	9
K53-036	NBR	PU	36	46	37.5	41	32	7.8	6.2	7	9
K53-040	NBR	PU	40	50	41.5	45	36	7.8	6.2	7	9
K53-050		PU	50	67	53	58	46	11	11	12.5	14.5
K53-050/1		PU	50	60	51.5	55	46	7.8	6.2	7	9
K53-057		PU	57	74	60	65	53	11	10	12.5	14.5
K53-070		PU	70	87	73	78	66	11	10	12.5	14.5



22 horizontal lines for text entry, each with a light gray background.



PNEUMATIC PISTON SEALING ELEMENTS



20 horizontal light gray lines for writing, spaced evenly down the page.

KASTAS CODE	PRODUCT NAME	DRAWING	APPLICATION	MATERIAL	CODE	PRESSURE (max) bar	TEMPERATURE (max) °C	SLIDING SPEED (max) - m/sec	PAGE
K25	Pneumatic Piston Seal		Piston	NBR STEEL	NB7501 FE9901	16	-30/+105	1.0	232
K50	Pneumatic Piston Seal		Piston	NBR PU	NB8001 PU8001	12 16	-30/+105 -30/+80	1.0 1.0	234
K54	Pneumatic Piston Seal		Piston	NBR	NB7001	12	-30/+105	1.0	236
K55	Pneumatic Piston Seal		Piston	NBR ALUMINIUM	NB7001 AL9901	12	-30/+105	1.0	238
K57	Pneumatic Piston Seal		Piston	NBR ALUMINIUM	NB7001 AL9901	12	-30/+105	1.0	240
K58	Pneumatic Piston Seal		Piston	PU POM ALUMINIUM MAGNET NBR	PU9201 PM9901 AL9901 MK9901 NB7001	12	-30/+80	1.0	242
K59	Pneumatic Piston Seal		Piston	NBR PU	NB8001 PU8001	12 16	-30/+105 -30/+80	1.0 1.0	244
K62	Pneumatic Piston Seal		Piston	NBR	NB7001	12	-30/+105	1.0	246
K63	Pneumatic Piston Seal		Piston	NBR	NB7001	12	-30/+105	1.0	248

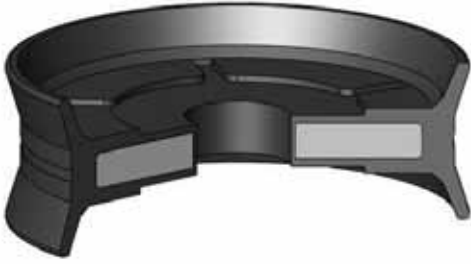

K25 is a double acting complete piston seal which consists of a steel plate vulcanized with elastomeric nitrile rubber using special production methods.

PRODUCT ADVANTAGES

- Ready to fit complete piston
- Wide range of dimensions
- Low friction and smooth running due to sealing lip geometry
- Easily fastened to the piston rod without using additional sealing elements
- Long service life
- Economical sealing solution

APPLICATION

Steel and aluminium pneumatic cylinders.

MATERIAL		CODE
NBR	75 SHORE A	NB7501
STEEL	ST37	FE9901

OPERATING CONDITIONS	
MEDIA	Prepared, dried and de-oiled compressed air
TEMPERATURE	-30°C +105°C
PRESSURE	≤16 Bar
SPEED	≤1.0 m/sec

Note: The above data are maximum values and cannot be used at the same time.

SURFACE ROUGHNESS

Rmax

Sliding Surface	ØD	≤4 µm
-----------------	----	-------

INSTALLATION

K25 is pushed onto the piston rod on the clamping flange towards the rod and fixed by fastening. The nut has to be secured. The sliding surface and the cylinder bore should be oiled with oil that must not go into the reaction with the sealing element during the installation process. Special precautions must be taken at the end of the strokes to avoid damaging of the sealing lips.

NOTES

For special applications that require high temperatures, K25 can be produced in FKM.

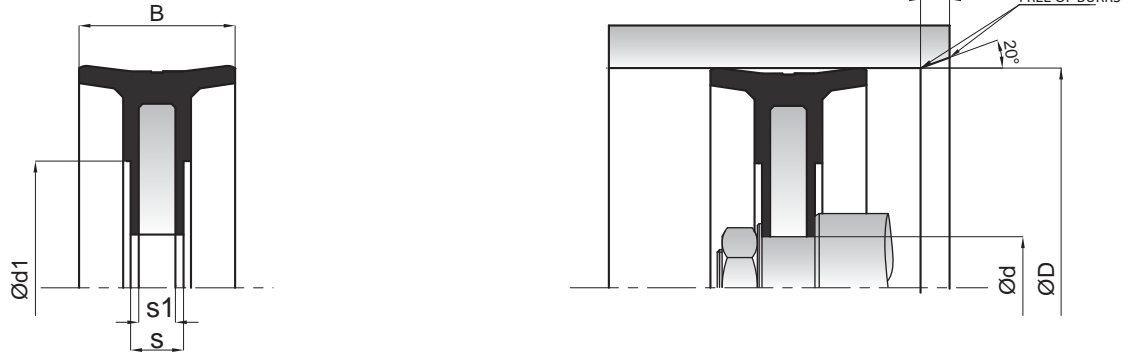

KASTAŞ NO	D (H11)	d (h9)	B	d1	s1	s
K25-020	20	5.2	8	12.2	1	1.4
K25-025	25	8	12	14.5	3	4
K25-026	26	8	12	15.5	3	4
K25-032	32	8	15	16	3	4
K25-035	35	8	15	19	3	4
K25-036	36	8	15	20	3	4
K25-040	40	10	18	23	4	5
K25-050	50	10	18	29	4	5
K25-060	60	12	22	36.8	4	5
K25-062	62	15	22	39	5	6
K25-063	63	12	22	40.5	5	6
K25-070	70	12	22	47	5	6
K25-075	75	15	22	52	5	6
K25-080	80	16	25	55	5	6.5
K25-090	90	16	25	65	5	6.5
K25-100	100	16	25	75	5	6.5
K25-110	110	18	25	85	6	7.5
K25-125	125	20	30	90	8	10
K25-140	140	20	30	95	10	12
K25-150	150	20	30	105	10	12
K25-160	160	27	31	115	10	12
K25-180	180	27	31	135	10	12
K25-190	190	20	30	160.4	10	12
K25-200	200	27	35	150	12	15
K25-250	250	30	35	200	12	16.5
K25-320	320	36	40	278.5	15	18.6
K25-400	400	40	50	320	20	23



K50 is a single acting pneumatic piston seal designed to have asymmetrical profile with shorter and thinner dynamic lip.

PRODUCT ADVANTAGES

- Secure seating due to the longer and thicker static sealing lip
- Low friction and good sealing performance due to the seal geometry
- Wide range of dimensions
- Simple groove design

APPLICATION

Standard pneumatic cylinders.

MATERIAL		CODE
NBR	80 SHORE A	NB8001
PU	80 SHORE A	PU8001

OPERATING CONDITIONS	
NBR	
MEDIA	Prepared, dried and de-oiled compressed air
TEMPERATURE	-30°C +105°C
PRESSURE	≤12 Bar
SPEED	≤1.0 m/sec
PU	
MEDIA	Dried compressed air
TEMPERATURE	-30°C +80°C
PRESSURE	≤16 Bar
SPEED	≤1.0 m/sec

Note: The above data are maximum values and cannot be used at the same time.

SURFACE ROUGHNESS		Rmax
Sliding Surface	ØD	≤4 µm
Groove Base	Ød	≤10 µm
Groove Flanks	B	≤15 µm

INSTALLATION

K50 can be snapped by hand into the housing grooves provided. In case of using an assembly tool make sure that it is of soft material and have no sharp edges. Before installation the sealing element must be oiled with system oil. Special lubrication should be used on the sliding surface in case of having dried media.

NOTES

For special applications that require high temperatures, K50 can be produced in FKM. We recommend using guide ring or guide rings with K50 piston seal.

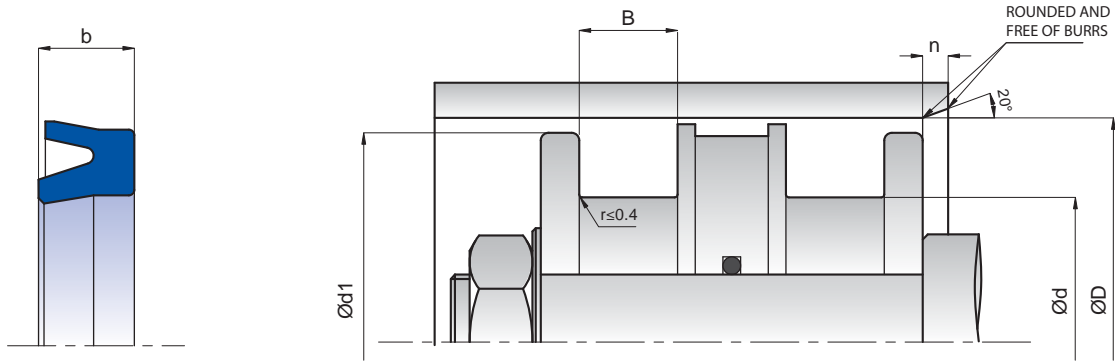

KASTAŞ NO	NBR	PU	D (H11)	d (h9)	B (-0/+0.2)	b	d1 (-0/+0.2)
K50-016	NBR	PU	16	10	3.5	3	15
K50-024	NBR		24	16	6	5.5	23
K50-025/1	NBR		25	17	6	5.5	24
K50-032	NBR	PU	32	24	6	5.5	30.5
K50-038		PU	38.1	30.16	7.64	7.14	36.6
K50-040	NBR	PU	40	30	7.5	7	38.5
K50-042		PU	42	30	11	10	40.5
K50-050/1	NBR	PU	50	36	7.5	7	48.5
K50-050/3		PU	50	39.29	10.52	9.52	48.5
K50-050	NBR	PU	50	40	7.5	7	48.5
K50-050/4		PU	50.8	40.54	7.64	7.14	49.3
K50-053		PU	53.97	44.45	6.85	6.35	52.47
K50-057		PU	57.15	44.45	8.93	7.93	55.65
K50-060	NBR		60	47	9	9	58.5
K50-063	NBR	PU	63	53	7.5	7	61.5
K50-063/1		PU	63.1	46.3	8.1	7.6	61.6
K50-063/4		PU	63.5	50	8.95	7.95	48.5
K50-063/3		PU	63.5	51.19	11.31	10.31	62
K50-066		PU	66.67	57.15	8.94	7.94	65.17
K50-069		PU	69.85	53.97	10.52	9.52	68.35
K50-076		PU	76.2	58.3	14.89	13.89	74.7
K50-080	NBR	PU	80	68	9.5	8.5	78.5
K50-082		PU	82.55	70.64	9.73	8.73	81.05
K50-100	NBR	PU	100	88	9.5	8.5	98
K50-101		PU	101.6	83.56	13.7	12.7	99.6
K50-115	NBR		115	100	11	10	113
K50-125/1		PU	125	105	9.25	8.25	123
K50-125	NBR	PU	125	110	11	10	123
K50-127/1		PU	127	107.15	18.06	17.06	125
K50-127		PU	127	107.95	12.81	11.81	125
K50-152		PU	152.4	134.94	20.05	19.05	150.4
K50-158		PU	158	146	9.5	8.5	156
K50-160/1		PU	160	140	9.25	8.25	158
K50-160		PU	160	140	15	14	158
K50-180		PU	180	160	13	12	178
K50-200		PU	200	180	15	14	198
K50-203		PU	203.2	182.56	23.33	22.22	201.2
K50-250		PU	250	226	17	16	248
K50-254		PU	254	223.83	27.1	26.1	252
K50-320		PU	320	295	18	17	317



K54 is a double acting pneumatic piston seal designed to be used in low axial housing grooves.

PRODUCT ADVANTAGES

- Easy installation
- Wide range of dimensions
- Low friction
- Rounded sealing geometry and flexible centre part give good tightness
- Low axial housing heights

APPLICATION

Short stroke cylinder and valves.

MATERIAL	CODE	
NBR	70 SHORE A	NB7001

OPERATING CONDITIONS	
MEDIA	Prepared, dried and de-oiled compressed air
TEMPERATURE	-30°C +105°C
PRESSURE	≤12 Bar
SPEED	≤1.0 m/sec

Note: The above data are maximum values and cannot be used at the same time.

SURFACE ROUGHNESS		R _{max}
Sliding Surface	∅D	≤4 μm
Groove Base	∅d	≤10 μm
Groove Flanks	B	≤15 μm

INSTALLATION

It can be assembled into one piece piston by hand. It is very important that the assembly tools must be of soft material and have no sharp edges. Before installation the wiper must be oiled with system oil.

NOTES

Small axial housing make K54 to be used in short stroke cylinders. For special applications that require high temperatures, K54 can be produced in FKM.

K54

PNEUMATIC PISTON SEAL

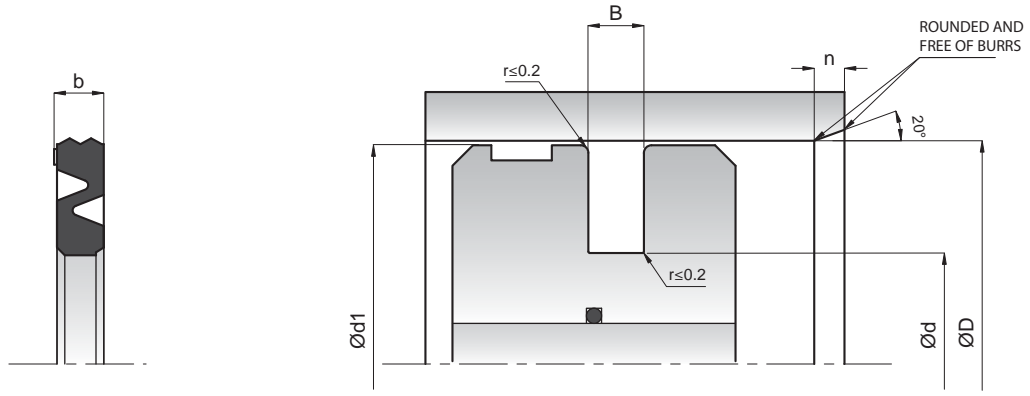

KASTAŞ NO	D (H11)	d (h9)	B (-0/+0.2)	b	d1 (±0.1)
K54-012	12	7	2.5	2.1	11.6
K54-016	16	9	2.5	2.1	13.6
K54-020	20	13	2.5	2.1	19.6
K54-025	25	18	2.5	2.1	24.6
K54-028	28	19	3	2.5	27.6
K54-030	30	21	3	2.5	29.6
K54-032	32	23	3	2.5	31.6
K54-035	35	26	3	2.5	34.5
K54-040	40	31	3	2.5	39.5
K54-045	45	36	3	2.5	44.5
K54-050	50	41	3	2.5	49.5
K54-060	60	44	4	3.4	59.5
K54-063	63	51	4	3.4	62.5
K54-070	70	58	4	3.4	69.5
K54-080	80	68	4	3.4	79.5
K54-100	100	88	4	3.4	99.4
K54-125	125	110	5	4.4	124.4

Please contact our customer service for the dimensions out of our stock list.

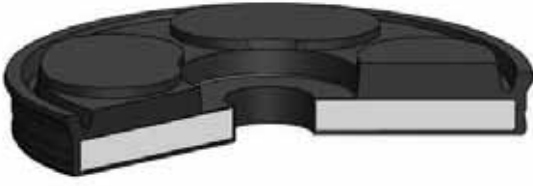

K55 is a single acting complete piston seal which consists of an aluminium plate vulcanized with elastomeric nitrile rubber using special production methods.

PRODUCT ADVANTAGES

- Ready to fit complete piston
- Reliable pressure application at the end of stroke by the venting passages.
- Low friction and smooth running due to sealing lip geometry
- Easily fastened to the piston rod without using additional sealing elements
- Economical sealing solution

APPLICATION

Standard pneumatic cylinders and after market.

MATERIAL		CODE
NBR	70 SHORE A	NB7001
ALUMINIUM		AL9901

OPERATING CONDITIONS	
MEDIA	Prepared, dried and de-oiled compressed air
TEMPERATURE	-30°C +105°C
PRESSURE	≤12 Bar
PEED	≤1.0 m/sec

Note: The above data are maximum values and cannot be used at the same time.

SURFACE ROUGHNESS

Rmax

Sliding Surface

≤4 µm

INSTALLATION

K55 is pushed onto the piston rod on the clamping flange towards the rod and fixed by fastening. The nut has to be secured. The sliding surface and the cylinder bore should be oiled with oil that must not go into the reaction with the sealing element during the installation process.

NOTES

For special applications that require high temperatures, K55 can be produced in FKM.

K55

PNEUMATIC PISTON SEAL

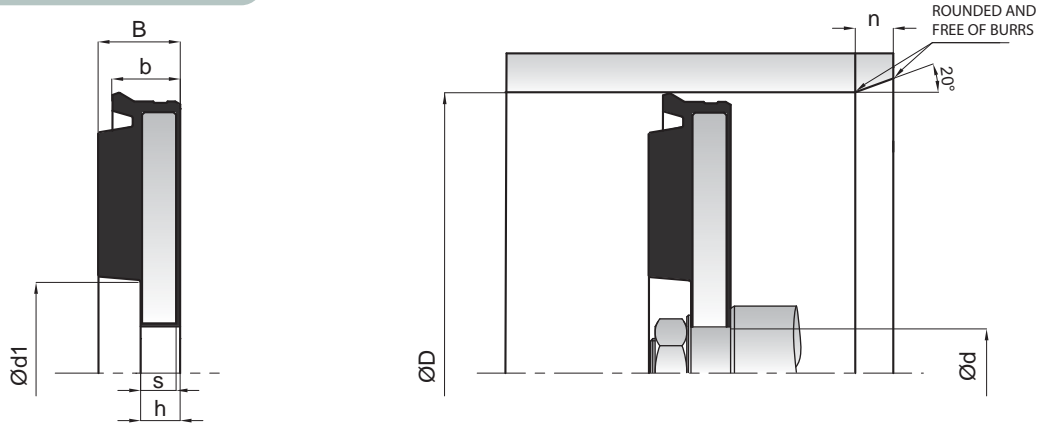

KASTAŞ NO	D (H11)	d (h10)	B	d1 (±0.2)	b	s	h
K55-016	16	4.5	4.4	6.9	3.4	2	2.3
K55-020	20	6	5.5	9.4	4.4	2.5	2.8
K55-025	25	7	6.4	10.8	5.4	3	3.5
K55-032	32	8	7.5	12.5	6	3	3.5
K55-040	40	8	8.5	17	7	4	4.5
K55-050	50	10	10	26	8	4	4.5
K55-063	63	12	10	26	8	4	4.5
K55-080	80	16	11.4	30	9	5	5.5
K55-100	100	20	12.9	35	10.9	6	6.5

Please contact our customer service for the dimensions out of our stock list.



K57 is a double acting complete piston seal which consists of an aluminium plate vulcanized with elastomeric nitrile rubber using special production methods.

PRODUCT ADVANTAGES

- Ready to fit complete piston
- Reliable pressure application at the end of stroke by the venting passages
- Low friction and smooth running due to sealing lip geometry
- Easily fastened to the piston rod without using additional sealing elements
- Economical sealing solution

APPLICATION

Standard pneumatic cylinders and after market.

MATERIAL		CODE
NBR	70 SHORE A	NB7001
ALUMINIUM		AL9901

OPERATING CONDITIONS	
MEDIA	Prepared, dried and de-oiled compressed air
TEMPERATURE	-30°C +105°C
PRESSURE	≤12 Bar
SPEED	≤1.0 m/sec

Note: The above data are maximum values and cannot be used at the same time.

SURFACE ROUGHNESS

R_{max}

Sliding Surface

≤4 μm

INSTALLATION

K57 is pushed onto the piston rod on the clamping flange towards the rod and fixed by fastening. The nut has to be secured. The sliding surface and the cylinder bore should be oiled with oil that must not go into the reaction with the sealing element during the installation process.

NOTES

For special applications that require high temperatures, K57 can be produced in FKM.

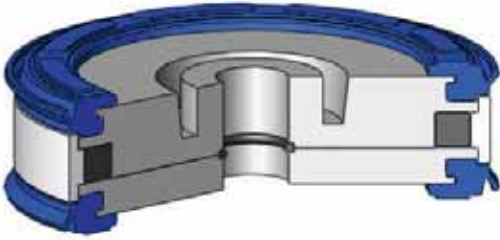

K58 is five piece double acting sealing set consists of aluminium body, two elastomeric sealing elements, one guide ring, one magnet and an O-ring for the inner sealing.

PRODUCT ADVANTAGES

- Ready to fit complete piston
- Low friction and smooth running due to sealing lip geometry
- Easily fastened to the piston rod without using additional sealing elements
- Static seal on the inside diameter
- Easy installation
- Long service life

APPLICATION

All pneumatic cylinders in need of stroke control.

MATERIAL		CODE
PU	80 SHORE A	PU9201
POM		PM9901
ALUMINIUM		AL9901
MAGNET		MK9901
NBR	70 SHORE A	NB7001

OPERATING CONDITIONS

MEDIA	Prepared, dried and de-oiled compressed air
TEMPERATURE	-30°C +80°C
PRESSURE	≤16 Bar
SPEED	≤1.0 m/sec

Note: The above data are maximum values and cannot be used at the same time.

SURFACE ROUGHNESS

R_{max}

Sliding Surface

≤4 μm

INSTALLATION

K58 is pushed onto the piston rod on the clamping flange towards the rod and fixed by fastening. The nut has to be secured. The sliding surface and the cylinder bore should be oiled with oil that must not go into the reaction with the sealing element during the installation process.

NOTES

For special applications that require high temperatures, K58 can be produced in FKM.



K59 is a single acting pneumatic piston seal designed to have asymmetrical profile with shorter and thinner dynamic lip.

PRODUCT ADVANTAGES

- Easy installation
- Secure seating due to the longer and thicker static sealing lip
- Simple groove design and low axial housing height
- High sealing effect with cushioning applications

APPLICATION

Standard pneumatic cylinders.

MATERIAL		CODE
NBR	80 SHORE A	NB8001
PU	80 SHORE A	PU8001

OPERATING CONDITIONS

NBR

MEDIA	Prepared, dried compressed air
TEMPERATURE	-30°C +105°C
PRESSURE	≤12 Bar
SPEED	≤1.0 m/sec

POLYURETHAN

MEDIA	Dried compressed air
TEMPERATURE	-30°C +80°C
PRESSURE	≤16 Bar
SPEED	≤1.0 m/sec

Note: The above data are maximum values and cannot be used at the same time.

SURFACE ROUGHNESS

		Rmax
Sliding Surface	∅D	≤4 μm
Groove Base	∅d	≤10 μm
Groove Flanks	B	≤15 μm

INSTALLATION

K59 can be snapped by hand into the housing grooves provided. In case of using an assembly tool make sure that it is of soft material and have no sharp edges. Before installation the sealing element must be oiled with system oil. Special lubrication should be used on the sliding surface in case of having dried media.

NOTES

For special applications that require high temperatures, K59 can be produced in FKM. We recommend using guide ring or guide rings with K59 piston seal.

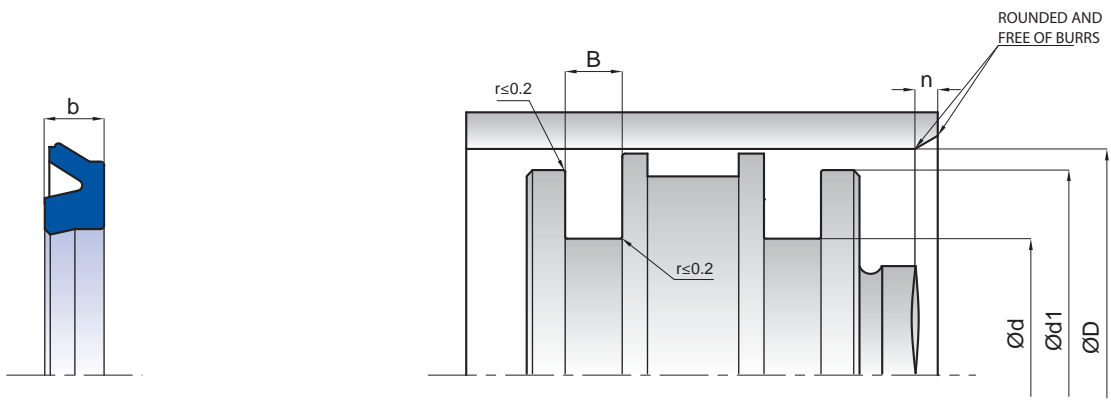

KASTAŞ KOD	NBR	PU	D (H11)	d (h9)	B (-0/+0,2)	d1 (-0/+0,2)	b
K59-008	NBR		8	4.8	2.7	7.6	2.3
K59-010	NBR		10	6	3	9.6	2.55
K59-012	NBR		12	7	3	11.6	2.55
K59-016	NBR		16	10	3	15.6	2.55
K59-020	NBR		20	14	3	19.6	2.55
K59-025	NBR		25	19	3.5	24.4	3.25
K59-032	NBR	PU	32	24	3.5	31.4	3.25
K59-040	NBR	PU	40	32	3.5	39.4	3.25
K59-050	NBR	PU	50	42	3.5	49.4	3.25
K59-063	NBR	PU	63	53	4.5	62.4	4.25
K59-080	NBR	PU	80	70	4.5	79.4	4.25
K59-100	NBR	PU	100	90	4.5	99.4	4.25
K59-125		PU	125	105	8.5	123.8	8.25
K59-160		PU	160	140	8.5	158.8	8.25

Please contact our customer service for the dimensions out of our stock list.



K62 is a double acting pneumatic piston seal designed to work in low axial housing heights.

PRODUCT ADVANTAGES

- Easy installation
- Low friction
- Superior sealing effect

APPLICATION

Short stroke pneumatic cylinders and valves.

MATERIAL	CODE	
NBR	70 SHORE A	NB7001

OPERATING CONDITIONS	
MEDIA	Prepared, dried and de-oiled compressed air
TEMPERATURE	-30°C +105°C
PRESSURE	≤12 Bar
SPEED	≤1.0 m/sec

Note: The above data are maximum values and cannot be used at the same time.

SURFACE ROUGHNESS		Rmax
Sliding Surface	∅D	≤4 μm
Groove Base	∅d	≤10 μm
Groove Flanks	B	≤15 μm

INSTALLATION

K62 can be snapped by hand into the housing grooves provided. In case of using an assembly tool make sure that it is of soft material and have no sharp edges. Before installation the sealing element must be oiled with system oil. Special lubrication should be used on the sliding surface in case of having dried media.

NOTES

For special applications that require high temperatures, K62 can be produced in FKM.



K63 is a double acting pneumatic piston seal designed to work in low axial housing heights.

PRODUCT ADVANTAGES

- Easy installation
- Low friction
- Superior sealing effect

APPLICATION

Short stroke pneumatic cylinders and valves.

MATERIAL		CODE
NBR	70 SHORE A	NB7001

OPERATING CONDITIONS	
MEDIA	Prepared, dried and de-oiled compressed air
TEMPERATURE	-30°C +105°C
PRESSURE	≤12 Bar
SPEED	≤1.0 m/sec

Note: The above data are maximum values and cannot be used at the same time.

SURFACE ROUGHNESS		Rmax
Sliding Surface	ØD	≤4 µm
Groove Base	Ød	≤10 µm
Groove Flanks	B	≤15 µm

INSTALLATION

K63 can be snapped by hand into the housing grooves provided. In case of using an assembly tool make sure that it is of soft material and have no sharp edges. Before installation the sealing element must be oiled with system oil. Special lubrication should be used on the sliding surface in case of having dried media.

NOTES

For special applications that require high temperatures, K63 can be produced in FKM.

K63

PNEUMATIC PISTON SEAL

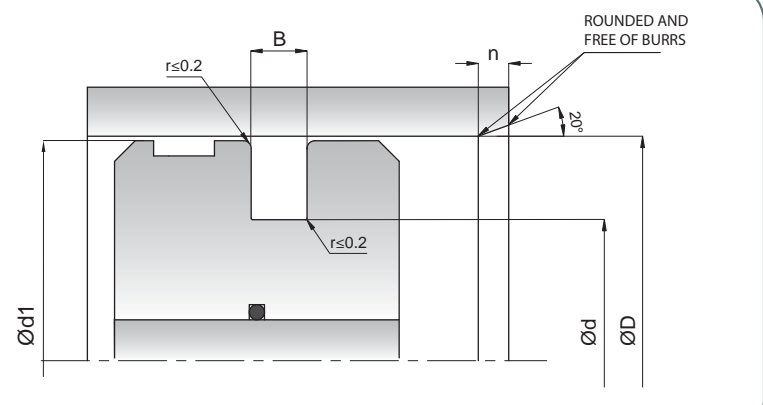
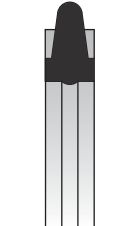

KASTAŞ NO	D (H11)	d (h9)	B (-0/+0.2)	d1 (± 0.1)
K63-012	12	7.4	1.8	11.7
K63-016	16	11.4	1.8	15.7
K63-020	20	14	2.4	19.5
K63-025	25	17	3.2	24.5

Please contact our customer service for the dimensions out of our stock list.



20 horizontal light gray lines for writing.

GUIDE ELEMENTS



Guide elements do have very important role for sealing elements to function properly in hydraulic and pneumatic systems. The transverse forces in hydraulic and pneumatic cylinders will cause momentums to occur inside the system.

There is need for guide elements to absorb such momentums in order to prevent the damaging factors to the sealing elements as well as to the system. Guide elements are installed in the piston and gland caps to absorb the radial forces-moments in the system preventing metal to metal contact with piston to the cylinder bore and rod to the gland cap. The elastic deformation of the components under the load (deflection of the guide element, bending of the shaft, stretching of the cylinder) creates an angular deviation between the piston and bore or rod and gland cap. Calculation based on the parallel axis generally gives incorrect results. In this respect it is vital to take this into consideration when calculating the guide elements.

Nowadays most of the cylinders have non metal guide elements instead of metal guide elements. Non metallic guide elements do have very low friction coefficient, high bearing capacity, excellent cushioning effect and able to work in vibrated systems. They are easily installed into open grooves, prevents hydrodynamic pressure and diesel effect, able to absorb the angular deviations between the piston-bore and rod-gland cap and economical guiding solution which make them used widely in the applications.

During the application of the non metallic guide strips the gap (k) should be checked according to our catalogue information prior to installation to prevent hydrodynamic pressure and to increase the life-span.

MATERIALS USED IN GUIDE ELEMENTS AND THEIR CHARACTERISTICS

Today the cylinders are expected to work with high speed, high forces without any problems during the application. Operating temperature, sliding speed, media and the operating forces of the system are important factors in choosing the guide element to achieve these expectations. Most common non metallic guide element materials are special filled PTFE, special filled or pure Polyacetal (POM), fiber or polyester resin. Utilization of the metallic guide elements reduced over the past years but still they are being used for some applications.

Our guide elements can be divided into three main categories. Figure 33 shows the surface contact pressure values of these. Surface contact pressure resistance of the non metallic guide element decreases when the sliding speed and temperature increases (Figure 33 and Figure 34). In this respect the height calculation of the guide element should be done according to the maximum system temperature and speed information.

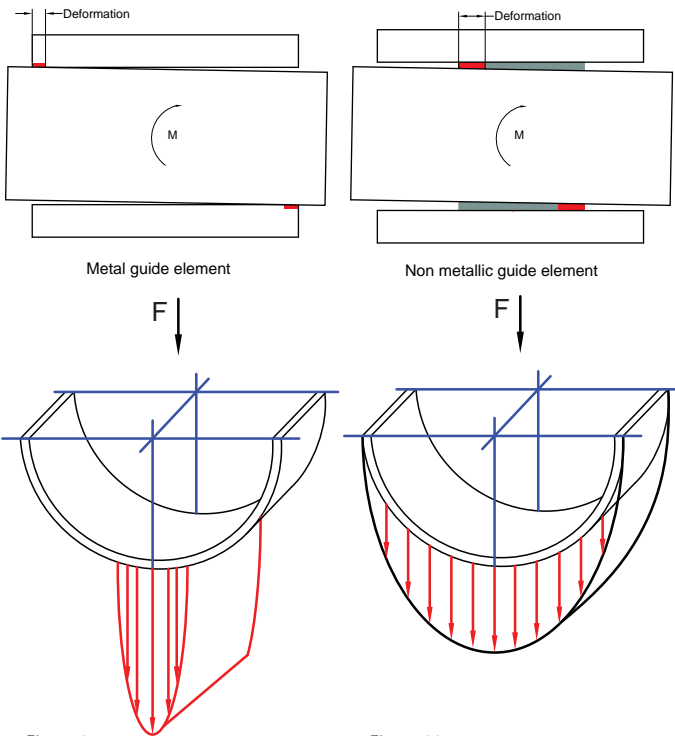

Figure 31 Load distribution with a metal guide element

Figure 32 Load distribution with non metallic guide element

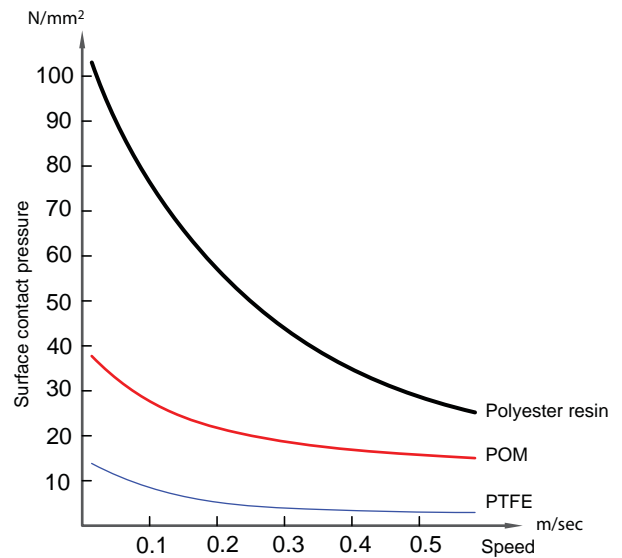

Figure 33 Surface contact pressure vs speed at 60°C

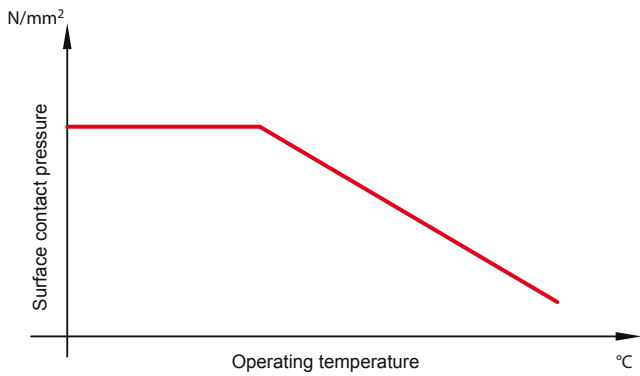

Figure 34
Surface contact pressure vs operating temperature for POM guide elements

POM GUIDE ELEMENTS

Polyacetal guide elements generally used with glass additive or pure form. They have a wide range of usage as a result of low service costs. Surface contact pressure of POM guide elements decreases the same level as the other thermoplastic materials when the temperatures go above +60°C. POM material has light and medium load bearing capacity.

POLYESTER RESIN GUIDE ELEMENTS

Polyester resin guide elements have improved function compared to straight metal guide elements thanks to their elastic structure. The low tension increase in the edge area and the elastic properties makes these guide elements to withstand higher surface loads. The surface contact pressure and the characteristics under high operating temperature is greatly influenced by the composition of polyester resin-based material. Special texture of the polyester resin reduces the friction forces and prevents the break off material during the application. The radial load is distributed homogenously on these guide elements which enables to work on insufficient lubricated applications. Polyester resin guide elements have medium and high load bearing capacity.

PTFE GUIDE ELEMENTS

PTFE guide elements are commonly used in applications that has high operating temperature, aggressive media and in need of low friction forces. Bronze, carbon and MoS₂ additives improve the mechanical properties of PTFE material depending on the application. PTFE guide elements are being used with other high load bearing capacity guide elements on some particular applications. PTFE mainly absorbs the foreign particles in the system in such applications to prevent damaging of the cylinder bore or rod and not to stick these particles into harder guide elements. It has light load bearing capacity.

GUIDE ELEMENT HEIGHT&WIDTH CALCULATIONS

The elastic deformation of the components under the load (deflection of the guide element, bending of the shaft, extending/shrinking of the cylinder) creates an angular deviation between the piston and bore or rod and gland cap. Calculation based on the parallel axis generally gives incorrect results. In this respect it is vital to take this into consideration when calculating the guide elements.

Geometric consideration (angular deviation, additional force applications to the system, etc) should be taken into account when calculating the transverse load applied on the guide element and also the elastic deformation of all components involved (deflection of the guide element, bending of the shaft, stretching of the cylinder, etc). In this respect while making the calculations a safety factor (generally around 2) should be identified.

In long slender cylinders the permissible transverse force is limited by the bending strength of the rod and other factors. The general assumption that about 10% to 15% of the hydraulic force is applied as a transverse load.

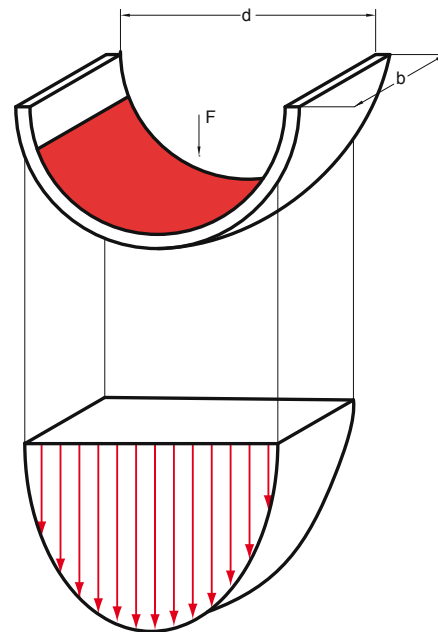

Figure 35
Width calculation of guide element

$$b = \frac{F \times f}{d \times Pt}$$

b = Guide strip width (mm)

F = Transverse force (N)

f = Safety factor (f ≈ 2)

Pt = Permissible surface contact pressure (N/ mm²)

d = Nominal diameter of rod or piston (mm)

It is not required to have metal to metal contact with piston-bore and rod-gland cap. That is why under the transverse forces, maximum angular deviation for the guide element should be less than the permissible sealing gap defined in the catalogue.

GUIDE LENGTH CALCULATIONS IN GUIDE STRIP

L = Guide strip length (mm)
 d = Nominal diameter of rod (mm)

D = Nominal diameter of piston (mm)
 a = Cross-sectional thickness of the guide strip (mm)

Piston Application

$$L = \frac{3.14 \times (D-a)}{1.01} - 1.2 \text{ mm}$$

Rod Application

$$L = \frac{3.14 \times (d+a)}{1.01} - 1.2 \text{ mm}$$

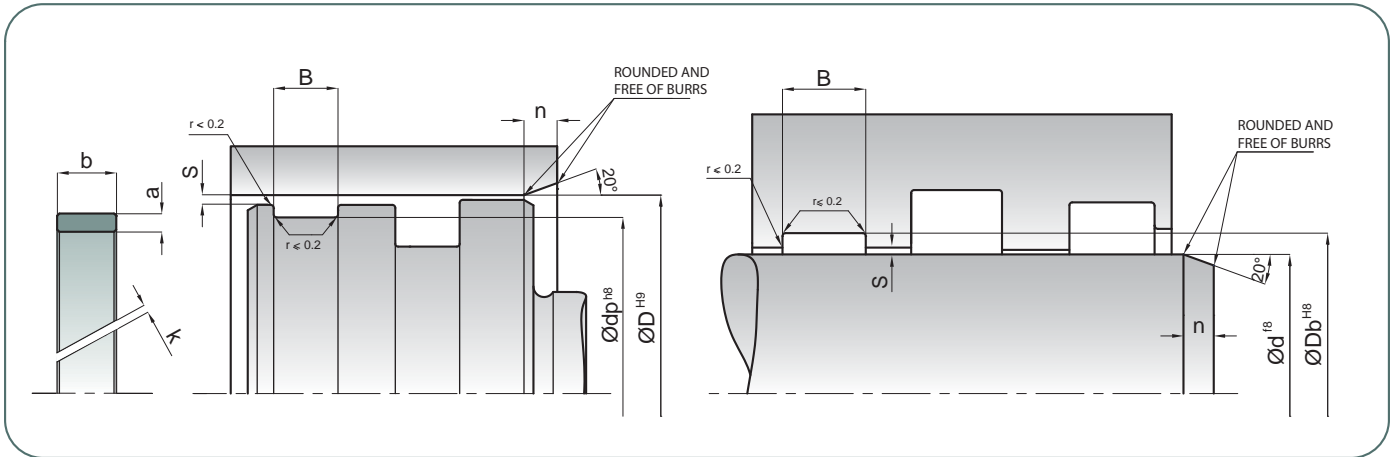
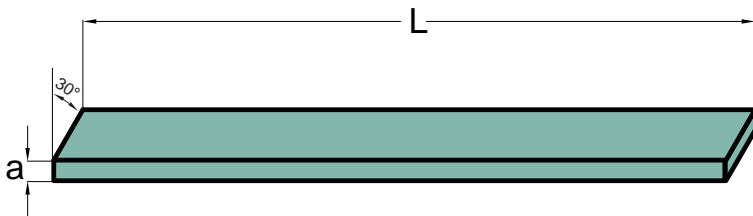
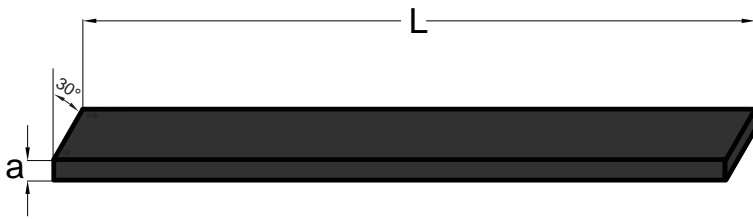
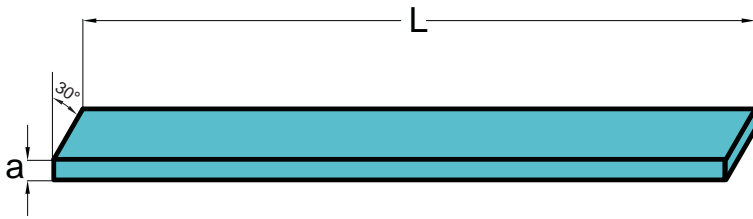



K68 is a guide ring designed to be used for rod applications.

PRODUCT ADVANTAGES

- Easy, snap-in fitting
- Medium load-bearing capacity
- Prevents hydrodynamic pressure due to the K interval
- Very good dimension stability during operation temperatures
- Chamfered edges prevent pressing into the corner radii of the groove
- Wide range of dimensions
- Economical guiding solution

APPLICATION

Construction machinery, cranes, injection moulding machines, agricultural machinery, light to medium duty cylinders.

MATERIAL	CODE
POM special filled	PM9902

OPERATING CONDITIONS			
MEDIA	Mineral oils (DIN 51524)	HFA and HFB	HFC
TEMPERATURE	-30°C +125°C	+5°C +50°C	-30°C +40°C
CONTACT PRESSURE	≤40 N/mm ²	≤40 N/mm ²	≤40 N/mm ²
SPEED	≤1.0 m/sec	≤1.0 m/sec	≤1.0 m/sec

Note: The above data are maximum values and cannot be used at the same time.

SURFACE ROUGHNESS		Ra	Rmax
Sliding Surface	Ød	≤0.4 µm	≤3.2 µm
Groove Base	ØD	≤2.5 µm	≤10 µm
Groove Flanks	B	≤3.2 µm	≤16 µm

INSTALLATION

Easily assembled into the housing by hand. It is very important that the assembly tools must be of soft material and have no sharp edges. Before installation the rod guide ring must be oiled with system oil.

NOTES

During design stage of the cylinder, K68 guide ring should be placed where it has direct contact with the media. K68 is not suitable for dry working conditions. Surface contact pressure value might drop due to the temperature increase.

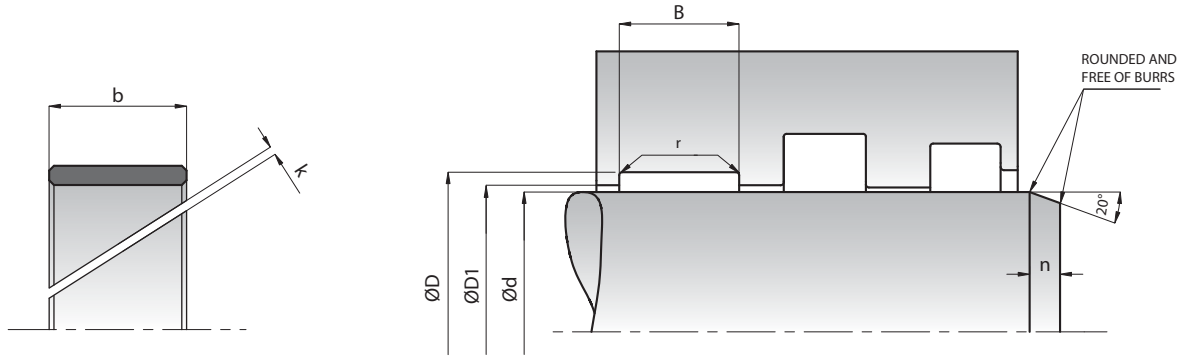

KASTAŞ NO	d (f8)	D (H8)	b	B (-0/+0.2)	D1 (H9)	r	k
K68-016	16	20	9.4	9.6	16.4	0.2	1
K68-016/1	16	19	5.8	6	16.4	0.2	1
K68-018	18	22	9.4	9.6	18.4	0.2	1
K68-020	20	24	9.4	9.6	20.4	0.2	1
K68-020/2	20	26	9.5	9.7	20.4	0.2	1
K68-020/1	20	26	3.8	4	20.4	0.2	1
K68-022	22	26	9.4	9.6	22.5	0.2	1
K68-022/1	22	25	4	4.2	22.5	0.2	1
K68-025	25	31	9.4	9.6	25.5	0.2	1
K68-025/1	25	29	9.4	9.6	25.5	0.2	1
K68-025/2	25	30	5.4	5.6	25.5	0.2	1
K68-026	26	32	9.8	10	26.5	0.2	1
K68-028	28	32	9.5	9.7	28.5	0.2	1
K68-028/2	28	33	6.2	6.4	28.5	0.2	1
K68-028/3	28	33	5.5	5.7	28.5	0.2	1
K68-028/4	28	34	9.5	9.7	28.5	0.2	1
K68-030	30	35	15	15.2	30.5	0.2	1
K68-030/1	30	34	9.5	9.7	30.5	0.2	1
K68-030/2	30	36	9.3	9.5	30.5	0.2	1
K68-030/3	30	35	9.5	9.7	30.5	0.2	1
K68-030/4	30	35	8	8.2	30.5	0.2	1
K68-030/5	30	35	5.4	5.6	30.5	0.2	1
K68-032	32	36	9.5	9.7	32.5	0.2	1
K68-032/1	32	38	9.4	9.6	32.5	0.2	1
K68-035	35	40	15	15.2	35.5	0.2	1
K68-035/1	35	39	9.5	9.7	35.5	0.2	1
K68-035/2	35	40	9.7	9.9	35.5	0.2	1
K68-035/3	35	41	9.4	9.6	35.5	0.2	1
K68-035/4	35	40	5.4	5.6	35.5	0.2	1
K68-035/6	35	40	9.5	9.7	35.5	0.2	1
K68-035/8	35	39	6.3	6.5	35.5	0.2	1
K68-036	36	40	9.5	9.7	36.5	0.2	1
K68-036/1	36	42	9.6	9.8	36.5	0.2	1
K68-036/3	36	41	5.4	5.6	36.5	0.2	1
K68-036/2	36	41	9.5	9.7	36.5	0.2	1
K68-038/2	38	42	4	4.2	38.5	0.2	1
K68-038	38	42	9.4	9.6	38.5	0.2	1
K68-040	40	45	15	15.2	40.5	0.2	1.5
K68-040/1	40	44	9.5	9.7	40.5	0.2	1.5
K68-040/2	40	46	9.6	9.8	40.5	0.2	1.5
K68-040/3	40	45	9.5	9.7	40.5	0.2	1.5
K68-040/8	40	44	6.3	6.5	40.5	0.2	1.5
K68-040/5	40	45	4.8	5	40.5	0.2	1.5
K68-040/6	40	45	5.4	5.6	40.5	0.2	1.5
K68-040/4	40	45	20	20.2	40.5	0.2	1.5
K68-040/7	40	46	12.8	13	40.5	0.2	1.5
K68-040/9	40	45	9.6	9.8	40.5	0.2	1.5
K68-044.45	44.45	50.8	19.05	19.25	44.95	0.2	1.5
K68-045	45	50	15	15.2	45.5	0.2	1.5
K68-045/1	45	51	9.5	9.7	45.5	0.2	1.5

Please contact our customer service
for the dimensions out of our stock list.

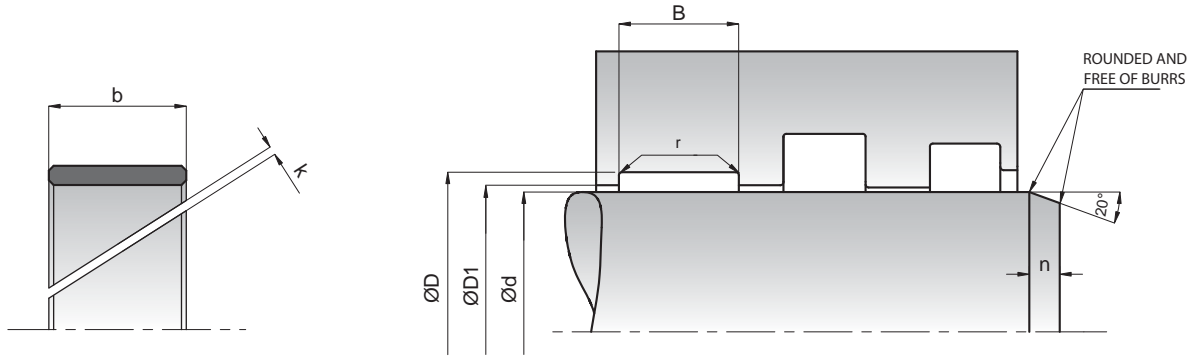

KASTAŞ NO	d (f8)	D (H8)	b	B (-0/+0.2)	D1 (H9)	r	k
K68-045/2	45	50	9.5	9.7	45.5	0.2	1.5
K68-045/3	45	51	12.5	12.7	45.5	0.2	1.5
K68-045/5	45	50	5.4	5.6	45.5	0.2	1.5
K68-048	48	54	9.6	9.8	48.5	0.2	1.5
K68-050	50	55	15	15.2	50.5	0.2	1.5
K68-050/1	50	56	9.5	9.7	50.5	0.2	1.5
K68-050/2	50	56	12.5	12.7	50.5	0.2	1.5
K68-050/3	50	55	8	8.2	50.5	0.2	1.5
K68-050/4	50	55	20	20.2	50.5	0.2	1.5
K68-050/5	50	55	9.5	9.7	50.5	0.2	1.5
K68-050/6	50	55	5.4	5.6	50.5	0.2	1.5
K68-050.8	50.8	57.15	19.05	19.25	51.3	0.2	1.5
K68-055	55	60	15	15.2	55.5	0.2	2
K68-055/1	55	61	9.5	9.7	55.5	0.2	2
K68-055/2	55	60	8	8.2	55.5	0.2	2
K68-055/3	55	60	20	20.2	55.5	0.2	2
K68-055/4	55	61	12.5	12.7	55.5	0.2	2
K68-055/5	55	60	9.5	9.7	55.5	0.2	2
K68-055/6	55	60	5.4	5.6	55.5	0.2	2
K68-055/7	55	60	5.6	5.8	55.5	0.2	2
K68-055/8	55	60	9.7	9.9	55.5	0.2	2
K68-056	56	62	12.5	12.7	56.5	0.2	2
K68-056/1	56	60	9.6	9.8	56.5	0.2	2
K68-056/2	56	61	9.5	9.7	56.5	0.2	2
K68-056/3	56	60	7.9	8.1	56.5	0.2	2
K68-056/4	56	62	20	20.2	56.5	0.2	2
K68-058	58	63	9.5	9.7	58.5	0.2	2
K68-060	60	65	15	15.2	60.5	0.2	2
K68-060/1	60	66	12.5	12.7	60.5	0.2	2
K68-060/2	60	65	9.5	9.7	60.5	0.2	2
K68-060/8	60	64	10	10.2	60.5	0.2	2
K68-060/7	60	64	19.3	19.5	60.5	0.2	2
K68-060/6	60	65	5.3	5.5	60.5	0.2	2
K68-060/4	60	65	8	8.2	60.5	0.2	2
K68-060/3	60	65	20	20.2	60.5	0.2	2
K68-060/5	60	66	9.7	9.9	60.5	0.2	2
K68-063	63	69	12.5	12.7	63.5	0.2	2.5
K68-063/2	63	67	6.3	6.5	63.5	0.2	2.5
K68-063/1	63	68	9.5	9.7	63.5	0.2	2.5
K68-063/4	63	69	30	30.5	63.5	0.2	2.5
K68-065	65	70	15	15.2	65.5	0.2	2.5
K68-065/1	65	71	12.5	12.7	65.5	0.2	2.5
K68-065/2	65	70	5.4	5.6	65.5	0.2	2.5
K68-065/3	65	70	6.8	7	65.5	0.2	2.5
K68-067	67	72	5.4	5.6	67.5	0.2	2.5
K68-069.85	69.85	76.2	19.05	19.25	70.05	0.2	2.5
K68-070	70	75	15	15.2	70.5	0.2	2.5
K68-070/1	70	76	12.5	12.7	70.5	0.2	2.5
K68-070/2	70	75	5.4	5.6	70.5	0.2	2.5

KASTAŞ NO	d (f8)	D (H8)	b	B (-0/+0.2)	D1 (H9)	r	k
K68-070/5	70	75	9.5	9.7	70.5	0.2	2.5
K68-070/4	70	76	10	10.2	70.5	0.2	2.5
K68-070/3	70	76	25	25.5	70.5	0.2	2.5
K68-072/1	72	78	12.3	12.5	72.5	0.2	2.5
K68-075	75	80	15	15.2	75.5	0.2	2.5
K68-075/1	75	81	12.5	12.7	75.5	0.2	2.5
K68-075/2	75	80	8	8.2	75.5	0.2	2.5
K68-075/3	75	80	9.5	9.7	75.5	0.2	2.5
K68-075/4	75	80	5.4	5.6	75.5	0.2	2.5
K68-080	80	85	15	15.2	80.5	0.2	2.5
K68-080/1	80	86	12.5	12.7	80.5	0.2	2.5
K68-080/3	80	85	9.5	9.7	80.5	0.2	2.5
K68-080/2	80	84	9.3	9.5	80.5	0.2	2.5
K68-080/5	80	85	19.8	20	80.5	0.2	2.5
K68-080/4	80	86	24.8	25.3	80.5	0.2	2.5
K68-080/7	80	86	30	30.5	80.5	0.2	2.5
K68-085	85	90	15	15.2	85.5	0.2	2.5
K68-085/1	85	91	12.5	12.7	85.5	0.2	2.5
K68-085/2	85	90	5.5	5.7	85.5	0.2	2.5
K68-085/3	85	90	9.7	9.9	85.5	0.2	2.5
K68-086	86	92	12.5	12.7	86.5	0.2	2.5
K68-090	90	95	15	15.2	90.5	0.2	2.5
K68-090/1	90	96	12.5	12.7	90.5	0.2	2.5
K68-090/2	90	95	9.5	9.7	90.5	0.2	2.5
K68-090/4	90	94	15	15.2	90.5	0.2	2.5
K68-090/3	90	95	5.6	5.8	90.5	0.2	2.5
K68-090/7	90	96	30	30.5	90.5	0.2	2.5
K68-095	95	100	15	15.2	95.5	0.2	2.5
K68-095/1	95	101	12.5	12.7	95.5	0.2	2.5
K68-095/2	95	100	9.5	9.7	95.5	0.2	3.5
K68-095/3	95	100	5.4	5.6	95.5	0.2	3.5
K68-100	100	105	15	15.2	100.5	0.2	3.5
K68-100/1	100	106	12.5	12.7	100.5	0.2	3.5
K68-100/2	100	104	15	15.2	100.5	0.2	2.5
K68-100/3	100	105	9.7	9.9	100.5	0.2	3.5
K68-104	104	110	10	10.2	104.6	0.2	3.5
K68-105	105	110	15	15.2	105.6	0.2	3.5
K68-105/1	105	110	8	8.2	105.6	0.2	3.5
K68-105/2	105	110	9.5	9.7	105.6	0.2	3.5
K68-110	110	116	12.5	12.7	110.6	0.2	3.5
K68-110/1	110	115	9.5	9.7	110.6	0.2	3.5
K68-110/2	110	115	20	20.2	110.6	0.2	3.5
K68-115	115	120	15	15.2	115.6	0.2	3.5
K68-115/1	115	121	12.5	12.7	115.6	0.2	3.5
K68-119	119	125	15	15.2	119.6	0.2	3.5
K68-120	120	125	15	15.2	120.6	0.2	3.5
K68-120/1	120	126	12.5	12.7	120.6	0.2	3.5
K68-120/2	120	125	9.5	9.7	120.6	0.2	3.5
K68-125	125	131	12.5	12.7	125.6	0.2	3.5
K68-125/1	125	130	15	15.2	125.6	0.2	3.5
K68-125/2	125	130	7	7.2	125.6	0.2	3.5
K68-130	130	135	15	15.2	130.6	0.2	3.5
K68-130/1	130	136	12.5	12.7	130.6	0.2	3.5
K68-135	135	140	9.5	9.7	135.6	0.2	3.5
K68-135/1	135	140	15	15.2	135.6	0.2	3.5
K68-140	140	145	15	15.2	140.6	0.2	3.5
K68-140/1	140	146	12.5	12.7	140.6	0.2	3.5
K68-146	146	150	10	10.2	146.6	0.2	3.5
K68-150	150	155	15	15.2	150.6	0.2	3.5
K68-150/1	150	156	12.5	12.7	150.6	0.2	3.5
K68-150/4	150	160	34.8	35.3	150.6	0.2	3.5
K68-150/5	150	155	24.8	25.3	150.6	0.2	3.5
K68-150/6	150	156	19	19.2	150.6	0.2	3.5
K68-155	155	160	15	15.2	155.6	0.2	3.5
K68-160	160	165	15	15.2	160.6	0.2	3.5



26 horizontal lines for writing, each with a light gray gradient background.



K69 is a guide ring designed to be used for piston applications.

PRODUCT ADVANTAGES

- Easy, snap-in fitting
- Medium load-bearing capacity
- Prevents hydrodynamic pressure due to the K interval
- Very good dimension stability during operating temperatures
- Chamfered edges prevent pressing into the corner radii of the groove
- Wide range of dimensions
- Economical guiding solution

APPLICATION

Construction machinery, cranes, injection moulding machines, agricultural machinery, light to medium duty cylinders.

MATERIAL	CODE
POM special filled	PM9902

OPERATING CONDITIONS			
MEDIA	Mineral oils (DIN 51524)	HFA and HFB	HFC
TEMPERATURE	-30°C +125°C	+5°C +50°C	-30°C +40°C
CONTACT PRESSURE	≤40 N/mm ²	≤40 N/mm ²	≤40 N/mm ²
SPEED	≤1.0 m/sec	≤1.0 m/sec	≤1.0 m/sec

Note: The above data are maximum values and cannot be used at the same time.

SURFACE ROUGHNESS		Ra	Rmax
Sliding Surface	∅D	≤0.4 μm	≤3.2 μm
Groove Base	∅d	≤2.5 μm	≤10 μm
Groove Flanks	B	≤3.2 μm	≤16 μm

INSTALLATION

Easily assembled into the housing by hand. It is very important that the assembly tools must be of soft material and have no sharp edges. Before installation, the piston guide ring must be oiled with system oil.

NOTES

During design stage of the cylinder, K69 guide ring should be placed where it has direct contact with the media. K69 is not suitable for dry working conditions. Surface contact pressure value might drop due to the temperature increase.

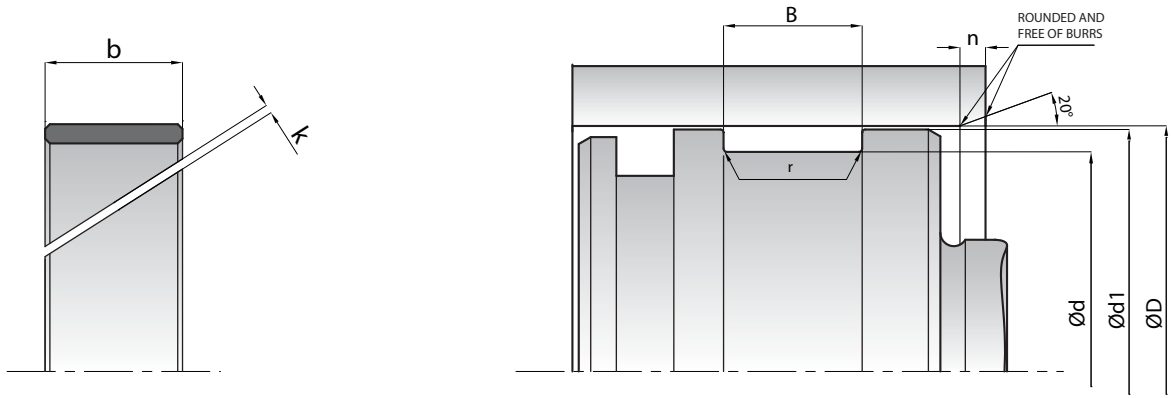

KASTAŞ NO	D (H8)	d (h8)	b	B (-0/+0.2)	d1 (h9)	r	k
K69-020	20	16	9.4	9.6	19.5	0.2	1
K69-025	25	21	9.5	9.7	24.5	0.2	1
K69-025/1	25	21	8	8.2	24.5	0.2	1
K69-025/2	25	22	4	4.2	24.5	0.2	1
K69-030	30	26	9.5	9.7	29.5	0.2	1
K69-030/1	30	25	5.4	5.6	29.5	0.2	1
K69-032	32	28	9.5	9.7	31.5	0.2	1
K69-032/1	32	26	9.8	9.9	31.5	0.2	1
K69-032/3	32	27	5.4	5.6	31.5	0.2	1
K69-033	33	28	5.5	5.7	32.5	0.2	1
K69-034	34	28	9.5	9.7	33.5	0.2	1
K69-035	35	30	15	15.2	34.5	0.2	1
K69-035/1	35	31	9.5	9.7	34.5	0.2	1
K69-035/2	35	29	9.5	9.7	34.5	0.2	1
K69-035/3	35	29	9.8	10	34.5	0.2	1
K69-035/6	35	30	5.4	5.6	34.5	0.2	1
K69-035/7	35	30	8	8.2	34.5	0.2	1
K69-035/5	35	30	9.5	9.7	34.5	0.2	1
K69-040	40	35	15	15.2	39.5	0.2	1
K69-040/1	40	36	9.5	9.7	39.5	0.2	1
K69-040/2	40	34	9.7	9.9	39.5	0.2	1
K69-040/6	40	34	9.5	9.7	39.5	0.2	1
K69-040/3	40	35	5.4	5.6	39.5	0.2	1
K69-040/5	40	35	9.5	9.7	39.5	0.2	1
K69-045	45	40	15	15.2	44.5	0.2	1.5
K69-045/1	45	41	9.5	9.7	44.5	0.2	1.5
K69-045/2	45	40	9.5	9.7	44.5	0.2	1.5
K69-045/3	45	41	10	10.2	44.5	0.2	1.5
K69-045/4	45	39	9.8	10	44.5	0.2	1.5
K69-045/7	45	40	5.4	5.6	44.5	0.2	1.5
K69-045/8	45	40	9.6	9.8	44.5	0.2	1.5
K69-050	50	45	15	15.2	49.5	0.2	1.5
K69-050/1	50	44	9.5	9.7	49.5	0.2	1.5
K69-050/2	50	45	9.5	9.7	49.5	0.2	1.5
K69-050/3	50	45	5.4	5.6	49.5	0.2	1.5
K69-050/4	50	46	15	15.2	49.5	0.2	1.5
K69-050.8	50.8	44.45	19.05	19.25	50.3	0.2	1.5
K69-055	55	50	15	15.2	54.5	0.2	1.5
K69-055/1	55	49	12.5	12.7	54.5	0.2	1.5
K69-055/2	55	50	8	8.2	54.5	0.2	1.5
K69-055/3	55	50	20	20.2	54.5	0.2	1.5
K69-055/4	55	50	9.5	9.7	54.5	0.2	1.5
K69-055/5	55	49	9.3	9.5	54.5	0.2	1.5
K69-055/6	55	49	9.7	9.9	54.5	0.2	1.5
K69-055/9	55	49	9.8	10	54.5	0.2	1.5
K69-055/8	55	50	5.4	5.6	54.5	0.2	1.5
K69-055/7	55	51	9.8	10	54.5	0.2	1.5
K69-057.15	57.15	50.8	19.05	19.25	56.65	0.2	1.5
K69-060	60	55	15	15.2	59.5	0.2	2

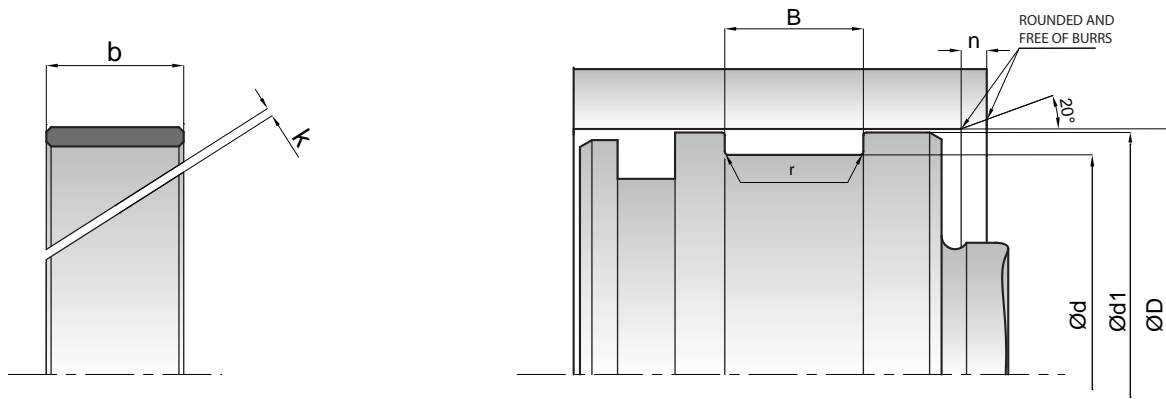

KASTAŞ NO	D (H8)	d (h8)	b	B (-0/+0.2)	d1 (h9)	r	k
K69-060/1	60	54	12.5	12.7	59.5	0.2	2
K69-060/2	60	54	9.3	9.5	59.5	0.2	2
K69-060/4	60	56	9.6	9.8	59.5	0.2	2
K69-060/5	60	56	10	10.2	59.5	0.2	2
K69-060/6	60	55	5.4	5.6	59.5	0.2	2
K69-060/7	60	55	5.6	5.8	59.5	0.2	2
K69-060/8	60	55	9.7	9.9	59.5	0.2	2
K69-060/3	60	55	9.5	9.7	59.5	0.2	2
K69-060/9	60	56	7.9	8.1	59.5	0.2	2
K69-063	63	57	12.5	12.7	62.5	0.2	2
K69-063/1	63	58	9.8	10	62.5	0.2	2
K69-063/4	63	57	9.8	10	62.5	0.2	2
K69-063/5	63	58	5.4	5.6	62.5	0.2	2
K69-063/2	63	58	9.5	9.7	62.5	0.2	2
K69-063/3	63	59	9.5	9.7	62.5	0.2	2
K69-065	65	60	15	15.2	64.5	0.2	2
K69-065/1	65	59	12.5	12.7	64.5	0.2	2
K69-065/2	65	60	9.5	9.7	64.5	0.2	2
K69-065/4	65	60	5.3	5.5	64.5	0.2	2
K69-065/5	65	60	8	8.2	64.5	0.2	2
K69-068	68	63	9.5	9.7	67.5	0.2	2
K69-070	70	65	15	15.2	69.5	0.2	2.5
K69-070/1	70	64	12.5	12.7	69.5	0.2	2.5
K69-070/2	70	65	9.5	9.7	69.5	0.2	2.5
K69-070/4	70	65	5.4	5.6	69.5	0.2	2.5
K69-070/3	70	66	9.8	10	69.5	0.2	2.5
K69-075	75	70	15	15.2	74.5	0.2	2.5
K69-075/1	75	69	12.5	12.7	74.5	0.2	2.5
K69-075/2	75	70	9.5	9.7	74.5	0.2	2.5
K69-075/3	75	70	5.4	5.6	74.5	0.2	2.5
K69-076.20	76.2	69.85	19.05	19.25	75.7	0.2	2.5
K69-080	80	75	15	15.2	79.5	0.2	2.5
K69-080/1	80	74	12.5	12.7	79.5	0.2	2.5
K69-080/2	80	75	8	8.2	79.5	0.2	2.5
K69-080/3	80	75	9.5	9.7	79.5	0.2	2.5
K69-080/5	80	72	6	6.2	79.5	0.2	2.5
K69-080/6	80	75	5.4	5.6	79.5	0.2	2.5
K69-080/4	80	76	15	15.2	79.5	0.2	2.5
K69-085	85	80	15	15.2	84.5	0.2	2.5
K69-085/1	85	79	12.5	12.7	84.5	0.2	2.5
K69-085/2	85	80	9.5	9.7	84.5	0.2	2.5
K69-085/3	85	80	19.8	20	84.5	0.2	2.5
K69-090	90	85	15	15.2	89.5	0.2	2.5
K69-090/1	90	84	12.5	12.7	89.5	0.2	2.5
K69-090/2	90	85	5.7	5.9	89.5	0.2	2.5
K69-090/3	90	85	9.7	9.9	89.5	0.2	2.5
K69-095	95	90	15	15.2	94.5	0.2	2.5
K69-095/1	95	89	12.5	12.7	94.5	0.2	2.5
K69-095/2	95	90	9.5	9.7	94.5	0.2	2.5

KASTAŞ NO	D (H8)	d (h8)	b	B (-0/+0.2)	d1 (h9)	r	k
K69-100	100	95	15	15.2	99.5	0.2	3.5
K69-100/1	100	94	12.5	12.7	99.5	0.2	3.5
K69-100/2	100	95	5.4	5.6	99.5	0.2	3.5
K69-100/4	100	94	12.8	13	99.5	0.2	3.5
K69-100/5	100	95	9.5	9.7	99.5	0.2	3.5
K69-100/3	100	96	10	10.2	99.5	0.2	3.5
K69-105	105	100	15	15.2	104.4	0.2	3.5
K69-105/2	105	100	9.7	9.9	104.4	0.2	3.5
K69-105/1	105	101	15	15.2	104.4	0.2	3.5
K69-110	110	104	12.5	12.7	109.4	0.2	3.5
K69-110/2	110	106	14.7	14.9	109.4	0.2	3.5
K69-110/1	110	105	9.5	9.7	109.4	0.2	3.5
K69-110/3	110	104	10	10.2	109.4	0.2	3.5
K69-115	115	109	12.5	12.7	114.4	0.2	3.5
K69-115/1	115	110	9.5	9.7	114.4	0.2	3.5
K69-120	120	114	12.5	12.7	119.4	0.2	3.5
K69-120/1	120	115	15	15.2	119.4	0.2	3.5
K69-120/2	120	115	9.5	9.7	119.4	0.2	3.5
K69-125	125	120	15	15.2	124.4	0.2	3.5
K69-125/1	125	19	12.5	12.7	124.4	0.2	3.5
K69-125/2	125	120	9.5	9.7	124.4	0.2	3.5
K69-125/4	125	119	15	15.2	124.4	0.2	3.5
K69-130	130	124	12.5	12.7	129.4	0.2	3.5
K69-130/1	130	125	15	15.2	129.4	0.2	3.5
K69-135	135	130	15	15.2	134.4	0.2	3.5
K69-140	140	134	12.5	12.7	139.4	0.2	3.5
K69-140/1	140	135	9.5	9.7	139.4	0.2	3.5
K69-140/2	140	135	15	15.2	139.4	0.2	3.5
K69-145	145	140	15	15.2	144.4	0.2	3.5
K69-150	150	144	12.5	12.7	149.4	0.2	3.5
K69-150/1	150	144	19	19.2	149.4	0.2	3.5
K69-150/2	150	145	9.5	9.7	149.4	0.2	3.5
K69-150/3	150	146	10	10.2	149.4	0.2	3.5
K69-160	160	155	15	15.2	159.4	0.2	3.5
K69-160/1	160	154	19	19.2	159.4	0.2	3.5
K69-160/2	160	155	9.5	9.7	159.4	0.2	3.5
K69-165	165	160	15	15.2	164.4	0.2	3.5
K69-170	170	165	15	15.2	169.4	0.2	3.5
K69-175	175	170	15	15.2	174.4	0.2	3.5
K69-180	180	174	19	19.2	179.4	0.2	3.5
K69-180/1	180	175	9.5	9.7	179.4	0.2	3.5
K69-185	185	180	15	15.2	184.4	0.2	3.5
K69-190	190	185	15	15.2	189.4	0.2	3.5
K69-195	195	190	15	15.2	194.4	0.2	3.5
K69-200	200	194	19	19.2	199.4	0.2	3.5
K69-200/1	200	195	15	15.2	199.4	0.2	3.5
K69-210	210	205	9.7	9.9	209.4	0.2	3.5
K69-220	220	214	19	19.2	219.4	0.2	3.5
K69-225	225	219	19	19.2	224.4	0.2	3.5
K69-250	250	244	19	19.2	249.4	0.2	3.5



K73 is a piston - rod guide ring designed to be used in heavy duty hydraulic and pneumatic systems.

PRODUCT ADVANTAGES

- High load bearing capacity
- Minimum static and dynamic friction coefficient for a minimum energy loss and operating temperature
- Able to be used behind the sealing element on dry condition
- High dimension stability during the operating temperatures
- Easy assembly
- Wide range of dimensions

APPLICATION

Mobile hydraulics, excavators, mining equipment, marine hydraulics, presses and heavy duty cylinders.

MATERIAL	CODE
POLYESTER RESIN	PR6501

OPERATING CONDITIONS			
MEDIA	Mineral oils (DIN 51524)	HFA and HFB	HFC
TEMPERATURE	-40°C +120°C	+5°C +60°C	-40°C +40°C
DYNAMIC CONTACT			
PRESSURE	≤100 N/mm ²	≤100 N/mm ²	≤100 N/mm ²
SPEED	≤1.0 m/sec	≤1.0 m/sec	≤1.0 m/sec

Note: The above data are maximum values and cannot be used at the same time. Surface contact pressure value is given for dynamic application and it is 330 N/mm² for static applications.

SURFACE ROUGHNESS		Ra	Rmax
Sliding Surface	∅D-∅d	≤0.4 μm	≤3.2 μm
Groove Base	∅Db-∅dp	≤1.6 μm	≤10 μm
Groove Flanks	B	≤3.2 μm	≤16 μm

INSTALLATION

Easily assembled into the housing by hand. It is very important that the assembly tools must be of soft material and have no sharp edges. Before installation, the guide ring must be oiled with system oil.

NOTES

To avoid hydrodynamic pressure, k interval is given.

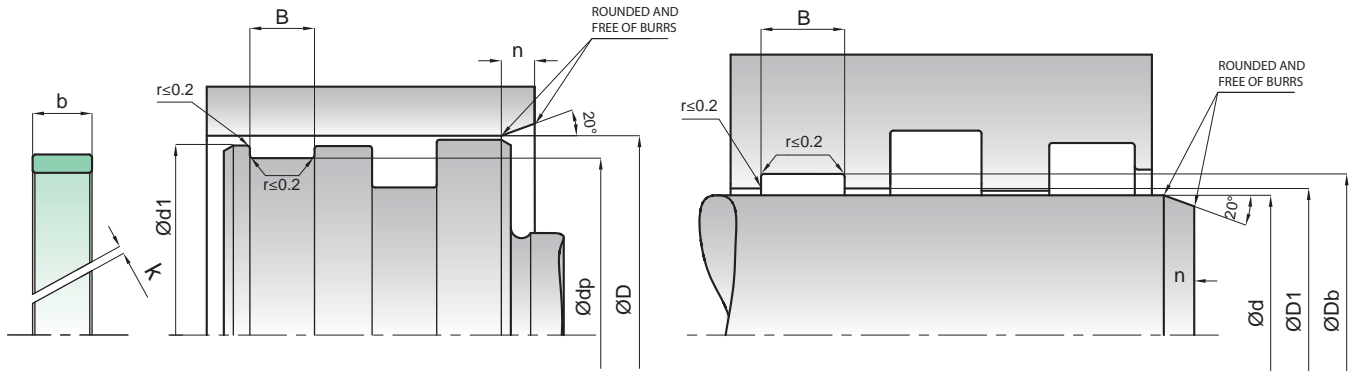

KASTAŞ NO	d(f8)/dp(h8)	Db(H8)/D(H9)	B(-0/+0.2)	b	d1 (h9)	D1 (H9)	k
K73-021	21	25	9.5	9.3	24	22	1
K73-030	30	35	9.7	9.5	33.2	31.8	1
K73-035	35	40	15	14.8	38.2	36.8	1
K73-040/3	40	43	5.6	5.4	42	41	1.5
K73-040/1	40	45	9.7	9.5	43.2	41.8	1.5
K73-040/2	40	45	15	14.8	43.2	41.8	1.5
K73-045	45	50	9.7	9.5	48.2	46.8	1.5
K73-045/1	45	50	15	14.8	48.2	46.8	1.5
K73-050/2	50	54	10	9.8	53	51	2
K73-050/3	50	55	5.6	5.4	53.2	51.8	2
K73-050	50	55	9.7	9.5	53.2	51.8	2
K73-050/1	50	55	15	14.8	53.2	51.8	2
K73-055/1	55	60	9.7	9.5	58.2	56.8	2
K73-055	55	60	15	14.8	58.2	56.8	2
K73-058	58	63	9.7	9.5	61.2	59.8	2
K73-058/1	58	63	5.6	5.4	61.2	59.8	2
K73-060/1	60	65	9.7	9.5	63.2	61.8	2.5
K73-060	60	65	15	14.8	63.2	61.8	2.5
K73-060/2	60	65	20	19.8	63.2	61.8	2.5
K73-065/2	65	70	5.6	5.4	68.2	66.8	2.5
K73-065/1	65	70	9.7	9.5	68.2	66.8	2.5
K73-065	65	70	15	14.8	68.2	66.8	2.5
K73-070	70	75	9.7	9.5	73.2	71.8	2.5
K73-070/1	70	75	15	14.8	73.2	71.8	2.5
K73-074	74	80	6.5	6.3	77.6	76.4	2.5
K73-075/2	75	80	5.6	5.4	78.2	76.8	2.5
K73-075	75	80	9.7	9.5	78.2	76.8	2.5
K73-075/1	75	80	15	14.8	78.2	76.8	2.5
K73-080	80	85	9.7	9.5	83.2	81.8	2.5
K73-080/1	80	85	15	14.8	83.2	81.8	2.5
K73-084	84	90	6.5	6.3	87.6	86.4	2.5
K73-085/2	85	90	5.6	5.4	88.2	86.8	2.5
K73-085	85	90	9.7	9.5	88.2	86.8	2.5
K73-085/1	85	90	15	14.8	88.2	86.8	2.5
K73-090/1	90	95	9.7	9.5	93.2	91.8	2.5
K73-090	90	95	15	14.8	93.2	91.8	2.5
K73-094	94	100	6.5	6.3	97.6	96.4	2.5
K73-095/2	95	100	5.6	5.4	98.2	96.8	2.5
K73-095	95	100	9.7	9.5	98.2	96.8	2.5
K73-095/1	95	100	15	14.8	98.2	96.8	2.5
K73-100/1	100	105	9.7	9.5	103.2	101.8	3.5
K73-100	100	105	15	14.8	103.2	101.8	3.5
K73-105/2	105	110	5.6	5.4	108.2	106.8	3.5
K73-105	105	110	9.7	9.5	108.2	106.8	3.5
K73-105/1	105	110	15	14.8	108.2	106.8	3.5
K73-109	109	115	6.5	6.3	112.6	111.4	3.5
K73-110	110	115	9.7	9.5	113.2	111.8	3.5
K73-110/1	110	115	15	14.8	113.2	111.8	3.5
K73-113	113	118	15	14.8	116.2	114.8	3.5

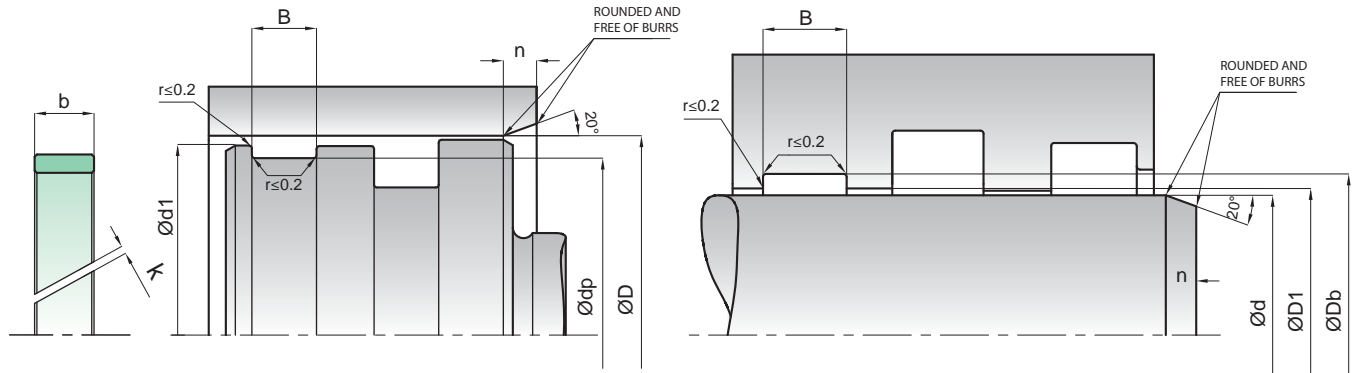

KASTAŞ NO	d(f8)/dp(h8)	Db(H8)/D(H9)	B(-0/+0.2)	b	d1 (h9)	D1 (H9)	k
K73-115	115	120	9.7	9.5	118.2	116.8	3.5
K73-115/1	115	120	15	14.8	118.2	116.8	3.5
K73-120	120	125	9.7	9.5	123.2	121.8	3.5
K73-120/1	120	125	15	14.8	123.2	121.8	3.5
K73-122	122	130	15	14.8	127	125	3.5
K73-125	125	130	9.7	9.5	128.2	126.8	3.5
K73-125/1	125	130	15	14.8	128.2	126.8	3.5
K73-125/2	125	133	9.7	9.5	130	128	3.5
K73-130	130	135	9.7	9.5	133.2	131.8	3.5
K73-130/1	130	135	15	14.8	133.2	131.8	3.5
K73-130/2	130	135	25	24.5	133.2	131.8	3.5
K73-135	135	140	9.7	9.5	138.2	136.8	3.5
K73-135/1	135	140	15	14.8	138.2	136.8	3.5
K73-140	140	145	9.7	9.5	143.2	141.8	3.5
K73-140/1	140	145	15	14.8	143.2	141.8	3.5
K73-140/2	140	148	15	14.8	145	143	3.5
K73-142	142	147	15	14.8	145.2	143.8	3.5
K73-145	145	150	9.7	9.5	148.2	146.8	3.5
K73-145/1	145	150	15	14.8	148.2	146.8	3.5
K73-150/1	150	155	9.7	9.5	153.2	151.8	3.5
K73-150	150	155	15	14.8	153.2	151.8	3.5
K73-155	155	160	9.7	9.5	158.2	156.8	3.5
K73-155/1	155	160	15	14.8	158.2	156.8	3.5
K73-160	160	168	25	24.5	165	163	3.5
K73-165	165	170	9.7	9.5	168.2	166.8	3.5
K73-175	175	180	9.7	9.5	178.2	176.8	3.5
K73-175/1	175	180	15	14.8	178.2	176.8	3.5
K73-180	180	185	15	14.8	183.2	181.8	3.5
K73-185	185	190	9.7	9.5	188.2	186.8	3.5
K73-185/1	185	190	15	14.8	188.2	186.8	3.5
K73-192/1	192	197	15	14.8	195.2	193.8	3.5
K73-195	195	200	9.7	9.5	198.2	196.8	3.5
K73-195/1	195	200	15	14.8	198.2	196.8	3.5
K73-200	200	205	15	14.8	203.2	201.8	4.5
K73-200/1	200	208	15	14.8	205	203	4.5
K73-205	205	210	15	14.8	208.2	206.8	4.5
K73-215	215	220	15	14.8	218.2	216.8	4.5
K73-225	225	230	15	14.8	228.2	226.8	4.5
K73-235	235	240	9.7	9.5	238.2	236.8	4.5
K73-240	240	245	15	14.8	243.2	241.8	4.5
K73-245	245	250	9.7	9.5	248.2	246.8	4.5
K73-245/1	245	250	15	14.8	248.2	246.8	4.5
K73-265	265	270	15	14.8	268.2	266.8	4.5
K73-275	275	280	9.7	9.5	278.2	276.8	4.5
K73-280	280	285	15	14.8	283.2	281.8	4.5
K73-285	285	290	25	24.5	288.2	286.8	4.5
K73-295	295	300	15	14.8	298.2	296.8	4.5
K73-315	315	320	15	14.8	318.2	316.8	4.5
K73-345	345	350	25	24.5	348.2	346.8	4.5



K74 is a guide ring designed to be used for rod applications.

PRODUCT ADVANTAGES

- Easy, snap-in fitting
- Medium load-bearing capacity
- Prevents hydrodynamic pressure due to the k interval
- Very good dimension stability during the operating temperatures
- Economical guiding solution

APPLICATION

Agricultural machinery, light to medium duty cylinders.

MATERIAL	CODE
POM special filled	PM9902

OPERATING CONDITIONS			
MEDIA	Mineral oils (DIN 51524)	HFA and HFB	HFC
TEMPERATURE	-30°C +125°C	+5°C +50°C	-30°C +40°C
CONTACT PRESSURE	≤40 N/mm ²	≤40 N/mm ²	≤40 N/mm ²
SPEED	≤1.0 m/sec	≤1.0 m/sec	≤1.0 m/sec

Note: The above data are maximum values and cannot be used at the same time.

SURFACE ROUGHNESS		Ra	Rmax
Sliding Surface	Ød	≤0.40 µm	≤3.2 µm
Groove Base	ØD	≤2.5 µm	≤10 µm
Groove Flanks	B	≤3.2 µm	≤16 µm

INSTALLATION

Easily assembled into the housing by hand. It is very important that the assembly tools must be of soft material and have no sharp edges. Before installation the guide element must be oiled with system oil.

NOTES

During design stage of the cylinder, K74 guide ring should be placed where it has direct contact with the media. K74 is not suitable for dry working conditions. Surface contact pressure value might drop due to the temperature increase.

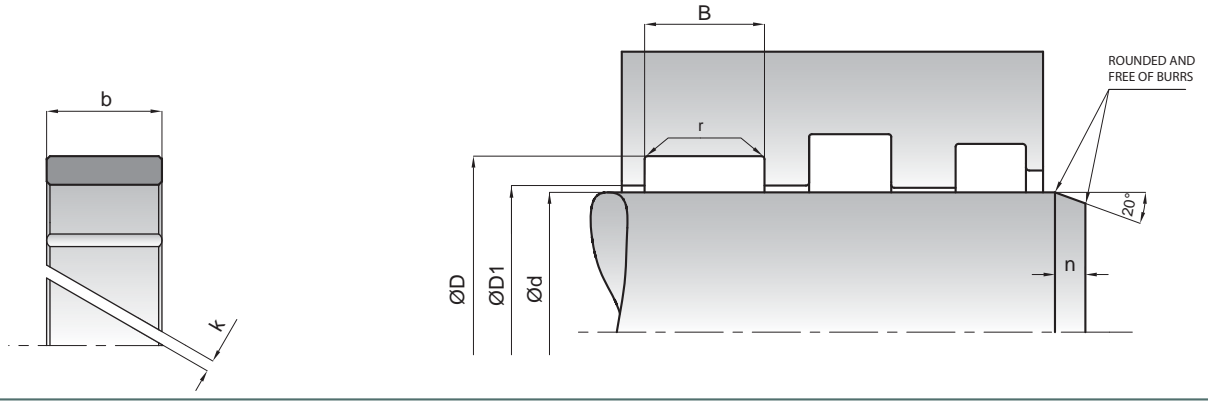

KASTAŞ NO	d (f8)	D (H8)	b	B (-0/+0.2)	D1 (H9)	r	k
K74-020	20	30	12.8	13	21	0.2	5
K74-025	25	35	12.8	13	26	0.2	5
K74-030	30	40	12.8	13	31	0.2	5
K74-035	35	45	12.8	13	36	0.2	5
K74-040	40	50	15.8	16	41	0.2	5
K74-045	45	55	15.8	16	46	0.2	5
K74-045/1	45	60	15.8	16	46	0.2	5
K74-055	55	65	15.8	16	56.5	0.2	5.5
K74-065	65	75	15.8	16	66.5	0.2	5.5
K74-075	75	85	15.8	16	76.5	0.2	5.5

Please contact our customer service for the dimensions out of our stock list.



KBT is a rod-piston guide strip designed to be used in medium duty hydraulic and pneumatic systems.

PRODUCT ADVANTAGES

- Easy assembly
- Medium load bearing capacity
- Able to work on dry conditions
- Easy to use in all dimensions because of being strips
- Low friction, free of stick-slip
- Superior load cushioning effect
- Able to absorb the small particles that is in the system

APPLICATION

Construction machinery, cranes, injection moulding machines, control and regulation equipment, chemical industry and standard cylinders.

MATERIAL	CODE
PTFE bronze filled	PT6003

OPERATING CONDITIONS		
MEDIA	Mineral oils (DIN 51524)	HFD
TEMPERATURE	-60°C +200°C	-40°C +200°C
CONTACT PRESSURE	≤15 N/mm ²	≤15 N/mm ²
SPEED	≤15.0 m/sec	≤15.0 m/sec

Note: The above data are maximum values and cannot be used at the same time.

SURFACE ROUGHNESS		Ra	Rmax
Sliding Surface	ØD-Ød	≤0.3 µm	≤2.5 µm
Groove Base	ØDb-Ødp	≤1.6 µm	≤10 µm
Groove Flanks	B	≤3.2 µm	≤12 µm

INSTALLATION

Easily assembled into the housing by hand. It is very important that the assembly tools must be of soft material and have no sharp edges. Before installation the guide strip must be oiled with system oil.

NOTES

We recommend cutting the ready strip with 30° angle before using it. The length of the strip can be calculated using the formula in the section; Calculation of Width & Cross Sectional Thickness of Guide Elements. The permissible sealing gap values of KBT guide strip is given in the below table.

PERMISSIBLE SEALING GAP	
Diameter (mm)	S(mm)
10-25	0.25±0.05
26-100	0.30±0.05
101-300	0.40±0.10
301-600	0.60±0.15
601-1200	0.80±0.20
>1200	0.90±0.30

Note: The largest sealing gap value occurring on the non-pressurized side of the seal is vital for the function of the seal and in this respect it is quite important to use the S value lower than the above indicated numbers.



KKT is a piston - rod guide strip designed to be used in light to medium duty hydraulic and pneumatic systems.

PRODUCT ADVANTAGES

- Easy assembly
- Medium load bearing capacity
- Easy to use in all dimensions because of being strips
- Low friction, free of stick-slip
- Superior load cushioning effect
- Able to work on dry conditions
- Able to absorb the small particles that is in the system

APPLICATION

Construction machinery, cranes, injection moulding machines, agricultural machinery, control and regulation equipment, chemical industry, standard cylinders and pneumatic cylinders.

MATERIAL	CODE
PTFE carbon filled	PT6002

OPERATING CONDITIONS	
MEDIA	Mineral oils (DIN 51524)
TEMPERATURE	-60°C +200°C
CONTACT PRESSURE	≤8 N/mm ²
SPEED	≤15.0 m/sec

Note: The above data are maximum values and cannot be used at the same time.

SURFACE ROUGHNESS		Ra	Rmax
Sliding Surface	∅D-∅d	≤0.3 μm	≤2.5 μm
Groove Base	∅Db-∅dp	≤1.6 μm	≤10 μm
Groove Flanks	B	≤3.2 μm	≤12 μm

INSTALLATION

Easily assembled into the housing by hand. It is very important that the assembly tools must be of soft material and have no sharp edges. Before installation the guide strip must be oiled with system oil.

NOTES

We recommend cutting the ready strip with 30° angle before using it. The length of the strip can be calculated using the formula in the section; Calculation of Width & Cross Sectional Thickness of Guide Elements. The permissible sealing gap values of KKT guide strip is given in the below table.

PERMISSIBLE SEALING GAP	
Diameter (mm)	S(mm)
10-25	0.25±0.05
26-100	0.30±0.05
101-300	0.40±0.10
301-600	0.60±0.15
601-1200	0.80±0.20
>1200	0.90±0.30

Note: The largest sealing gap value occurring on the non-pressurized side of the seal is vital for the function of the seal and in this respect it is quite important to use the S value lower than the above indicated numbers.

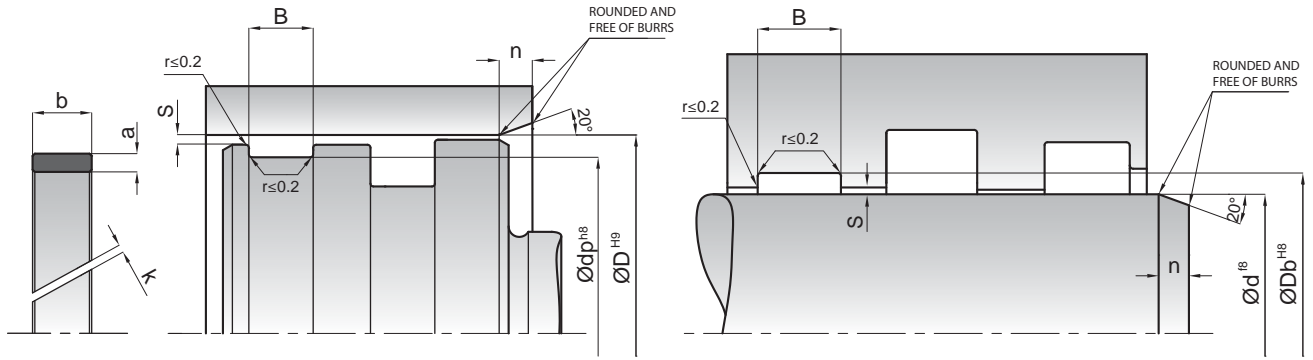

KASTAŞ NO	a	B (-0/+0.2)	b
KKT 2.5x9.7	2.5	9.7	9.5
KKT 2.5x15	2.5	15	14.8
KKT 2.5x20	2.5	20	19.8

Please contact our customer service for the dimensions out of our stock list.



KPB is a piston - rod guide strip designed to be used in heavy duty hydraulic and pneumatic systems.

PRODUCT ADVANTAGES

- High load bearing capacity
- Minimum static and dynamic friction coefficient for a minimum energy loss and operating temperature
- Can be used behind the sealing element on dry condition
- High dimension stability during the operating temperatures
- Easy assembly
- Wide range of dimensions
- Easy to use in all dimensions because of being strips

APPLICATION

Mobile hydraulics, excavators, mining equipment, marine hydraulics, presses and heavy duty cylinders.

MATERIAL	CODE
POLYESTER RESIN	PR6501

OPERATING CONDITIONS			
MEDIA	Mineral oils (DIN 51524)	HFA and HFB	HFC
TEMPERATURE	-40°C +120°C	+5°C +60°C	-40°C +40°C
DYNAMIC CONTACT PRESSURE	≤100 N/mm ²	≤100 N/mm ²	≤100 N/mm ²
SPEED	≤1.0 m/sec	≤1.0 m/sec	≤1.0 m/sec

Note: The above data are maximum values and cannot be used at the same time. Surface contact pressure value is given for dynamic application and it is 330 N/mm² for static applications.

SURFACE ROUGHNESS		Ra	Rmax
Sliding Surface	∅D-∅d	≤0.3 μm	≤2.5 μm
Groove Base	∅Db-∅dp	≤1.6 μm	≤10 μm
Groove Flanks	B	≤3.2 μm	≤12 μm

INSTALLATION

Easily assembled into the housing by hand. It is very important that the assembly tools must be of soft material and have no sharp edges. Before installation, the guide strip must be oiled with system oil.

NOTES

We recommend cutting the ready strip with 30° angle before using it. The length of the strip can be calculated using the formula in the section; Calculation of Width & Cross Sectional Thickness of Guide Elements. The permissible sealing gap values of KPB guide strip is given in the below table.

PERMISSIBLE SEALING GAP	
Cross-sectional thickness (mm)	S (mm)
2.00	0.60
2.50	0.75
3.00	0.90
4.00	1.20

Note: The largest sealing gap value occurring on the non-pressurized side of the seal is vital for the function of the seal and in this respect it is quite important to use the S value lower than the above indicated numbers.

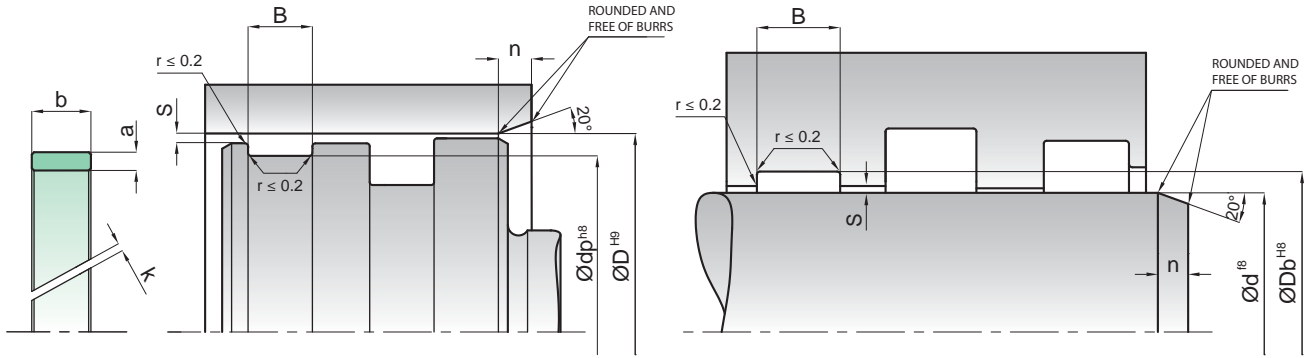

KASTAŞ NO	a	B (-0/+0.2)	b
KPB 2x10	2	10	9.8
KPB 2x15	2	15	14.8
KPB 2x20	2	20	19.8
KPB 2x25	2	25	24.5
KPB 2.5x5.6	2.5	5.6	5.4
KPB 2.5x9.7	2.5	9.7	9.5
KPB 2.5x10	2.5	10	9.8
KPB 2.5x15	2.5	15	14.8
KPB 2.5x20	2.5	20	19.8
KPB 2.5x25	2.5	25	24.5
KPB 3x15	3	15	14.8
KPB 3x20	3	20	19.8
KPB 3x25	3	25	24.5
KPB 4x9.7	4	9.7	9.5
KPB 4x15	4	15	14.8
KPB 4x20	4	20	19.8
KPB 4x25	4	25	24.5

Please contact our customer service for the dimensions out of our stock list.



Blank lined writing area consisting of 25 horizontal light gray lines.





STATIC SEALING ELEMENTS





Blank lined area for writing, consisting of 20 horizontal light gray lines.

STATIC SEALING ELEMENTS
SEAL PROGRAMME

KASTAŞ CODE	PRODUCT NAME	DRAWING	APPLICATION	MATERIAL	CODE	PRESSURE (max) bar	TEMPERATURE (max) °C	SLIDING SPEED (max) - m/sn	PAGE NO
K81	Back-up Ring		Piston Rod	TPE	TP5501	500	-40/+120	1.0	282
K82	Flange Seal			PU	PU9401	600	-30/+100		286
K83	Cover Seal			PU	PU9401	600	-30/+100		288
K84	Cover Seal			PU	PU9401	600	-30/+100		290
KO	O-Ring		Rod Piston	NBR	NB7001	63	-30/+105	0.5	294



K81 is a back-up ring designed to reduce the permissible sealing gap of the O-rings both for static and dynamic applications.

PRODUCT ADVANTAGES

- Able to work in high pressures
- Easy assembly
- Able to work in hard conditions
- Wide range of dimensions
- Used for rod and piston

APPLICATION

All types of hydraulic cylinders, injection moulding machines, mining equipment, marine hydraulics, loading platforms, cranes and heavy duty applications.

MATERIAL	CODE
TPE	TP5501

OPERATING CONDITIONS			
MEDIA	Mineral oils (DIN 51524)	HFA and HFB	HFC
TEMPERATURE	-40°C +120°C	+5°C +60°C	-30°C +60°C
PRESSURE	≤500 Bar	≤500 Bar	≤500 Bar
SPEED	≤1.0 m/sec	≤1.0 m/sec	≤1.0 m/sec

Note: The above data are maximum values and cannot be used at the same time.

SURFACE ROUGHNESS	Ra	Rmax
Sliding Surface	≤0.3 μm	≤3 μm
Groove Base	≤1.8 μm	≤10 μm
Groove Flanks	≤3 μm	≤16 μm

INSTALLATION

Easily assembled into the housing by hand. K81 back-up ring is in non split form. In case of a difficulty during installation the back-up ring can be cut carefully with 30° angle and assembled afterwards. It is very important that the assembly tools must be of soft material and have no sharp edges. Before installation the back-up ring must be oiled with system oil.

NOTES

K81 back-up ring is safely used with 0.20 mm permissible sealing gap up to 500 bar. For special applications PTFE back-up ring is produced on special requests.

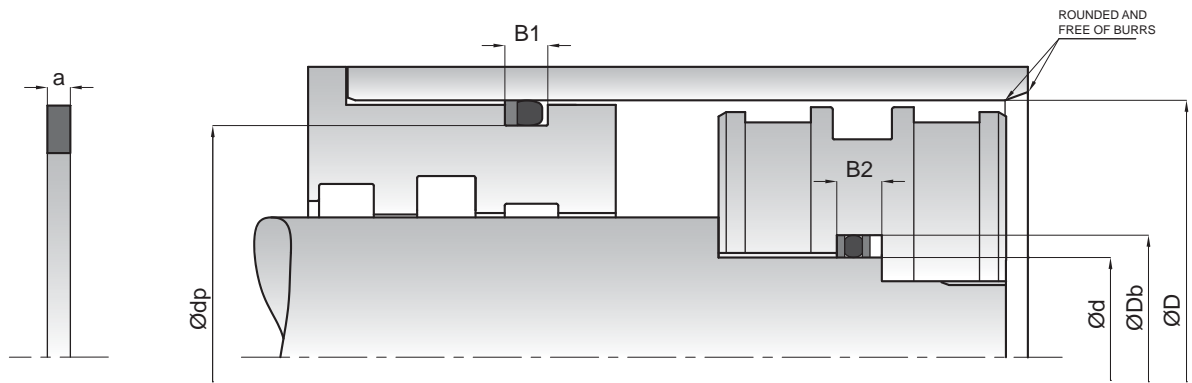

KASTAŞ NO	d (f7)/dp (h9)	Db (H9)/D (H8)	a	B1 (-0/+0.2)	B2 (-0/+0.2)	O-Ring d2
K81-014	14	18	1.3	4.7	6	2.62
K81-020	20	25	1.3	5.2	6.5	3
K81-025/1	25	30	1.3	5.2	6.5	3
K81-027	27	32	1.3	5.2	6.5	3
K81-035	35	40	1.3	5.2	6.5	3
K81-035/1	35.15	41	1.45	5.95	7.4	3.53
K81-036/1	36	40	1.8	5.2	7	2.62
K81-038	38	43	1.3	5.2	6.5	3
K81-040	40	45	1.3	5.2	6.5	3
K81-043	43	48	1.3	5.2	6.5	3
K81-045	45	50	1.3	5.2	6.5	3
K81-045/1	45.15	51	1.45	5.95	7.4	3.53
K81-049	49.3	55	1.3	5.8	7.1	3.53
K81-050	50	55	1.3	5.2	6.5	3
K81-050/2	50	60	1.7	9.1	10.8	5.7
K81-052	52	60	1.9	8.4	10.3	5
K81-053/1	53	63	1.7	9.1	10.8	5.7
K81-055	55	63	1.9	8.4	10.3	5
K81-055/2	55.15	61	1.45	5.95	7.4	3.53
K81-058	58	63	1.3	5.2	6.5	3
K81-060/1	60	70	1.7	9.1	10.8	5.7
K81-060/2	60	65	1.3	5.2	6.5	3
K81-062	62	70	1.9	8.4	10.3	5
K81-062/1	62.2	68	1.3	5.8	7.1	3.53
K81-062/2	62.15	71	1.7	8.6	10.3	5.33
K81-064	64	73.3	1.5	8.9	10.4	5.7
K81-065	65	70	1.3	5.2	6.5	3
K81-065/1	65	75	1.7	9.1	10.8	5.7
K81-070	70	75	1.3	5.2	6.5	3
K81-070/1	70	80	1.7	9.1	10.8	5.7
K81-072	72	80	1.9	8.4	10.3	5
K81-072/1	72.15	81	1.7	8.6	10.3	5.33
K81-075	75	80	1.3	5.2	6.5	3
K81-075/3	75	85	1.9	9.3	11.2	5.7
K81-079	79.8	89.1	1.5	8.9	10.4	5.7
K81-080	80	85	1.3	5.2	6.5	3
K81-082	82	90	1.9	8.4	10.3	5
K81-082/1	82.15	91	1.7	8.6	10.3	5.33
K81-084	84.3	90	1.3	5.8	7.1	3.53
K81-085	85	90	1.3	5.2	6.5	3
K81-090	90	95	1.3	5.2	6.5	3
K81-090/1	90	100	1.7	9.1	10.8	5.7
K81-092	92	100	1.9	8.4	10.3	5
K81-100	100	110	1.7	9.1	10.8	5.7
K81-100/1	100	108.2	1.9	8.4	10.3	5
K81-100/2	100.6	110	1.7	9.1	10.8	5.7
K81-102	102	110	1.9	8.4	10.3	5
K81-105	105	110	1.3	5.2	6.5	3
K81-107	107	115	1.9	8.4	10.3	5

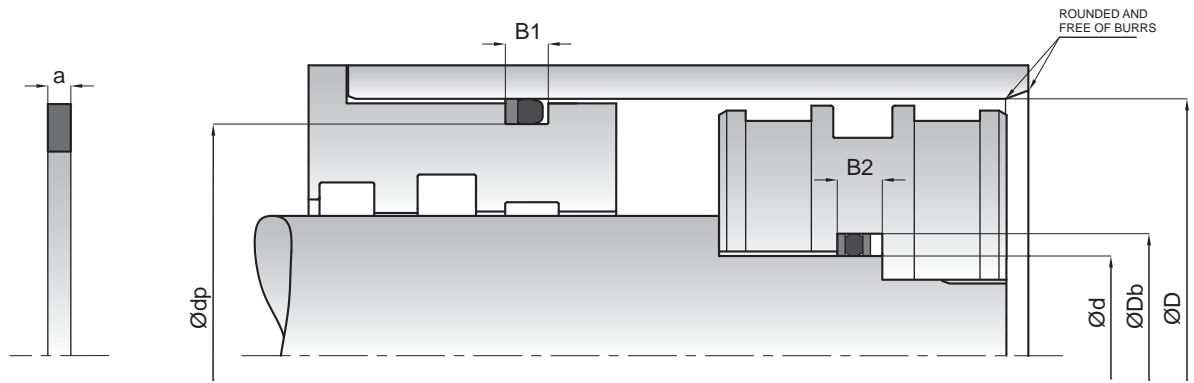

KASTAŞ NO	d (f7)/dp (h9)	Db (H9)/D (H8)	a	B1 (-0/+0.2)	B2 (-0/+0.2)	O-Ring d2
K81-109	109	118.3	1.9	9.27	11.14	5.7
K81-110	110	115	1.3	5.2	6.5	3
K81-110/1	110	120	1.7	9.1	10.8	5.7
K81-110/2	110	120	1.9	9.3	11.2	5.7
K81-112	112	120	1.9	8.4	10.3	5
K81-115	115	125	1.7	9.1	10.8	5.7
K81-115/1	115	124.3	1.5	8.9	10.4	5.7
K81-115/2	115	125	1.9	9.3	11.2	5.7
K81-117	117	125	1.9	8.4	10.3	5
K81-118	118.2	127.5	1.5	8.9	10.4	5.7
K81-120	120	125	1.3	5.2	6.5	3
K81-120/1	120	130	1.7	9.1	10.8	5.7
K81-122	122	130	1.9	8.4	10.3	5
K81-125	125	135	1.9	9.3	11.2	5.7
K81-130	130	140	1.7	9.1	10.8	5.7
K81-130/1	130.7	140	1.9	9.3	11.2	5.7
K81-138	138.4	150	2.5	11.6	14.1	6.99
K81-140	140	150	1.7	9.1	10.8	5.7
K81-145	145	160	2.1	13	15.1	8.4
K81-150	150.7	160	1.9	9.3	11.2	5.7
K81-150/1	150	160	1.7	9.1	10.8	5.7
K81-151	151	160	1.9	8.8	10.7	5.33
K81-153	153.3	165	2	11.1	13.1	6.99
K81-155	155	170	2.1	13	15.1	8.4
K81-155/1	155	165	1.7	9.1	10.8	5.7
K81-155/2	155	165	1.9	9.3	11.2	5.7
K81-158	158.4	170	2.5	11.6	14.1	6.99
K81-161	161.8	170	1.9	8.4	10.3	5
K81-165	165	180	2.1	13	15.1	8.4
K81-170	170.7	180	1.9	9.3	11.2	5.7
K81-175	175	190	2.1	13	15.1	8.4
K81-181	181.8	190	1.9	8.4	10.3	5
K81-185	185	200	2.1	13	15.1	8.4
K81-188	188.4	200	2.5	11.6	14.1	6.99
K81-190	190.7	200	1.9	9.3	11.2	5.7
K81-192	192.6	202	1.9	9.3	11.2	5.7
K81-198	198.4	210	2.5	11.6	14.1	6.99
K81-201	201.8	210	1.9	8.4	10.3	5
K81-205	205.7	215	1.9	9.3	11.2	5.7
K81-210	210.7	220	1.9	9.3	11.2	5.7
K81-216	216.6	225.8	1.9	8.8	10.7	5.33
K81-220	220.7	230	1.9	9.3	11.2	5.7
K81-220/1	220.3	232	2	11.1	13.1	6.99
K81-225	225	240	2.1	13	15.1	8.4
K81-228	228.4	240	2.5	11.6	14.1	6.99
K81-235	235	250	2.1	13	15.1	8.4
K81-240	240.7	250	1.9	9.3	11.2	5.7
K81-241	241.8	250	1.9	8.4	10.3	5
K81-245	245	260	2.1	13	15.1	8.4



K82 is a flange seal profile specially designed for static sealing of SAE flanges.

PRODUCT ADVANTAGES

- Able to work in high pressures
- Interchangeable for o-ring
- Functions even with poor surfaces
- Easy and secure installation
- High wear resistant
- High reliability

APPLICATION

Used in SAE type of flanges and valve blocks.

MATERIAL		CODE
PU	94 SHORE A	PU9401

OPERATING CONDITIONS			
MEDIA	Mineral oils (DIN 51524)	HFA and HFB	HFC
TEMPERATURE	-30°C +100°C	+5°C +50°C	-30°C +40°C
PRESSURE	≤600 Bar	≤600 Bar	≤600 Bar

Note: The above data are maximum values and cannot be used at the same time.

SURFACE ROUGHNESS	Ra	Rmax
Sliding Surface	≤0.4 μm	≤6.3 μm
Groove Surface	≤3.0 μm	≤25 μm

INSTALLATION

Easy installation by hand. The surface of the flanges should be dried prior to installation. It is very important that the assembly tools must be of soft material and have no sharp edges. Before installation the sealing element must be oiled with system oil.



K83 is a double acting cover seal specially designed for static applications.

PRODUCT ADVANTAGES

- High operating pressures
- High reliability
- Interchangeable for O-ring and O-ring with back-up ring
- Easy and secure installation
- No need for additional back-up ring
- High wear resistant

APPLICATION

All the hydraulic applications that O-rings are being used.

MATERIAL		CODE
PU	94 SHORE A	PU9401

OPERATING CONDITIONS			
MEDIA	Mineral oils (DIN 51524)	HFA and HFB	HFC
TEMPERATURE	-30°C +100°C	+5°C +50°C	-30°C +40°C
PRESSURE	≤600 Bar	≤600 Bar	≤600 Bar

Note: The above data are maximum values and cannot be used at the same time.

SURFACE ROUGHNESS		Ra	Rmax
Sliding Surface	Ød	≤0.8 µm	≤3.2 µm
Groove Base	ØD	≤1.6 µm	≤6.3 µm
Groove Flanks	B	≤6.3 µm	≤16 µm

INSTALLATION

Easy installation by hand. It is very important that the assembly tools must be of soft material and have no sharp edges. Before installation the sealing element must be oiled with system oil.

NOTES

K83 is a double acting cover seal for inner sealing. The difficulties faced during an O-ring assembly such as twisting, ripping was solved with this design. It can be used without a back-up ring at high pressures. When material is concerned, K83 has good wear resistance to extrusion and shows good sealing performance in double acting applications.

K83 COVER SEAL

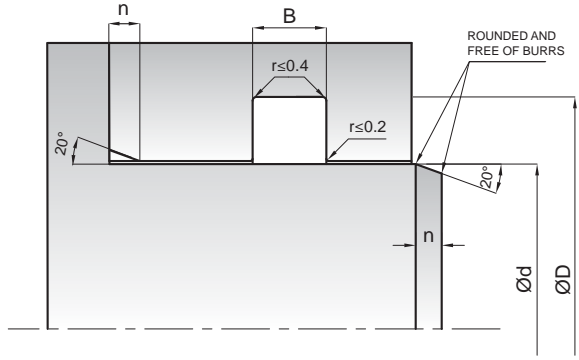
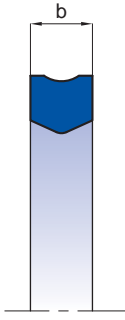

KASTAŞ NO	d (f7)	D (H8)	B (-0/+0.25)	b	n
K83-020	20	24	4.8	4.1	2
K83-025	25	29.2	5	4.1	2
K83-030	30	34	4.8	4.1	2
K83-035	35	39.5	4.5	3.8	2.5
K83-040	40	46	3	2.4	3
K83-050	50	58	6.4	5.6	4
K83-055	55	60.4	6.2	5.3	3
K83-060	60	65.5	5.2	4.5	3
K83-070	70	75.6	6.2	5.3	3
K83-080	80	90	10.5	9.2	4.5
K83-090	90	110	12.3	10.8	6
K83-105	105	112.8	5.8	5	4
K83-110	110	117	4.7	4	3.5
K83-120	120	140	12.3	10.8	6



K84 is a double acting cover seal specially designed for static applications.

PRODUCT ADVANTAGES

- High operating pressures
- High reliability
- Interchangeable for O-ring and O-ring with back-up ring
- Easy and secure installation
- No need for additional back-up ring
- High wear resistance

APPLICATION

All the hydraulic applications that O-rings are being used.

MATERIAL		CODE
PU	94 SHORE A	PU9401

OPERATING CONDITIONS			
MEDIA	Mineral oils (DIN 51524)	HFA and HFB	HFC
TEMPERATURE	-30°C +100°C	+5°C +50°C	-30°C +40°C
PRESSURE	≤600 Bar	≤600 Bar	≤600 Bar

Note: The above data are maximum values and cannot be used at the same time.

SURFACE ROUGHNESS		Ra	Rmax
Sliding Surface	∅D	≤0.8 μm	≤3.2 μm
Groove Base	∅d	≤1.6 μm	≤6.3 μm
Groove Flanks	B	≤6.3 μm	≤16 μm

INSTALLATION

Easy installation by hand. It is very important that the assembly tools must be of soft material and have no sharp edges. Before installation the sealing element must be oiled with system oil.

NOTES

K84 is a double acting cover seal for outer sealing. The difficulties faced during an O-ring assembly such as twisting, ripping was solved with this design. It can be used without a back-up ring at high pressures. When material is concerned, K84 has good wear resistance to extrusion and shows good sealing performance in double acting applications.

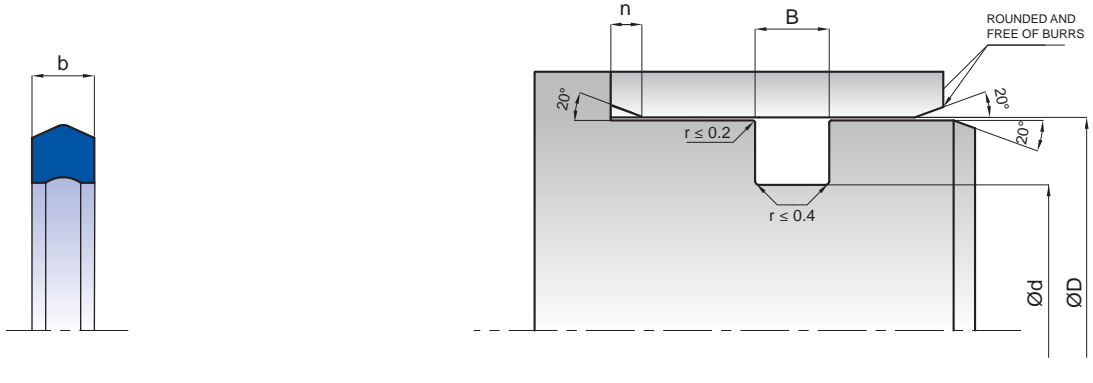

KASTAŞ NO	D (H8)	d (h8)	B (-0/+0.25)	b	n
K84-040	40	33.5	4.8	4.3	3
K84-040/1	40	32.8	3.4	2.8	3.5
K84-050	50	44.4	6.2	5.3	3
K84-070	70	64.4	6.2	5.3	3
K84-075	75	69.6	6.5	5.5	3
K84-085	85	80.8	5	4.2	2
K84-090	90	80.1	7.8	6.7	4.5
K84-095	95.5	87.7	5.8	5	4
K84-095/1	95	86.4	9	7.8	4
K84-100	100	90	7.8	7.3	4.5
K84-100/1	100	91.4	9	7.8	4
K84-105	105	95.1	7.8	6.7	4.5
K84-110	110	101.4	9	7.8	4
K84-125	125	116.4	9	7.8	4
K84-140	140	134.1	5.9	4.9	3
K84-150	150	141.9	9.2	8	4
K84-180	180	170	8.4	7.3	4.5
K84-200	200	191.4	9	7.8	4



20 horizontal light gray lines for writing, evenly spaced and spanning the width of the page.

O-RINGS



CHARACTERISTICS

Since the O-rings are cheap and simple sealing elements they have a wide application area in hydraulic and pneumatic systems. In case of providing suitable working conditions and equipments, they can be used both in static and dynamic applications. Because they occupy less space and provide two sided sealing compared with other sealing elements, O-rings enable easy designs. Having good results from O-ring applications is up to suitable measurements, choosing correct material, and proper surface quality of metal parts.

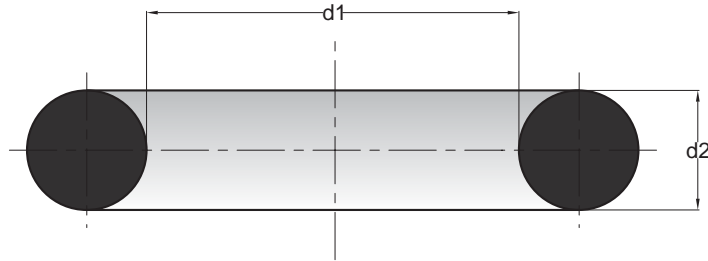

STATIC SEALING

If there is no permissible gap in static applications, for O-rings there is no certain pressure limit to resist against. But, it is required that tolerances should be chosen correctly and fixing screws should not create any gaps by extending in high pressures.

Static Pressure	Hardness
$P \leq 160$ Bar	70 Shore A
$P > 160$ Bar	90 Shore A

DYNAMIC SEALING

They are used in low dynamic pressures and similar others like pneumatic cylinders or valve spool.

Dynamic Pressure	Hardness
$P \leq 63$ Bar	70 Shore A
$P > 63$ Bar	90 Shore A

SURFACE ROUGHNESS

The other two most important factors in dynamic and static sealings are housing and the surface quality worked on. For dynamic applications, a better surface quality is required compared with static ones.

Application	Surface	Rmax.
Dynamic	Piston	$\leq 4 \mu\text{m}$
	Rod	$\leq 2 \mu\text{m}$
	Groove base	$\leq 6 - 1.2 \mu\text{m}$
	Groove flanks	$\leq 25 \mu\text{m}$
Static	Sliding surface	$\leq 10 \mu\text{m}$
	Groove base	$\leq 25 \mu\text{m}$

RECOMMENDED CROSS SECTIONS IN DYNAMIC OPERATIONS

	d1	d2
	9	1.78
	8	19
	18	40
	37	130
	110	150
		5.33 and 5.70
		6.99

GENERAL DIAMETER AND CROSS SECTIONAL THICKNESS TOLERANCES ACCORDING TO DIN 3771 PART 1

d1		d2			d1		d2			d1		d2		
		1,8 ±0,08	2,65 ±0,09	3,55 ±0,10			2,65 ±0,09	3,55 ±0,10	5,3 ±0,13			3,55 ±0,10	5,3 ±0,13	7 ±0,15
Tolerance				Tolerance				Tolerance						
1,8	± 0,13	X			36,5	± 0,35	X	X		165	± 1,31	X	X	
2	± 0,13	X			37,5	± 0,36	X	X		170	± 1,34	X	X	
2,24	± 0,13	X			38,7	± 0,37	X	X		175	± 1,38	X	X	
2,5	± 0,13	X			40	± 0,38		X	X	180	± 1,41	X	X	
2,8	± 0,14	X			41,2	± 0,39		X	X	185	± 1,44	X	X	
3,15	± 0,14	X			42,5	± 0,4		X	X	190	± 1,48	X	X	
3,55	± 0,14	X			43,7	± 0,41		X	X	195	± 1,51	X	X	
3,75	± 0,14	X			45	± 0,42		X	X	200	± 1,55	X	X	
4	± 0,14	X			46,2	± 0,43		X	X	206	± 1,59		X	X
4,5	± 0,14	X			47,5	± 0,44		X	X	212	± 1,63		X	X
4,87	± 0,15	X			48,7	± 0,45		X	X	218	± 1,67		X	X
5	± 0,15	X			50	± 0,46		X	X	224	± 1,71		X	X
5,15	± 0,15	X			51,5	± 0,47		X	X	230	± 1,75		X	X
5,3	± 0,15	X			53	± 0,48		X	X	236	± 1,79		X	X
5,6	± 0,15	X			54,5	± 0,50		X	X	243	± 1,83		X	X
6	± 0,15	X			56	± 0,51		X	X	250	± 1,88		X	X
6,3	± 0,15	X			58	± 0,52		X	X	258	± 1,93		X	X
6,7	± 0,16	X			60	± 0,54		X	X	265	± 1,98		X	X
6,9	± 0,16	X			61,5	± 0,55		X	X	272	± 2,02		X	X
7,1	± 0,16	X			63	± 0,56		X	X	280	± 2,08		X	X
7,5	± 0,16	X			65	± 0,58		X	X	290	± 2,14		X	X
8	± 0,16	X			67	± 0,59		X	X	300	± 2,21		X	X
8,5	± 0,16	X			69	± 0,61		X	X	307	± 2,25		X	X
8,76	± 0,17	X			71	± 0,63		X	X	315	± 2,30		X	X
9	± 0,17	X			73	± 0,64		X	X	325	± 2,37		X	X
9,5	± 0,17	X			75	± 0,66		X	X	335	± 2,43		X	X
10	± 0,17	X			77,5	± 0,67		X	X	345	± 2,49		X	X
10,6	± 0,18	X			80	± 0,69		X	X	355	± 2,56		X	X
11,2	± 0,18	X			82,5	± 0,71		X	X	365	± 2,62		X	X
11,8	± 0,19	X			85	± 0,73		X	X	375	± 2,68		X	X
12,5	± 0,19	X			87,5	± 0,75		X	X	387	± 2,76		X	X
13,2	± 0,19	X			90	± 0,77		X	X	400	± 2,84		X	X
14	± 0,19	X	X		92,5	± 0,79		X	X	412	± 2,91			X
15	± 0,20	X	X		95	± 0,81		X	X	425	± 2,99			X
16	± 0,20	X	X		97,5	± 0,83		X	X	437	± 3,07			X
17	± 0,21	X	X		100	± 0,84		X	X	450	± 3,15			X
18	± 0,21		X	X	103	± 0,87		X	X	462	± 3,22			X
19	± 0,22		X	X	106	± 0,89		X	X	475	± 3,30			X
20	± 0,22		X	X	109	± 0,91		X	X	487	± 3,37			X
21,2	± 0,23		X	X	112	± 0,93		X	X	500	± 3,45			X
22,4	± 0,24		X	X	115	± 0,95		X	X	515	± 3,54			X
23,6	± 0,24		X	X	118	± 0,97		X	X	530	± 3,63			X
25	± 0,25		X	X	122	± 1,00		X	X	545	± 3,72			X
25,8	± 0,26		X	X	125	± 1,03		X	X	560	± 3,81			X
26,5	± 0,26		X	X	128	± 1,05		X	X	580	± 3,93			X
28	± 0,28		X	X	132	± 1,08		X	X	600	± 4,05			X
30	± 0,29		X	X	136	± 1,10		X	X	615	± 4,13			X
31,5	± 0,31		X	X	140	± 1,13		X	X	530	± 4,22			X
32,5	± 0,32		X	X	145	± 1,17		X	X	650	± 4,34			X
33,5	± 0,32		X	X	150	± 1,20		X	X	670	± 4,46			X
34,5	± 0,33		X	X	155	± 1,24		X	X					
35,5	± 0,34		X	X	160	± 1,27		X	X					

CHAMFERS OF THE ROD OR THE HOUSING

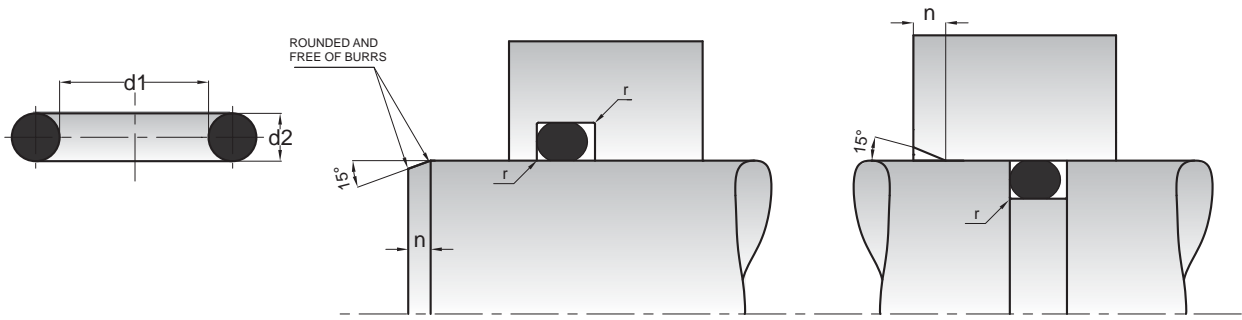

d2	n	d2	n
1.50	1.0	5.50	2.8
1.78	1.1	5.70	3.0
2.00	1.2	6.00	3.1
2.40	1.4	6.50	3.3
2.50	1.4	6.99	3.6
2.62	1.5	7.00	3.6
3.00	1.6	7.50	3.8
3.50	1.8	8.00	4.0
3.53	1.8	8.50	4.2
4.00	2.0	9.00	4.3
4.50	2.3	9.50	4.4
5.00	2.5	10.00	4.5
5.33	2.7		

TRIANGULAR GROOVES IN STATIC OPERATIONS

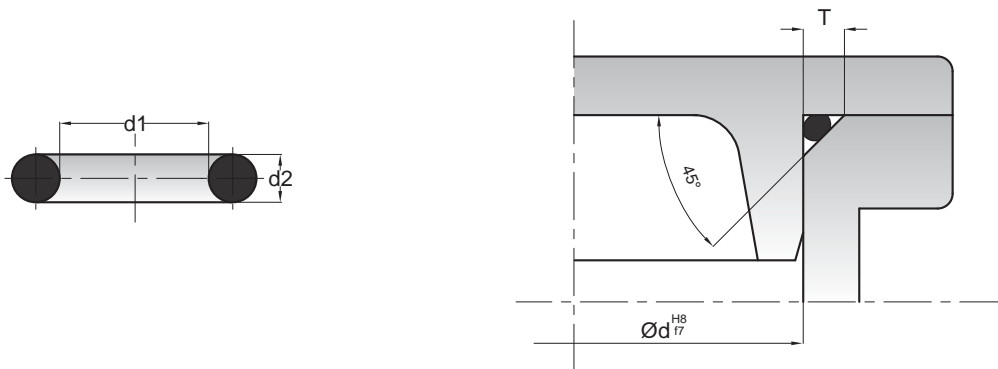

HOUSING VALUES

d2	T	d2	T
1.00	1.45 +0.08	4.50	6.15 +0.20
1.50	2.00 +0.08	5.00	6.85 +0.20
1.60	2.13 +0.08	5.33	7.35 +0.20
1.78	2.38 +0.08	5.70	7.85 +0.20
2.00	2.70 +0.08	6.00	8.25 +0.30
2.40	3.25 +0.12	6.50	8.95 +0.30
2.50	3.40 +0.12	6.99	9.60 +0.30
2.62	3.55 +0.12	8.00	11.00 +0.30
3.00	4.10 +0.20	8.40	11.55 +0.30
3.53	4.85 +0.20	9.00	12.40 +0.40
4.00	5.50 +0.20	10.00	13.70 +0.40

O-RING HOUSING VALUES IN PNEUMATIC SYSTEMS

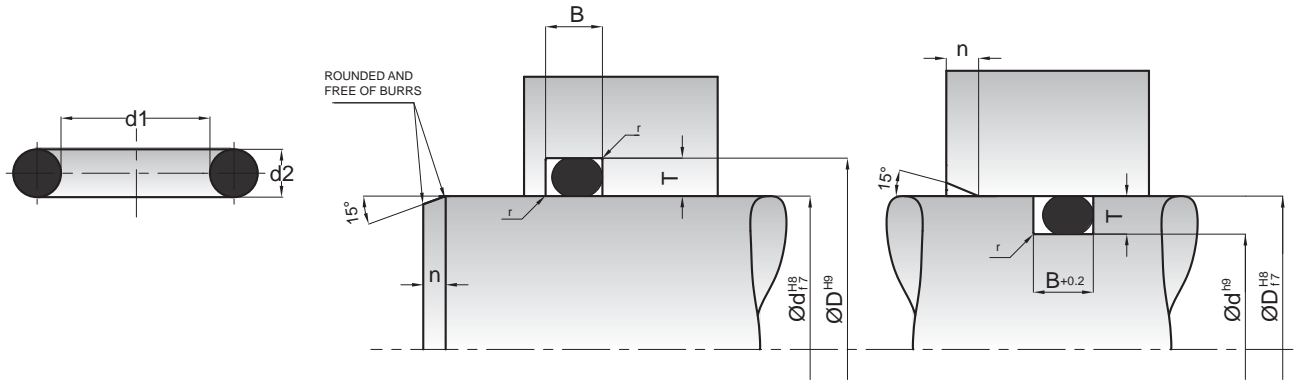

HOUSING VALUES

d2	T	B	n
1.50	1.35	1.9	1.0
1.78	1.55	2.3	1.1
2.00	1.80	2.4	1.2
2.40	2.15	2.9	1.4
2.50	2.25	3.0	1.4
2.62	2.35	3.1	1.5
3.00	2.75	3.6	1.6
3.53	3.25	4.2	1.8
4.00	3.70	4.8	2.0
5.00	4.65	6.0	2.5
5.33	4.95	6.4	2.7
5.70	5.35	6.9	3.0
6.00	5.65	7.2	3.1
6.99	6.60	8.4	3.6
8.00	7.60	9.6	4.0
9.00	8.50	10.8	4.3
10.00	9.50	12.0	4.5

O-RING HOUSING VALUES IN DYNAMIC OPERATIONS (AXIAL MOVEMENT)

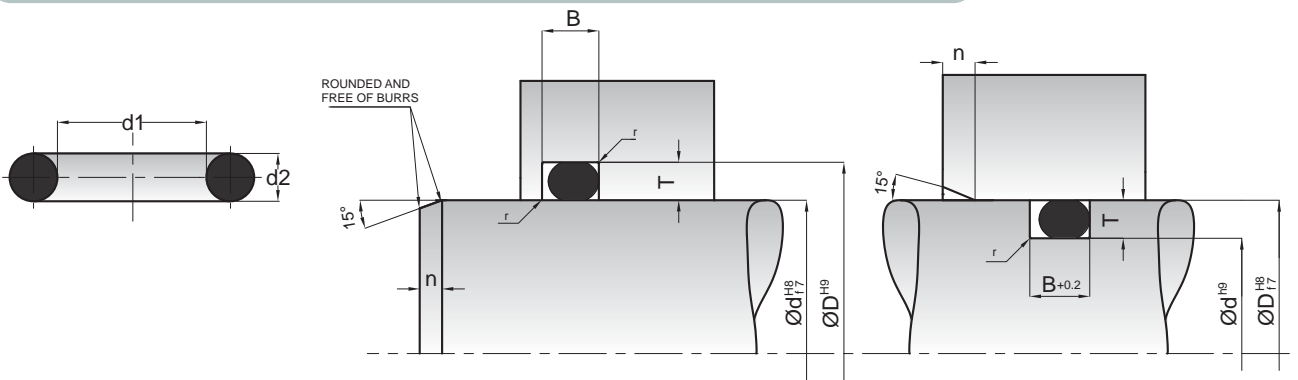

1.50	1.30	1.9	1.0
1.78	1.50	2.3	1.1
2.00	1.70	2.4	1.2
2.40	2.10	2.9	1.4
2.50	2.20	3.0	1.4
2.62	2.30	3.1	1.5
3.00	2.60	3.6	1.6
3.53	3.10	4.2	1.8
4.00	3.50	4.8	2.0
5.00	4.45	6.0	2.5
5.33	4.70	6.4	2.7
5.70	5.10	6.9	3.0
6.00	5.40	7.2	3.1
6.99	6.30	8.4	3.6
8.00	7.20	9.6	4.0
9.00	8.20	10.8	4.3
10.00	9.10	12.0	4.5

O-RINGS

KASTAŞ NO.	d1	d2	KASTAŞ NO.	d1	d2
KO-0018010 İ	1.80	1.00	KO-0271016 İ	27.10	1.60
KO-0020010 İ	2.00	1.00	KO-0017817 İ	1.78	1.78
KO-0025010 İ	2.50	1.00	KO-0025717 İ	2.57	1.78
KO-0030010 İ	3.00	1.00	KO-0029017 İ	2.90	1.78
KO-0040010 İ	4.00	1.00	KO-0031717 İ	3.17	1.78
KO-0050010 İ	5.00	1.00	KO-0036817 İ	3.68	1.78
KO-0060010 İ	6.00	1.00	KO-0044817 İ	4.48	1.78
KO-0070010 İ	7.00	1.00	KO-0047617 İ	4.76	1.78
KO-0080010 İ	8.00	1.00	KO-0052817 İ	5.28	1.78
KO-0090010 İ	9.00	1.00	KO-0060717 İ	6.07	1.78
KO-0100010 İ	10.00	1.00	KO-0063517 İ	6.35	1.78
KO-0110010 İ	11.00	1.00	KO-0067517 İ	6.75	1.78
KO-0120010 İ	12.00	1.00	KO-0076617 İ	7.66	1.78
KO-0130010 İ	13.00	1.00	KO-0087317 İ	8.73	1.78
KO-0135010 İ	13.50	1.00	KO-0092517 İ	9.25	1.78
KO-0140010 İ	14.00	1.00	KO-0096617 İ	9.66	1.78
KO-0150010 İ	15.00	1.00	KO-0097517 İ	9.75	1.78
KO-0160010 İ	16.00	1.00	KO-0108217 İ	10.82	1.78
KO-0200010 İ	20.00	1.00	KO-0111117 İ	11.11	1.78
KO-0320010 İ	32.00	1.00	KO-0124217 İ	12.42	1.78
KO-0030015 İ	3.00	1.50	KO-0140017 İ	14.00	1.78
KO-0035015 İ	3.50	1.50	KO-0152017 İ	15.20	1.78
KO-0040015 İ	4.00	1.50	KO-0156017 İ	15.60	1.78
KO-0045015 İ	4.50	1.50	KO-0171717 İ	17.17	1.78
KO-0050015 İ	5.00	1.50	KO-0187717 İ	18.77	1.78
KO-0060015 İ	6.00	1.50	KO-0203517 İ	20.35	1.78
KO-0070015 İ	7.00	1.50	KO-0219517 İ	21.95	1.78
KO-0075015 İ	7.50	1.50	KO-0235317 İ	23.53	1.78
KO-0080015 İ	8.00	1.50	KO-0251217 İ	25.12	1.78
KO-0090015 İ	9.00	1.50	KO-0267017 İ	26.70	1.78
KO-0095015 İ	9.50	1.50	KO-0283017 İ	28.30	1.78
KO-0100015 İ	10.00	1.50	KO-0298717 İ	29.87	1.78
KO-0110015 İ	11.00	1.50	KO-0314717 İ	31.47	1.78
KO-0120015 İ	12.00	1.50	KO-0330517 İ	33.05	1.78
KO-0130015 İ	13.00	1.50	KO-0346517 İ	34.65	1.78
KO-0140015 İ	14.00	1.50	KO-0362717 İ	36.27	1.78
KO-0150015 İ	15.00	1.50	KO-0378217 İ	37.82	1.78
KO-0160015 İ	16.00	1.50	KO-0394517 İ	39.45	1.78
KO-0170015 İ	17.00	1.50	KO-0410017 İ	41.00	1.78
KO-0180015 İ	18.00	1.50	KO-0441717 İ	44.17	1.78
KO-0190015 İ	19.00	1.50	KO-0473717 İ	47.37	1.78
KO-0200015 İ	20.00	1.50	KO-0505217 İ	50.52	1.78
KO-0210015 İ	21.00	1.50	KO-0536717 İ	53.67	1.78
KO-0220015 İ	22.00	1.50	KO-0568717 İ	56.87	1.78
KO-0240015 İ	24.00	1.50	KO-0632217 İ	63.22	1.78
KO-0250015 İ	25.00	1.50	KO-0664017 İ	66.40	1.78
KO-0260015 İ	26.00	1.50	KO-0695717 İ	69.57	1.78
KO-0280015 İ	28.00	1.50	KO-0727617 İ	72.76	1.78
KO-0350015 İ	35.00	1.50	KO-0759217 İ	75.92	1.78
KO-0400015 İ	40.00	1.50	KO-0790017 İ	79.00	1.78
KO-0500015 İ	50.00	1.50	KO-0030020 İ	3.00	2.00
KO-0630015 İ	63.00	1.50	KO-0040020 İ	4.00	2.00
KO-0041016 İ	4.10	1.60	KO-0050020 İ	5.00	2.00
KO-0051016 İ	5.10	1.60	KO-0055020 İ	5.50	2.00
KO-0071016 İ	7.10	1.60	KO-0060020 İ	6.00	2.00
KO-0091016 İ	9.10	1.60	KO-0065020 İ	6.50	2.00
KO-0101016 İ	10.10	1.60	KO-0070020 İ	7.00	2.00
KO-0111016 İ	11.10	1.60	KO-0080020 İ	8.00	2.00
KO-0131016 İ	13.10	1.60	KO-0090020 İ	9.00	2.00
KO-0141016 İ	14.10	1.60	KO-0100020 İ	10.00	2.00
KO-0181016 İ	18.10	1.60	KO-0110020 İ	11.00	2.00
KO-0191016 İ	19.10	1.60	KO-0120020 İ	12.00	2.00
			KO-0130020 İ	13.00	2.00

O-RINGS

KASTAŞ NO.	d1	d2	KASTAŞ NO.	d1	d2
KO-0140020 İ	14.00	2.00	KO-0116024 İ	11.60	2.40
KO-0150020 İ	15.00	2.00	KO-0123024 İ	12.30	2.40
KO-0160020 İ	16.00	2.00	KO-0133024 İ	13.30	2.40
KO-0170020 İ	17.00	2.00	KO-0136024 İ	13.60	2.40
KO-0180020 İ	18.00	2.00	KO-0143024 İ	14.30	2.40
KO-0190020 İ	19.00	2.00	KO-0146024 İ	14.60	2.40
KO-0200020 İ	20.00	2.00	KO-0153024 İ	15.30	2.40
KO-0205020 İ	20.50	2.00	KO-0163024 İ	16.30	2.40
KO-0210020 İ	21.00	2.00	KO-0173024 İ	17.30	2.40
KO-0220020 İ	22.00	2.00	KO-0183024 İ	18.30	2.40
KO-0230020 İ	23.00	2.00	KO-0193024 İ	19.30	2.40
KO-0240020 İ	24.00	2.00	KO-0203024 İ	20.30	2.40
KO-0250020 İ	25.00	2.00	KO-0216024 İ	21.60	2.40
KO-0260020 İ	26.00	2.00	KO-0223024 İ	22.30	2.40
KO-0270020 İ	27.00	2.00	KO-0233024 İ	23.30	2.40
KO-0280020 İ	28.00	2.00	KO-0246024 İ	24.60	2.40
KO-0290020 İ	29.00	2.00	KO-0253024 İ	25.30	2.40
KO-0300020 İ	30.00	2.00	KO-0273024 İ	27.30	2.40
KO-0310020 İ	31.00	2.00	KO-0275024 İ	27.50	2.40
KO-0320020 İ	32.00	2.00	KO-0296024 İ	29.60	2.40
KO-0330020 İ	33.00	2.00	KO-0303024 İ	30.30	2.40
KO-0340020 İ	34.00	2.00	KO-0333024 İ	33.30	2.40
KO-0350020 İ	35.00	2.00	KO-0376024 İ	37.60	2.40
KO-0360020 İ	36.00	2.00	KO-0040025 İ	4.00	2.50
KO-0370020 İ	37.00	2.00	KO-0050025 İ	5.00	2.50
KO-0380020 İ	38.00	2.00	KO-0070025 İ	7.00	2.50
KO-0390020 İ	39.00	2.00	KO-0080025 İ	8.00	2.50
KO-0400020 İ	40.00	2.00	KO-0090025 İ	9.00	2.50
KO-0420020 İ	42.00	2.00	KO-0100025 İ	10.00	2.50
KO-0430020 İ	43.00	2.00	KO-0110025 İ	11.00	2.50
KO-0450020 İ	45.00	2.00	KO-0120025 İ	12.00	2.50
KO-0460020 İ	46.00	2.00	KO-0130025 İ	13.00	2.50
KO-0470020 İ	47.00	2.00	KO-0140025 İ	14.00	2.50
KO-0480020 İ	48.00	2.00	KO-0150025 İ	15.00	2.50
KO-0500020 İ	50.00	2.00	KO-0160025 İ	16.00	2.50
KO-0530020 İ	53.00	2.00	KO-0170025 İ	17.00	2.50
KO-0550020 İ	55.00	2.00	KO-0175025 İ	17.50	2.50
KO-0560020 İ	56.00	2.00	KO-0180025 İ	18.00	2.50
KO-0570020 İ	57.00	2.00	KO-0190025 İ	19.00	2.50
KO-0580020 İ	58.00	2.00	KO-0200025 İ	20.00	2.50
KO-0600020 İ	60.00	2.00	KO-0210025 İ	21.00	2.50
KO-0620020 İ	62.00	2.00	KO-0230025 İ	23.00	2.50
KO-0630020 İ	63.00	2.00	KO-0240025 İ	24.00	2.50
KO-0650020 İ	65.00	2.00	KO-0250025 İ	25.00	2.50
KO-0700020 İ	70.00	2.00	KO-0260025 İ	26.00	2.50
KO-0750020 İ	75.00	2.00	KO-0270025 İ	27.00	2.50
KO-0760020 İ	76.00	2.00	KO-0280025 İ	28.00	2.50
KO-0800020 İ	80.00	2.00	KO-0285025 İ	28.00	2.50
KO-0850020 İ	85.00	2.00	KO-0290025 İ	29.00	2.50
KO-0870020 İ	87.00	2.00	KO-0300025 İ	30.00	2.50
KO-0900020 İ	90.00	2.00	KO-0320025 İ	32.00	2.50
KO-1000020 İ	100.00	2.00	KO-0330025 İ	33.00	2.50
KO-0033024 İ	3.30	2.40	KO-0340025 İ	34.00	2.50
KO-0036024 İ	3.60	2.40	KO-0350025 İ	35.00	2.50
KO-0043024 İ	4.30	2.40	KO-0360025 İ	36.00	2.50
KO-0053024 İ	5.30	2.40	KO-0370025 İ	37.00	2.50
KO-0063024 İ	6.30	2.40	KO-0390025 İ	39.00	2.50
KO-0073024 İ	7.30	2.40	KO-0400025 İ	40.00	2.50
KO-0093024 İ	9.30	2.40	KO-0430025 İ	43.00	2.50
KO-0096024 İ	9.60	2.40	KO-0440025 İ	44.00	2.50
KO-0103024 İ	10.30	2.40	KO-0450025 İ	45.00	2.50
KO-0106024 İ	10.60	2.40	KO-0500025 İ	50.00	2.50
KO-0113024 İ	11.30	2.40	KO-0550025 İ	55.00	2.50

O-RINGS

KASTAŞ NO.	d1	d2	KASTAŞ NO.	d1	d2
KO-0600025 İ	60.00	2.50	KO-0806026 İ	80.60	2.62
KO-0650025 İ	65.00	2.50	KO-0822226 İ	82.22	2.62
KO-0800025 İ	80.00	2.50	KO-0845226 İ	84.52	2.62
KO-0870025 İ	87.00	2.50	KO-0885726 İ	88.57	2.62
KO-0900025 İ	90.00	2.50	KO-0949326 İ	94.93	2.62
KO-0036326 İ	3.63	2.62	KO-1012726 İ	101.27	2.62
KO-0044226 İ	4.42	2.62	KO-1076326 İ	107.63	2.62
KO-0052326 İ	5.23	2.62	KO-1139826 İ	113.98	2.62
KO-0060226 İ	6.02	2.62	KO-1203226 İ	120.32	2.62
KO-0076026 İ	7.60	2.62	KO-1266726 İ	126.67	2.62
KO-0091926 İ	9.19	2.62	KO-1330226 İ	133.02	2.62
KO-0099226 İ	9.92	2.62	KO-0050030 İ	5.00	3.00
KO-0107826 İ	10.78	2.62	KO-0060030 İ	6.00	3.00
KO-0119126 İ	11.91	2.62	KO-0070030 İ	7.00	3.00
KO-0123726 İ	12.37	2.62	KO-0075030 İ	7.50	3.00
KO-0131026 İ	13.10	2.62	KO-0080030 İ	8.00	3.00
KO-0139526 İ	13.95	2.62	KO-0090030 İ	9.00	3.00
KO-0150826 İ	15.08	2.62	KO-0100030 İ	10.00	3.00
KO-0155426 İ	15.54	2.62	KO-0110030 İ	11.00	3.00
KO-0158826 İ	15.88	2.62	KO-0120030 İ	12.00	3.00
KO-0171326 İ	17.13	2.62	KO-0130030 İ	13.00	3.00
KO-0178626 İ	17.86	2.62	KO-0140030 İ	14.00	3.00
KO-0187226 İ	18.72	2.62	KO-0150030 İ	15.00	3.00
KO-0202926 İ	20.29	2.62	KO-0160030 İ	16.00	3.00
KO-0206326 İ	20.63	2.62	KO-0170030 İ	17.00	3.00
KO-0218926 İ	21.89	2.62	KO-0180030 İ	18.00	3.00
KO-0222226 İ	22.22	2.62	KO-0190030 İ	19.00	3.00
KO-0234726 İ	23.47	2.62	KO-0200030 İ	20.00	3.00
KO-0238126 İ	23.81	2.62	KO-0210030 İ	21.00	3.00
KO-0250726 İ	25.07	2.62	KO-0220030 İ	22.00	3.00
KO-0266426 İ	26.64	2.62	KO-0230030 İ	23.00	3.00
KO-0282526 İ	28.25	2.62	KO-0240030 İ	24.00	3.00
KO-0298226 İ	29.82	2.62	KO-0250030 İ	25.00	3.00
KO-0314226 İ	31.42	2.62	KO-0260030 İ	26.00	3.00
KO-0330026 İ	33.00	2.62	KO-0270030 İ	27.00	3.00
KO-0345926 İ	34.59	2.62	KO-0280030 İ	28.00	3.00
KO-0361726 İ	36.17	2.62	KO-0290030 İ	29.00	3.00
KO-0377726 İ	37.77	2.62	KO-0300030 İ	30.00	3.00
KO-0393426 İ	39.34	2.62	KO-0302030 İ	30.20	3.00
KO-0409526 İ	40.95	2.62	KO-0310030 İ	31.00	3.00
KO-0425226 İ	42.52	2.62	KO-0320030 İ	32.00	3.00
KO-0441226 İ	44.12	2.62	KO-0330030 İ	33.00	3.00
KO-0456926 İ	45.69	2.62	KO-0340030 İ	34.00	3.00
KO-0472926 İ	47.29	2.62	KO-0350030 İ	35.00	3.00
KO-0489026 İ	48.90	2.62	KO-0360030 İ	36.00	3.00
KO-0504726 İ	50.47	2.62	KO-0370030 İ	37.00	3.00
KO-0520726 İ	52.07	2.62	KO-0380030 İ	38.00	3.00
KO-0536526 İ	53.65	2.62	KO-0390030 İ	39.00	3.00
KO-0552526 İ	55.25	2.62	KO-0400030 İ	40.00	3.00
KO-0568226 İ	56.82	2.62	KO-0410030 İ	41.00	3.00
KO-0584226 İ	58.42	2.62	KO-0420030 İ	42.00	3.00
KO-0600026 İ	60.00	2.62	KO-0430030 İ	43.00	3.00
KO-0616026 İ	61.60	2.62	KO-0440030 İ	44.00	3.00
KO-0631726 İ	63.17	2.62	KO-0450030 İ	45.00	3.00
KO-0647726 İ	64.77	2.62	KO-0460030 İ	46.00	3.00
KO-0663526 İ	66.35	2.62	KO-0470030 İ	47.00	3.00
KO-0679526 İ	67.95	2.62	KO-0480030 İ	48.00	3.00
KO-0695226 İ	69.52	2.62	KO-0490030 İ	49.00	3.00
KO-0711226 İ	71.12	2.62	KO-0500030 İ	50.00	3.00
KO-0726926 İ	72.69	2.62	KO-0520030 İ	52.00	3.00
KO-0743026 İ	74.30	2.62	KO-0530030 İ	53.00	3.00
KO-0758726 İ	75.87	2.62	KO-0540030 İ	54.00	3.00
KO-0774726 İ	77.47	2.62	KO-0550030 İ	55.00	3.00

O-RINGS

KASTAŞ NO.	d1	d2	KASTAŞ NO.	d1	d2
KO-0560003 İ	56.00	3.00	KO-0258035 İ	25.80	3.53
KO-0570030 İ	57.00	3.00	KO-0265835 İ	26.58	3.53
KO-0580030 İ	58.00	3.00	KO-0281735 İ	28.17	3.53
KO-0590030 İ	59.00	3.00	KO-0297535 İ	29.75	3.53
KO-0600030 İ	60.00	3.00	KO-0313435 İ	31.34	3.53
KO-0620030 İ	62.00	3.00	KO-0329235 İ	32.92	3.53
KO-0630030 İ	63.00	3.00	KO-0345235 İ	34.52	3.53
KO-0640030 İ	64.00	3.00	KO-0361035 İ	36.10	3.53
KO-0650030 İ	65.00	3.00	KO-0376935 İ	37.69	3.53
KO-0660030 İ	66.00	3.00	KO-0396935 İ	39.69	3.53
KO-0680030 İ	68.00	3.00	KO-0408735 İ	40.87	3.53
KO-0690030 İ	69.00	3.00	KO-0412835 İ	41.28	3.53
KO-0700030 İ	70.00	3.00	KO-0428635 İ	42.86	3.53
KO-0720030 İ	72.00	3.00	KO-0440435 İ	44.04	3.53
KO-0730030 İ	73.00	3.00	KO-0444535 İ	44.45	3.53
KO-0740030 İ	74.00	3.00	KO-0460435 İ	46.04	3.53
KO-0750030 İ	75.00	3.00	KO-0472235 İ	47.22	3.53
KO-0760030 İ	76.00	3.00	KO-0476335 İ	47.63	3.53
KO-0770030 İ	77.00	3.00	KO-0492135 İ	49.21	3.53
KO-0780030 İ	78.00	3.00	KO-0504035 İ	50.40	3.53
KO-0790030 İ	79.00	3.00	KO-0508035 İ	50.80	3.53
KO-0800030 İ	80.00	3.00	KO-0523935 İ	52.39	3.53
KO-0820030 İ	82.00	3.00	KO-0535735 İ	53.57	3.53
KO-0830030 İ	83.00	3.00	KO-0555635 İ	55.56	3.53
KO-0840030 İ	84.00	3.00	KO-0567435 İ	56.74	3.53
KO-0850030 İ	85.00	3.00	KO-0571535 İ	57.15	3.53
KO-0880030 İ	88.00	3.00	KO-0587435 İ	58.74	3.53
KO-0900030 İ	90.00	3.00	KO-0599235 İ	59.92	3.53
KO-0920030 İ	92.00	3.00	KO-0603335 İ	60.33	3.53
KO-0940030 İ	94.00	3.00	KO-0619035 İ	61.90	3.53
KO-0950030 İ	95.00	3.00	KO-0630935 İ	63.09	3.53
KO-0960030 İ	96.00	3.00	KO-0635035 İ	63.50	3.53
KO-0980030 İ	98.00	3.00	KO-0651035 İ	65.10	3.53
KO-1000030 İ	100.00	3.00	KO-0662735 İ	66.27	3.53
KO-1045030 İ	104.50	3.00	KO-0666835 İ	66.68	3.53
KO-1080030 İ	108.00	3.00	KO-0682635 İ	68.26	3.53
KO-1100030 İ	110.00	3.00	KO-0694435 İ	69.44	3.53
KO-1120030 İ	112.00	3.00	KO-0698535 İ	69.85	3.53
KO-1150030 İ	115.00	3.00	KO-0714435 İ	71.44	3.53
KO-1180030 İ	118.00	3.00	KO-0726235 İ	72.62	3.53
KO-1200030 İ	120.00	3.00	KO-0730335 İ	73.03	3.53
KO-1250030 İ	125.00	3.00	KO-0746135 İ	74.61	3.53
KO-1300030 İ	130.00	3.00	KO-0758035 İ	75.80	3.53
KO-1350030 İ	135.00	3.00	KO-0789735 İ	78.97	3.53
KO-1400030 İ	140.00	3.00	KO-0821435 İ	82.14	3.53
KO-1450030 İ	145.00	3.00	KO-0853235 İ	85.32	3.53
KO-0043435 İ	4.34	3.53	KO-0885035 İ	88.50	3.53
KO-0059435 İ	5.94	3.53	KO-0916735 İ	91.67	3.53
KO-0075235 İ	7.52	3.53	KO-0948435 İ	94.84	3.53
KO-0091235 İ	9.12	3.53	KO-0980235 İ	98.02	3.53
KO-0097535 İ	9.75	3.53	KO-1012035 İ	101.20	3.53
KO-0106935 İ	10.69	3.53	KO-1043735 İ	104.37	3.53
KO-0118035 İ	11.80	3.53	KO-1075435 İ	107.54	3.53
KO-0122935 İ	12.29	3.53	KO-1107235 İ	110.72	3.53
KO-0130035 İ	13.00	3.53	KO-1139035 İ	113.90	3.53
KO-0138735 İ	13.87	3.53	KO-1170735 İ	117.07	3.53
KO-0154735 İ	15.47	3.53	KO-1202535 İ	120.25	3.53
KO-0170435 İ	17.04	3.53	KO-1234035 İ	123.40	3.53
KO-0186435 İ	18.64	3.53	KO-1266035 İ	126.60	3.53
KO-0202235 İ	20.22	3.53	KO-1329435 İ	132.94	3.53
KO-0218235 İ	21.82	3.53	KO-1361035 İ	136.10	3.53
KO-0234035 İ	23.40	3.53	KO-1393035 İ	139.30	3.53
KO-0249935 İ	24.99	3.53			

O-RINGS

KASTAŞ NO.	d1	d2	KASTAŞ NO.	d1	d
KO-1424735 İ	142.47	3.53	KO-1020040 İ	102.00	4.00
KO-1488035 İ	148.80	3.53	KO-1050040 İ	105.00	4.00
KO-1520035 İ	151.99	3.53	KO-1060040 İ	106.00	4.00
KO-1550035 İ	155.00	3.53	KO-1080040 İ	108.00	4.00
KO-1583435 İ	158.34	3.53	KO-1100040 İ	110.00	4.00
KO-1520035 İ	151.99	3.53	KO-1120040 İ	112.00	4.00
KO-1710535 İ	171.05	3.53	KO-1180040 İ	118.00	4.00
KO-1773935 İ	177.39	3.53	KO-1200040 İ	120.00	4.00
KO-1901035 İ	190.10	3.53	KO-1220040 İ	122.00	4.00
KO-2027935 İ	202.79	3.53	KO-1250040 İ	125.00	4.00
KO-0100040 İ	10.00	4.00	KO-1300040 İ	130.00	4.00
KO-0120040 İ	12.00	4.00	KO-1320040 İ	132.00	4.00
KO-0140040 İ	14.00	4.00	KO-1350040 İ	135.00	4.00
KO-0160040 İ	16.00	4.00	KO-1450040 İ	145.00	4.00
KO-0180040 İ	18.00	4.00	KO-1550040 İ	155.00	4.00
KO-0200040 İ	20.00	4.00	KO-1700040 İ	170.00	4.00
KO-0220040 İ	22.00	4.00	KO-1900040 İ	190.00	4.00
KO-0230040 İ	23.00	4.00	KO-0200050 İ	20.00	5.00
KO-0240040 İ	24.00	4.00	KO-0250050 İ	25.00	5.00
KO-0250040 İ	25.00	4.00	KO-0300050 İ	30.00	5.00
KO-0260040 İ	26.00	4.00	KO-0330050 İ	33.00	5.00
KO-0270040 İ	27.00	4.00	KO-0350050 İ	35.00	5.00
KO-0280040 İ	28.00	4.00	KO-0400050 İ	40.00	5.00
KO-0300040 İ	30.00	4.00	KO-0450050 İ	45.00	5.00
KO-0310040 İ	31.00	4.00	KO-0500050 İ	50.00	5.00
KO-0320040 İ	32.00	4.00	KO-0520050 İ	52.00	5.00
KO-0340040 İ	34.00	4.00	KO-0550050 İ	55.00	5.00
KO-0350040 İ	35.00	4.00	KO-0600050 İ	60.00	5.00
KO-0360040 İ	36.00	4.00	KO-0650050 İ	65.00	5.00
KO-0380040 İ	38.00	4.00	KO-0700050 İ	70.00	5.00
KO-0400040 İ	40.00	4.00	KO-0750050 İ	75.00	5.00
KO-0410040 İ	41.00	4.00	KO-0780050 İ	78.00	5.00
KO-0420040 İ	42.00	4.00	KO-0800050 İ	80.00	5.00
KO-0430040 İ	43.00	4.00	KO-0850050 İ	85.00	5.00
KO-0440040 İ	44.00	4.00	KO-0900050 İ	90.00	5.00
KO-0450040 İ	45.00	4.00	KO-0950050 İ	95.00	5.00
KO-0470040 İ	47.00	4.00	KO-1000050 İ	100.00	5.00
KO-0480040 İ	48.00	4.00	KO-1050050 İ	105.00	5.00
KO-0500040 İ	50.00	4.00	KO-1100050 İ	110.00	5.00
KO-0520040 İ	52.00	4.00	KO-1150050 İ	115.00	5.00
KO-0540040 İ	54.00	4.00	KO-1200050 İ	120.00	5.00
KO-0550040 İ	55.00	4.00	KO-1250050 İ	125.00	5.00
KO-0560040 İ	56.00	4.00	KO-1300050 İ	130.00	5.00
KO-0570040 İ	57.00	4.00	KO-1400050 İ	140.00	5.00
KO-0580040 İ	58.00	4.00	KO-1500050 İ	150.00	5.00
KO-0600040 İ	60.00	4.00	KO-1550050 İ	155.00	5.00
KO-0620040 İ	62.00	4.00	KO-1600050 İ	160.00	5.00
KO-0650040 İ	65.00	4.00	KO-1650050 İ	165.00	5.00
KO-0660040 İ	66.00	4.00	KO-1800050 İ	180.00	5.00
KO-0670040 İ	67.00	4.00	KO-1850050 İ	185.00	5.00
KO-0680040 İ	68.00	4.00	KO-1900050 İ	190.00	5.00
KO-0700040 İ	70.00	4.00	KO-2000050 İ	200.00	5.00
KO-0720040 İ	72.00	4.00	KO-2100050 İ	210.00	5.00
KO-0730040 İ	73.00	4.00	KO-2200050 İ	220.00	5.00
KO-0750040 İ	75.00	4.00	KO-2250050 İ	225.00	5.00
KO-0780040 İ	78.00	4.00	KO-2400050 İ	240.00	5.00
KO-0800040 İ	80.00	4.00	KO-2750050 İ	275.00	5.00
KO-0820040 İ	82.00	4.00	KO-0184253 İ	18.42	5.33
KO-0840040 İ	84.00	4.00	KO-0199953 İ	19.99	5.33
KO-0850040 İ	85.00	4.00	KO-0231753 İ	23.17	5.33
KO-0900400 İ	90.00	4.00	KO-0263453 İ	26.34	5.33
KO-0920040 İ	92.00	4.00	KO-0295153 İ	29.51	5.33
KO-0950040 İ	95.00	4.00	KO-0326953 İ	32.69	5.33
KO-1000040 İ	100.00	4.00			

O-RINGS

KASTAŞ NO.	d1	d2	KASTAŞ NO.	d1	d
KO-0342953 İ	34.29	5.33	KO-1293057 İ	129.30	5.70
KO-0374753 İ	37.47	5.33	KO-1343057 İ	134.30	5.70
KO-0406553 İ	40.65	5.33	KO-1393057 İ	139.30	5.70
KO-0438253 İ	43.82	5.33	KO-1442057 İ	144.20	5.70
KO-0470053 İ	47.00	5.33	KO-1493057 İ	149.30	5.70
KO-0501653 İ	50.16	5.33	KO-1543057 İ	154.30	5.70
KO-0533453 İ	53.34	5.33	KO-1593057 İ	159.30	5.70
KO-0565253 İ	56.52	5.33	KO-1643057 İ	164.30	5.70
KO-0597053 İ	59.70	5.33	KO-1693057 İ	169.30	5.70
KO-0628753 İ	62.87	5.33	KO-1743057 İ	174.30	5.70
KO-0660453 İ	66.04	5.33	KO-1793057 İ	179.30	5.70
KO-0692253 İ	69.22	5.33	KO-1843057 İ	184.30	5.70
KO-0724053 İ	72.40	5.33	KO-1893057 İ	189.30	5.70
KO-0755753 İ	75.57	5.33	KO-1943057 İ	194.30	5.70
KO-0787453 İ	78.74	5.33	KO-1992057 İ	199.20	5.70
KO-0797753 İ	79.77	5.33	KO-2092057 İ	209.20	5.70
KO-0819253 İ	81.92	5.33	KO-2192057 İ	219.20	5.70
KO-0850953 İ	85.09	5.33	KO-2193057 İ	219.30	5.70
KO-0882753 İ	88.27	5.33	KO-2293057 İ	229.30	5.70
KO-0896953 İ	89.69	5.33	KO-2393057 İ	239.30	5.70
KO-0914453 İ	91.44	5.33	KO-2592057 İ	259.20	5.70
KO-0946253 İ	94.62	5.33	KO-2693057 İ	269.30	5.70
KO-0978053 İ	97.80	5.33	KO-2792057 İ	279.20	5.70
KO-1009753 İ	100.97	5.33	KO-2893057 İ	289.30	5.70
KO-1041453 İ	104.14	5.33	KO-2993057 İ	299.30	5.70
KO-1073253 İ	107.32	5.33	KO-3393057 İ	339.30	5.70
KO-1095453 İ	109.54	5.33	KO-0580699 İ	58.00	6.99
KO-1104953 İ	110.49	5.33	KO-0790070 İ	79.00	6.99
KO-1136753 İ	113.67	5.33	KO-0990070 İ	99.00	6.99
KO-1168453 İ	116.84	5.33	KO-1136769 İ	113.67	6.99
KO-1200253 İ	120.02	5.33	KO-1168469 İ	116.84	6.99
KO-1238053 İ	123.80	5.33	KO-1200699 İ	120.00	6.99
KO-1265753 İ	126.57	5.33	KO-1263769 İ	126.37	6.99
KO-1295453 İ	129.54	5.33	KO-1295469 İ	129.54	6.99
KO-1302053 İ	130.20	5.33	KO-1359069 İ	135.90	6.99
KO-1359053 İ	135.90	5.33	KO-1390769 İ	139.07	6.99
KO-1390753 İ	139.07	5.33	KO-1400699 İ	140.00	6.99
KO-1454253 İ	145.42	5.33	KO-1454269 İ	145.42	6.99
KO-1460553 İ	146.05	5.33	KO-1486069 İ	148.60	6.99
KO-1517753 İ	151.77	5.33	KO-1517769 İ	151.77	6.99
KO-1644753 İ	164.47	5.33	KO-1581269 İ	158.12	6.99
KO-1771753 İ	177.17	5.33	KO-1595069 İ	159.50	6.99
KO-1835253 İ	183.52	5.33	KO-1619699 İ	161.90	6.99
KO-1962253 İ	196.22	5.33	KO-1644769 İ	164.47	6.99
KO-3803753 İ	380.37	5.33	KO-1667069 İ	166.70	6.99
KO-0392057 İ	39.20	5.70	KO-1771769 İ	177.17	6.99
KO-0412057 İ	41.20	5.70	KO-1835269 İ	183.52	6.99
KO-0452057 İ	45.20	5.70	KO-1873069 İ	187.30	6.99
KO-0492057 İ	49.20	5.70	KO-1937069 İ	193.70	6.99
KO-0542057 İ	54.20	5.70	KO-1962269 İ	196.22	6.99
KO-0543057 İ	54.30	5.70	KO-1998069 İ	199.80	6.99
KO-0593057 İ	59.30	5.70	KO-2025769 İ	202.57	6.99
KO-0612057 İ	61.20	5.70	KO-2089269 İ	208.92	6.99
KO-0643057 İ	64.30	5.70	KO-2152769 İ	215.27	6.99
KO-0693057 İ	69.30	5.70	KO-2216269 İ	221.62	6.99
KO-0742057 İ	74.20	5.70	KO-2279769 İ	227.97	6.99
KO-0893057 İ	89.30	5.70	KO-2343269 İ	234.32	6.99
KO-0942057 İ	94.20	5.70	KO-2406769 İ	240.67	6.99
KO-0993057 İ	99.30	5.70	KO-2470069 İ	247.00	6.99
KO-1093057 İ	109.30	5.70	KO-2535769 İ	253.57	6.99
KO-1143057 İ	114.30	5.70	KO-2597069 İ	259.70	6.99
KO-1193057 İ	119.30	5.70	KO-2724069 İ	272.40	6.99
KO-1243057 İ	124.30	5.70	KO-2787769 İ	278.77	6.99



20 horizontal light gray lines for writing.



CHEMICAL RESISTANCE OF RUBBER MATERIALS

Chemical

	°C Test Temperature	NBR	CR	MVQ	FKM	PU	NR	SBR	EPDM	PTFE
Acetaldehyde, with Acetic Acid 90/10%	20	3	3	3	3	5	2	2	2	1
Acetamide	20	4	5	5	5	5	5	5	4	1
Acetic Acid	60	3	3	5	3	3	3	3	2	1
Acetic Acid, Aqueous, 25 to 60 %	60	3	5	5	5	5	3	3	1	1
Acetic Acid, Aqueous, 85 %	100	3	5	5	5	5	3	3	4	1
Acetic Anhydride	20	3	1	5	3	5	2	1	1	1
Acetic Anhydride	80	3	2	5	3	5	3	2	4	1
Acetone	20	3	3	3	3	3	1	1	1	1
Acetylene	60	1	1	1	1	4	1	1	1	1
Acrylic Acid, Ethyl Ester	20	3	5	3	3	3	5	5	4	1
Acrylonitrile	60	3	3	3	3	5	3	3	4	1
Adipic Acid, aqueous	20	1	1	4	1	4	1	1	1	1
Aero Engine Fuels (JP3, JP4, JP5, JP6)	20	1	3	3	1	2	3	3	3	1
Air, oil-containing	80	1	1	1	1	1	3	2	3	1
Air, pure	80	1	1	1	1	1	1	1	1	1
Allyl Alcohol	80	2	2	5	3	3	1	1	1	1
Aluminium Sulphate, Aqueous	60	1	2	4	1	3	1	1	1	1
Ammonia, 100%	20	2	5	5	3	3	1	1	1	1
Ammonia, Aqueous	40	1	5	2	3	3	1	1	1	1
Ammonium Acetate, Aqueous	60	1	2	4	3	3	1	1	1	1
Ammonium Carbonate	60	1	2	4	3	3	1	1	1	1
Ammonium Chloride, Aqueous	60	1	2	4	1	3	1	1	1	1
Ammonium Fluoride, Aqueous	20	1	2	1	1	5	1	1	1	1
Ammonium Nitrate, Aqueous	60	1	2	4	1	3	1	1	1	1
Ammonium Phosphate, Aqueous	60	1	2	4	3	3	1	1	1	1
Ammonium Sulphate	60	1	2	4	1	3	1	1	1	1
Ammonium Sulphide, Aqueous	60	1	2	4	1	3	1	1	1	1
Amyl Acetate	20	3	5	5	3	5	1	3	1	1
Amyl Alcohol	60	2	2	4	3	3	1	1	1	1
Aniline	60	3	3	3	3	3	3	3	5	1
Aniline Hydrochloride	20	2	2	2	1	3	3	3	2	1
Animals Oil, Minerals	80	1	2	1	1	1	3	3	3	1
Anisole	20	3	3	5	5	5	3	3	5	1
Antifreeze	60	1	1	1	1	3	1	1	1	1
Antimony Chloride, Aqueous	20	1	1	1	1	5	1	1	1	1
Antimony Trichloride	60	1	2	5	5	5	1	1	1	1
Arsenic Acid	60	1	2	4	1	3	1	1	1	1
Asphalt	100	5	5	5	4	5	5	5	5	1

1. Excellent 2. Good 3. Not recommended unless necessary 4. Test before using 5. No data available, don't use 6. Please ask for advise

Chemical

	°C Test Temperature	NBR	CR	MVQ	FKM	PU	NR	SBR	EPDM	PTFE
ASTM Fuel A	60	1	2	3	1	1	3	3	3	1
ASTM Fuel B	60	2	3	3	1	3	3	3	3	1
ASTM Fuel C	60	3	3	3	1	3	3	3	3	1
ASTM Oil No: 1	100	1	1	1	1	2	3	3	3	1
ASTM Oil No: 2	100	1	2	1	1	2	3	3	3	1
ASTM Oil No: 3	100	1	2	2	1	2	3	3	3	1
ATE Brake Fluid	100	3	2	1	3	5	1	1	1	1
ATF Oil	100	1	2	2	1	2	3	3	3	1
Barium Hydroxide, Aqueous	60	1	1	4	1	3	1	1	1	1
Barium Salts, Aqueous	60	1	2	1	1	3	1	1	1	1
Beer	20	1	1	1	1	1	1	1	1	1
Benzaldehyde, Aqueous	60	3	3	5	1	3	2	2	2	1
Benzene	20	3	3	3	2	3	3	3	3	1
Benzoic Acid, Aqueous	60	1	2	1	1	3	1	1	1	1
Benzyl Alcohol	60	5	5	2	5	3	4	4	4	1
Blast Furnace gas	100	2	2	1	1	4	3	2	2	1
Bone oil	60	1	3	2	1	1	3	3	3	1
Borax, Aqueous	60	1	2	1	1	3	1	1	1	1
Boric Acid, Aqueous	60	1	2	1	1	3	1	1	1	1
Breake fluids	80	3	2	1	5	5	1	1	1	1
Bromine, Liquid	20	3	3	5	5	5	3	3	4	1
Bromo Benzene	20	5	5	5	4	5	5	5	5	1
Butadiene	60	1	2	2	1	4	3	3	3	1
Butane, Gaseous	20	1	2	4	1	1	3	3	3	1
Butter	20	1	1	1	1	1	5	5	5	1
Butyl Acetate	20	3	3	5	3	5	2	3	2	1
Butyl Alcohol	60	3	2	4	5	3	1	1	1	1
Butyl Phenol	20	3	3	3	2	3	3	3	3	1
Butylene Glycol	60	1	1	1	2	1	1	1	1	1
Butylene, Liquid	20	1	2	4	1	1	3	3	5	1
Butyne Diol	20	1	2	4	2	1	1	1	1	1
Butyraldehyde	20	5	5	5	5	5	2	2	2	1
Butyric Acid, Aqueous	20	1	2	4	1	4	3	4	4	1
Calcium Bisulphite, Aqueous	20	1	1	4	1	1	1	1	1	1
Calcium Chloride, Aqueous	100	1	1	1	1	3	3	1	1	1
Calcium Hydroxide, Aqueous	20	1	1	1	1	3	1	1	1	1
Calcium Hypochlorite, Aqueous	60	3	2	5	2	3	3	3	1	1
Calcium Nitrate, Aqueous	40	1	1	1	1	5	1	1	1	1

1. Excellent 2. Good 3. Not recommended unless necessary 4. Test before using 5. No data available, don't use 6. Please ask for advise

Chemical

	°C Test Temperature	NBR	CR	MVQ	FKM	PU	NR	SBR	EPDM	PTFE
Calcium Phosphate, Aqueous	20	1	1	1	1	4	1	1	1	1
Carbon Dioxide, Dry	60	1	1	1	1	4	1	1	1	1
Carbon Disulphide	20	3	3	3	1	3	3	3	3	1
Carbon Monoxide, Dry	60	1	1	1	1	1	1	1	1	1
Carbon Monoxide, Moist	20	1	1	1	1	5	1	1	1	1
Carbon Tetrachloride	60	3	3	5	1	5	3	3	3	1
Caustic Soda	20	2	2	3	3	5	2	2	1	1
Cellosolve	20	5	5	5	5	5	5	5	2	1
Chloral Hydrate, Aqueous	60	3	3	5	2	5	3	3	2	1
Chloramine, Aqueous	20	1	1	4	5	4	1	1	1	1
Chlorethanol	60	3	3	5	3	5	3	3	2	1
Chloric Acid, Aqueous	80	3	3	5	2	5	3	3	2	1
Chlorine, Dry Gaseous	20	3	3	4	1	4	3	3	1	1
Chlorine, Liquid	20	3	3	5	1	5	3	3	1	1
Chlorine, moist gaseous	20	3	3	5	1	5	3	3	1	1
Chlorobenzene	20	3	3	3	2	4	3	3	3	1
Chlorobromomethane	20	5	5	5	2	5	5	5	2	1
Chloroform	20	3	3	5	2	3	3	3	3	1
Chlorsulphonic Acid	20	3	3	3	5	5	3	3	3	1
Chromic Acid, Aqueous	60	3	3	5	1	5	3	3	4	1
Chromic Acid/Sulphuric Acid/Water 50/15/35%	40	3	3	5	1	5	3	3	4	1
Citric Acid, Aqueous	60	1	2	4	1	5	1	1	1	1
Clophen T 64	100	3	3	2	1	3	3	3	5	1
Clophen-A Types	100	3	3	1	1	3	3	3	5	1
Coconut Fat	80	1	2	1	1	1	3	3	3	1
Coconut Fatty Alcohol	20	1	1	4	1	5	2	2	2	1
Coconut Oil	20	3	3	4	1	1	3	3	3	1
Copper Chloride aqueous	20	1	2	1	1	1	1	1	1	1
Copper Floride aqueous	50	1	2	4	1	5	1	1	1	1
Copper Nitrate, aqueous	60	1	2	4	1	5	1	1	1	1
Copper Sulphate, aqueous	60	1	2	4	1	5	1	1	1	1
Cottonseed Oil	20	1	2	4	1	1	2	2	2	1
Cresol, Aqueous	45	3	3	5	1	1	3	3	3	1
Crotonaldehyde	20	5	5	5	3	4	2	2	1	1
Cyclohexane	20	1	3	2	1	1	3	3	3	1
Cyclohexanol	20	1	3	5	5	1	3	3	3	1
Cyclohexanone	20	3	3	5	5	5	3	3	3	1
Cyclohexylamine	20	3	3	5	3	5	3	3	3	1

1. Excellent 2. Good 3. Not recommended unless necessary 4. Test before using 5. No data available, don't use 6. Please ask for advise

Chemical

	°C Test Temperature	NBR	CR	MVQ	FKM	PU	NR	SBR	EPDM	PTFE
Decalin	20	3	3	5	2	5	3	3	3	1
Decalin	60	3	3	5	2	5	3	3	3	1
Decalin	20	3	3	5	2	5	3	3	3	1
Desmodur T	20	3	3	5	5	2	3	3	3	1
Desmophen 2000	80	1	4	4	4	5	4	1	4	1
Detergent, Synthetic	60	1	2	4	1	4	1	1	1	1
Detergents	100	1	2	5	2	5	3	2	1	1
Diacetone Alcohol	20	2	2	4	5	4	1	1	1	1
Dibenzyl Ether	20	3	3	5	3	5	3	3	2	1
Dibutyl Ether	20	3	3	5	3	5	3	3	2	1
Dibutyl Phthalate	20	3	3	1	1	1	3	3	4	1
Dibutyl Phthalate	60	3	3	1	2	4	3	3	4	1
Dichloroacetic Acid	60	3	3	5	3	3	3	3	1	1
Dichlorethane	20	3	3	3	2	3	3	3	3	1
Dichlorethylene	20	3	3	5	2	5	3	3	5	1
Dichlorobenzene	20	3	3	5	1	5	3	3	3	1
Dichlorobutylene	20	3	3	5	2	5	3	3	3	1
Dichloromethane	20	3	3	3	1	3	3	3	3	1
Diesel Fuel	60	1	2	2	1	2	3	3	3	1
Diethyl Ether	20	3	3	5	3	5	3	3	3	1
Diethylamine	20	2	3	5	3	5	3	3	1	1
Diethylene Glycol	20	1	1	1	1	5	1	1	1	1
Diglycolic Acid, Aqueous	60	2	2	4	1	5	1	1	1	1
Dimethyl Ether	20	3	3	5	3	5	2	3	1	1
Dimethylamine	20	3	3	5	3	5	3	3	1	1
Dimethylformamide	60	3	3	3	3	3	2	3	2	1
Dioxane	60	3	3	5	3	5	2	2	2	1
Dipentene	20	2	3	4	1	4	3	3	3	1
Diphenyl	20	3	3	5	1	4	3	3	3	1
Diphenyl Oxide	100	5	5	5	5	5	5	5	5	1
Disobutyl Ketone	60	3	3	5	3	5	2	3	1	1
Epichlorhydrin	20	5	5	5	3	5	5	5	2	1
Ethane	20	1	2	2	1	1	3	3	3	1
Ethanol	20	1	1	1	6	2	1	1	1	1
Ethanol	60	3	1	4	3	3	1	1	1	1
Ethanol	80	3	3	4	3	3	1	1	1	1
Ethanol with acetic acid (fermentation mixture)	20	3	2	5	3	5	1	1	1	1
Ethanol with acetic acid (fermentation mixture)	60	3	3	5	3	5	1	1	1	1

1. Excellent 2. Good 3. Not recommended unless necessary 4. Test before using 5. No data available, don't use 6. Please ask for advise

Chemical

	°C Test Temperature	NBR	CR	MVQ	FKM	PU	NR	SBR	EPDM	PTFE
Ethyl Acetate	20	3	3	5	3	3	2	2	2	1
Ethyl Acetate	60	3	3	5	3	3	3	3	3	1
Ethyl Acrylate	20	3	5	3	3	5	5	5	4	1
Ethyl Benzene	20	3	3	3	2	4	3	3	3	1
Ethyl Chloride	20	2	2	3	2	2	2	2	2	1
Ethyl Ether	20	3	3	3	3	3	2	3	2	1
Ethylene Chloride	20	2	2	3	2	2	2	2	2	1
Ethylene Diamine	60	3	3	3	3	3	2	2	1	1
Ethylene Glycol	100	1	2	2	1	3	3	1	1	1
Ethylene Trichloride	20	5	5	5	4	5	5	5	5	1
Exhaust Gases, Containing Carbon Dioxide	60	1	1	1	1	4	1	1	1	1
Exhaust Gases, Containing Carbon Monoxide	60	1	1	1	1	1	1	1	1	1
Exhaust Gases, Containing Hydrogen Chloride	60	2	1	4	1	5	1	1	1	1
Exhaust Gases, Containing Hydrogen Fluoride	60	1	1	4	1	5	1	1	1	1
Exhaust Gases, Containing Sulphur Dioxide	60	2	1	4	1	5	2	2	1	1
Exhaust Gases, Containing Sulphuric Acid	60	2	2	4	1	5	2	2	1	1
Exhaust Gases, Containing Sulphuric Acid	80	3	2	4	1	5	2	2	1	1
FAM Test Fuels, DIN 51 604-A	20	1	2	3	1	1	3	3	3	1
FAM Test Fuels, DIN 51 604-C	20	3	3	3	6	3	3	3	3	1
Fats, Mineral, animal or vegetable	80	1	1	1	1	1	3	2	3	1
Fatty Acids	100	2	2	5	1	5	5	5	5	1
Fatty Alcohol	60	20	1	1	1	5	2	2	2	1
Fish Oil	20	1	1	1	1	4	2	2	2	1
Fluorine, Dry	60	3	5	5	5	5	3	5	5	1
Fluorobenzene	20	3	3	3	2	5	3	3	3	1
Fluorocarbon Oils	100	4	4	1	4	4	4	4	4	1
Fluorosilicic Acid	100	4	4	4	4	5	3	4	4	1
Formaldehyde, Aqueous	60	2	2	4	5	5	1	1	1	1
Fruit Juice	100	2	2	1	1	3	3	1	1	1
Furane	20	5	5	5	3	3	5	5	5	1
Furfural	20	3	5	5	5	3	5	5	5	1
Furfuryl Alcohol	20	5	5	5	5	3	5	5	5	1
Furnace gas, dry	60	3	2	1	1	5	1	1	1	1
Gelatine Aqueous	40	1	2	1	1	5	1	1	1	1
Glucose, Aqueous	80	1	2	1	1	5	2	1	1	1
Glycerol Chlorhydrin	60	3	3	5	5	5	2	2	2	1
Glycerol, Aqueous	100	1	2	1	1	5	2	1	1	1
Glycine, Aqueous 10%	40	2	1	4	1	5	2	2	1	1

1. Excellent 2. Good 3. Not recommended unless necessary 4. Test before using 5. No data available, don't use 6. Please ask for advise

Chemical

	°C Test Temperature	NBR	CR	MVQ	FKM	PU	NR	SBR	EPDM	PTFE
Glycolic Acid, Aqueous 37%	20	1	2	1	1	5	1	1	1	1
Grape sugar, Aqueous	80	1	1	1	1	5	3	1	1	1
Heating Oil, Mineral-oil based	60	1	2	2	1	1	3	3	3	1
Heptane	60	1	2	3	1	1	3	3	3	1
Hexachlorobutadiene	20	3	5	5	1	5	3	3	5	1
Hexaldehyde	20	3	3	5	5	5	3	3	5	1
Hexane	60	1	2	3	1	1	3	3	3	1
Hexane Triol	20	1	2	1	1	5	4	4	1	1
Hexene	20	2	2	4	1	1	3	3	3	1
Hydraulic Fluids, Type HFA	55	1	2	4	1	5	3	3	3	1
Hydraulic Fluids, Type HFB	60	6	2	4	1	5	3	3	3	1
Hydraulic Oils, DIN 51 524	80	1	2	2	1	1	3	3	3	1
Hydrazine Hydrate	20	2	2	5	5	2	3	2	1	1
Hydrobromic Acid, Aqueous	60	2	2	5	5	3	4	4	1	1
Hydrochloric Acid (adquate)	80	3	3	5	1	5	3	3	1	1
Hydrochloric Acid, Concentrated	20	3	3	5	1	5	2	2	1	1
Hydrochloric Acid, Dilute	20	1	2	5	1	3	1	1	1	1
Hydrocyanic Acid	20	4	2	1	4	5	4	4	4	1
Hydrogen	20	1	1	1	1	5	1	1	1	1
Hydrogen Chloride Gas	60	3	3	5	1	5	2	2	1	1
Hydrogen Peroxide, Aqueous	20	3	3	2	1	5	3	3	1	1
Hydrogen Sulphide, Aqueous	60	2	2	5	1	5	2	1	1	1
Hydrogen Sulphide, dry	60	2	2	4	1	4	2	2	1	1
Hydrosulphite Aqueous	40	2	2	4	5	5	1	1	1	1
Hydroxylamine Sulphate, Aqueous	35	1	2	1	5	5	1	1	1	1
Ink	20	1	1	1	2	1	1	1	1	1
Iodoform	20	5	5	5	1	5	5	5	1	1
Iron 3 chloride, Aqueous	40	1	1	4	1	4	1	1	1	1
Isobutanol	20	2	1	1	1	3	1	1	1	1
Isooctane	20	1	2	2	1	2	3	3	3	1
Isophorone	20	4	4	4	4	2	4	4	1	1
Isopropanol	60	2	2	1	2	5	1	2	1	1
Isopropyl Acetate	80	3	3	3	3	5	3	3	2	1
Isopropyl Chloride	20	3	3	3	1	3	3	3	3	1
Isopropyl Ether	60	3	3	3	3	3	5	3	5	1
Kerosene	20	1	3	2	1	1	3	3	3	1
Lactam	80	3	3	5	3	5	3	3	3	1
Lactic Acid, Aqueous	40	1	1	4	1	1	1	1	1	1

1. Excellent 2. Good 3. Not recommended unless necessary 4. Test before using 5. No data available, don't use 6. Please ask for advise

Chemical	°C Test Temperature	NBR	CR	IMVQ	FKM	PU	NR	SBR	EPDM	PTFE
Heating Oil, Mineral-oil based	60	1	2	2	1	1	3	3	3	1
Heptane	60	1	2	3	1	1	3	3	3	1
Hexachlorobutadiene	20	3	5	5	1	5	3	3	5	1
Hexaldehyde	20	3	3	5	5	5	3	3	5	1
Hexane	60	1	2	3	1	1	3	3	3	1
Hexane Triol	20	1	2	1	1	5	4	4	1	1
Hexene	20	2	2	4	1	1	3	3	3	1
Hydraulic Fluids, Type HFA	55	1	2	4	1	5	3	3	3	1
Hydraulic Fluids, Type HFB	60	6	2	4	1	5	3	3	3	1
Hydraulic Oils, DIN 51 524	80	1	2	2	1	1	3	3	3	1
Hydrazine Hydrate	20	2	2	5	5	2	3	2	1	1
Hydrobromic Acid, Aqueous	60	2	2	5	5	3	4	4	1	1
Hydrochloric Acid (adquate)	80	3	3	5	1	5	3	3	1	1
Hydrochloric Acid, Concentrated	20	3	3	5	1	5	2	2	1	1
Hydrochloric Acid, Dilute	20	1	2	5	1	3	1	1	1	1
Hydrocyanic Acid	20	4	2	1	4	5	4	4	4	1
Hydrogen	20	1	1	1	1	5	1	1	1	1
Hydrogen Chloride Gas	60	3	3	5	1	5	2	2	1	1
Hydrogen Peroxide, Aqueous	20	3	3	2	1	5	3	3	1	1
Hydrogen Sulphide, Aqueous	60	2	2	5	1	5	2	1	1	1
Hydrogen Sulphide, dry	60	2	2	4	1	4	2	2	1	1
Hydrosulphite Aqueous	40	2	2	4	5	5	1	1	1	1
Hydroxylamine Sulphate, Aqueous	35	1	2	1	5	5	1	1	1	1
Ink	20	1	1	1	2	1	1	1	1	1
Iodoform	20	5	5	5	1	5	5	5	1	1
Iron 3 chloride, Aqueous	40	1	1	4	1	4	1	1	1	1
Isobutanol	20	2	1	1	1	3	1	1	1	1
Isooctane	20	1	2	2	1	2	3	3	3	1
Isophorone	20	4	4	4	4	2	4	4	1	1
Isopropanol	60	2	2	1	2	5	1	2	1	1
Isopropyl Acetate	80	3	3	3	3	5	3	3	2	1
Isopropyl Chloride	20	3	3	3	1	3	3	3	3	1
Isopropyl Ether	60	3	3	3	3	3	5	3	5	1
Kerosene	20	1	3	2	1	1	3	3	3	1
Lactam	80	3	3	5	3	5	3	3	3	1
Lactic Acid, Aqueous	40	1	1	4	1	1	1	1	1	1
Lanolin	60	1	2	1	1	1	2	2	3	1
Lauryl Alcohol	20	1	1	4	1	4	2	2	2	1

1. Excellent 2. Good 3. Not recommended unless necessary 4. Test before using 5. No data available, don't use 6. Please ask for advise

Chemical

	°C Test Temperature	NBR	CR	MVQ	FKM	PU	NR	SBR	EPDM	PTFE
Monochloroacetic Acid, ethyl ester	60	2	2	5	5	3	3	3	1	1
Morpholine	60	3	3	4	5	5	3	3	2	1
Motor oil	100	1	2	2	1	2	3	3	3	1
Naphtha	20	3	3	5	1	3	5	5	5	1
Naphthalene	60	3	3	5	1	5	3	3	3	1
Naphthoic Acid	20	2	4	5	1	5	5	5	5	1
Natural Gas	20	1	1	1	1	2	3	3	5	1
Nickel Acetate, Aqueous	20	1	2	4	4	3	1	1	1	1
Nickel Chloride, Aqueous	20	1	2	4	1	5	1	1	1	1
Nickel Sulphate, Aqueous	60	1	2	4	1	5	1	1	1	1
Nitric Acid, concentrated	80	3	3	5	3	3	3	3	3	1
Nitrous Oxide	20	1	1	1	1	1	1	1	1	1
Nitrobenzene	60	3	3	3	3	3	3	3	3	1
Nitrogen Dioxide	20	5	5	3	5	5	5	5	3	1
Nitroglycerine	20	3	5	5	1	5	2	2	1	1
Nitroglycol, Aqueous	20	3	2	4	1	4	4	4	1	1
Nitromethane	20	3	5	3	3	3	2	2	2	1
Nitroporopane	20	3	3	3	3	3	2	2	2	1
Niytrogen	20	1	1	1	1	1	1	1	1	1
n-Propanol	60	2	2	1	2	3	1	1	1	1
Octane	20	4	5	5	1	4	5	5	5	1
Octyl Alcohol	20	2	1	2	1	5	2	2	1	1
Octyl Cresol	20	5	3	3	2	5	3	3	3	1
Oleum, %10	20	3	3	3	1	3	3	3	2	1
Olive Oil	60	1	1	1	1	4	2	2	2	1
O-Nitrotoluene	60	3	3	3	3	5	3	3	3	1
Oxalic Acid, Aqueous	100	3	3	5	1	5	3	2	1	1
Ozone	20	5	2	1	1	4	5	5	1	1
Paraffin	60	1	1	4	1	4	3	3	3	1
Paraffin Emulsions	40	1	1	1	1	1	3	3	3	1
Paraffin Oil	60	1	1	1	1	1	3	3	3	1
Pectin	20	1	1	1	1	1	1	1	1	1
Pentachlorodiphenyl	60	3	3	5	5	5	3	3	3	1
Pentane	20	1	2	4	1	4	3	3	3	1
Perchlorethylene	60	3	3	3	1	5	3	3	3	1
Perchloric Acid	100	3	3	5	1	5	3	3	1	1
Petrol	60	1	2	3	1	1	3	3	3	1
Petrol / Benzene mixture 50/50%	20	3	3	3	1	2	3	3	3	1

1. Excellent 2. Good 3. Not recommended unless necessary 4. Test before using 5. No data available, don't use 6. Please ask for advise

Chemical

	°C Test Temperature	NBR	CR	MVQ	FKM	PU	NR	SBR	EPDM	PTFE
Petrol / Benzene mixture 60/40%	20	3	3	3	1	2	3	3	3	1
Petrol / Benzene mixture 70/30%	20	2	3	3	1	1	3	3	3	1
Petrol / Benzene mixture 80/20%	20	2	3	3	1	1	3	3	3	1
Petrol / Benzene/Ethanol 50/30/20%	20	3	3	3	2	3	3	3	3	1
Phenol, aqueous up to 90%	80	3	3	5	2	5	3	3	3	1
Phenyl benzene	20	3	3	5	2	5	3	3	3	1
Phenyl ethyl ether	20	3	3	3	3	3	3	3	3	1
Phenyl Hydrazine	60	2	3	5	2	5	3	3	3	1
Phenylhydrazine chlorhydrate aqueous	80	2	3	5	2	5	3	3	1	1
Phosphoric Acid Esther HFD	80	3	3	3	6	3	3	3	6	1
Phosphoric Acid, Aqueous	60	3	2	5	1	5	2	1	1	1
Phosphorus Trichloride	20	3	3	5	2	5	1	4	1	1
Photographic Emulsions	20	1	1	4	1	5	1	1	1	1
Photographic Fixing Baths	40	1	1	4	1	5	1	1	1	1
Phthalic acid, aqueous	60	1	2	4	1	5	3	4	1	1
Picric Acid	20	2	1	5	1	2	2	2	2	1
Picric Acid, Aqueous	20	1	2	1	1	5	1	1	1	1
Piperidine	20	5	5	5	5	5	5	5	5	1
Polyglycol-water emulsions	60	1	2	1	1	5	1	1	1	1
Potassium Acetate, Aqueous	20	1	2	4	1	2	1	1	1	1
Potassium Bisulphate, Aqueous	40	1	2	4	1	3	1	1	1	1
Potassium Borate, Aqueous	60	1	2	4	1	3	1	1	1	1
Potassium Bormate, %10	60	1	2	4	1	3	1	1	1	1
Potassium Bromide, Aqueous	60	1	2	4	1	3	1	1	1	1
Potassium Carbonate, Aqueous	40	1	2	1	1	5	1	1	1	1
Potassium Chlorate, Aqueous	60	3	2	4	1	3	2	2	1	1
Potassium Chromate, Aqueous	20	2	2	4	1	3	1	1	1	1
Potassium Cyanide, Aqueous	40	1	2	1	1	4	1	1	1	1
Potassium Cyanide, Aqueous	80	2	2	1	1	3	3	3	1	1
Potassium Dichromate, Aqueous 40%	20	2	2	4	1	5	3	2	1	1
Potassium Iodide, Aqueous	60	1	2	4	1	3	2	1	1	1
Potassium Nitrate, Aqueous	60	1	2	4	1	3	1	1	1	1
Potassium Perchlorate, Aqueous	80	3	2	4	1	5	3	3	1	1
Potassium Permanganate, Aqueous	40	3	2	5	1	5	3	2	1	1
Potassium Persulphate, Aqueous	60	3	3	5	1	5	3	2	1	1
Potassium Sulphate, Aqueous	60	1	2	4	1	5	1	1	1	1
Propane, Liquid Gaseous	20	1	1	1	1	1	3	3	5	1
Propionic Acid, Aqueous	60	1	2	5	1	5	5	4	4	1

1. Excellent 2. Good 3. Not recommended unless necessary 4. Test before using 5. No data available, don't use 6. Please ask for advise

Chemical	°C Test Temperature	NBR	CR	VMQ	FKM	PU	NR	SBR	EPDM	PTFE
Propylene Glycol	60	1	2	4	1	5	1	1	1	1
Propylene Oxide	20	3	5	5	5	5	5	5	5	1
Refrigerant according to DIN 8962 R 11	20	1	2	5	2	5	5	5	5	1
Refrigerant according to DIN 8962 R 113	20	1	1	5	2	2	5	5	5	1
Refrigerant according to DIN 8962 R 114	20	1	1	5	4	1	1	1	1	1
Refrigerant according to DIN 8962 R 12	20	1	1	5	2	1	2	2	2	1
Refrigerant according to DIN 8962 R 13	20	1	1	5	2	2	5	1	1	1
Refrigerant according to DIN 8962 R 134a	20	2	1	5	3	5	5	5	1	1
Refrigerant according to DIN 8962 R 22	20	3	1	5	3	2	1	1	1	1
Salicylic Acid	20	1	1	5	1	1	1	1	1	1
Salt Water	20	1	1	5	1	5	1	1	1	1
Sea Water	20	1	2	1	1	2	1	1	1	1
Silicic Acid, Aqueous	60	1	2	5	1	5	1	1	1	1
Silicone Grease	20	1	1	3	1	1	1	1	1	1
Silicone Oil	20	1	1	1	1	1	3	1	1	1
Silver Nitrate, Aqueous	100	2	2	4	1	5	5	2	1	1
Silver Salts, Aqueous	60	2	2	1	1	5	2	2	1	1
Soap Solution, Aqueous	20	1	2	4	1	1	1	1	1	1
Soda, Aqueous	60	1	2	1	1	5	1	1	1	1
Sodium Benzoate, Aqueous	40	1	2	4	1	4	1	1	1	1
Sodium Bicarbonate, Aqueous	60	1	2	4	1	5	1	1	1	1
Sodium Bisulphite, Aqueous	100	1	2	4	1	5	1	1	1	1
Sodium Chlorate	20	3	3	4	1	5	3	3	1	1
Sodium Chloride	100	1	2	4	1	5	5	1	1	1
Sodium Hypochlorite, Aqueous	20	2	2	4	1	5	3	3	1	1
Sodium Nitrate, Aqueous	60	1	2	4	1	5	1	1	1	1
Sodium Nitrite	60	2	2	4	1	5	1	1	1	1
Sodium Phosphate, Aqueous	60	1	2	4	1	5	1	1	1	1
Sodium Silicate, Aqueous	60	1	2	4	1	5	1	1	1	1
Sodium Sulphate	20	1	2	4	1	5	1	1	1	1
Sodium Sulphate, Aqueous	60	1	2	4	1	5	1	1	1	1
Sodium Sulphide	40	1	2	4	1	5	1	1	1	1
Starch, Aqueous	60	1	1	1	1	3	1	1	1	1
Stearic Acid	60	1	2	1	1	1	3	1	1	1
Sugar Syrup	60	1	5	4	1	5	1	4	1	1
Sulphur	60	5	5	4	1	4	5	5	1	1
Sulphur Chloride	20	3	3	5	1	5	5	5	5	1
Sulphur dioxide, aqueous	60	3	3	5	1	5	3	2	1	1

1. Excellent 2. Good 3. Not recommended unless necessary 4. Test before using 5. No data available, don't use 6. Please ask for advise

Chemical

	°C Test Temperature	NBR	CR	MVQ	FKM	PU	NR	SBR	EPDM	PTFE
Sulphur dioxide, dry	80	3	3	4	1	5	3	2	1	1
Sulphur dioxide, liquid	60	3	3	5	1	5	3	5	1	1
Sulphur Hexafluoride	20	1	1	1	1	4	4	1	1	1
Sulphuric acid / nitric acid / water	20	3	2	3	1	3	3	3	1	1
Sulphuric acid / phosphoric acid / water	40	3	3	5	1	5	2	2	1	1
Sulphuric Acid, concentrated	50	3	3	3	1	3	3	2	1	1
Sulphuric Acid, dilute	20	2	3	5	1	5	2	2	1	1
Sulphuryl Chloride	20	3	3	5	1	5	2	2	2	1
Tannic Acid	60	1	2	1	1	5	1	1	1	1
Tar	20	3	3	5	4	5	3	3	3	1
Tar oil	20	3	3	5	4	5	3	3	3	1
Tartaric Acid, Aqueous	60	1	2	1	1	5	1	1	1	1
Tetrachlorethane	60	3	3	5	2	5	3	3	3	1
Tetrachlorethylene	60	3	3	5	2	5	3	3	3	1
Tetraethyl Lead	20	2	3	5	1	5	5	5	5	1
Tetrahydrofuran	20	3	3	5	3	5	3	3	3	1
Tetrahydronaphthalene (tetralin)	20	3	3	5	1	5	3	3	3	1
Thionyl Chloride	20	3	3	5	1	5	2	2	1	1
Thiophene	60	3	3	5	3	5	3	3	3	1
Tin 2 Chloride, Aqueous	80	1	2	4	1	5	1	1	1	1
Titanium Tetrachloride	20	1	2	2	2	1	1	1	1	1
Toluene	20	3	3	3	2	3	3	3	3	1
Transmission fluid, Type A	60	1	3	2	1	1	3	3	3	1
Triacetin	20	2	2	5	5	5	2	3	1	1
Tributoxyethyl Phosphate	20	3	3	5	2	5	3	3	3	1
Tributyl Phosphate	60	3	3	5	2	3	3	3	3	1
Trichloroacetic Acid, Aqueous	60	2	3	5	3	5	2	2	2	1
Trichlorethyl Phosphate	20	3	3	5	3	5	5	5	5	1
Trichlorethylene	20	3	3	3	2	3	3	3	3	1
Tricresyl Phosphate	60	3	3	5	2	2	3	3	2	1
Triethanolamine	20	3	2	5	5	5	3	4	2	1
Triethyl aluminium	20	5	5	5	2	1	1	1	1	1
Triethyl Borane	20	5	5	5	1	5	5	5	5	1
Triglycol	20	1	1	4	1	4	1	1	1	1
Trimethylol Propane, Aqueous	100	3	2	4	1	5	2	4	2	1
Trinitrotoluene	20	5	2	5	2	5	5	5	5	1
Trioctyl Phosphate	60	3	3	5	2	5	3	5	2	1
Trisodium Phosphate	20	1	2	1	1	4	1	1	1	1

1. Excellent 2. Good 3. Not recommended unless necessary 4. Test before using 5. No data available, don't use 6. Please ask for advise



20 horizontal light gray lines for writing.



KASTAS SEALING TECHNOLOGIES A.S.

Atatürk Organize Sanayi Bölgesi, 10001 Sokak, No. 19 35620 Çiğli - İZMİR / TURKEY • Tel. +90 232 376 88 26 • Fax. +90 232 376 87 57
www.kastas.com • info@kastas.com.tr

KASTAS SEALING TECHNOLOGIES EUROPE GmbH

Robert-Bosch-Str 11-13, 25451 Quickborn/GERMANY
Tel. +49 4106 809 280 • Fax. +49 4106 809 28 49
www.kastas.com • europe@kastas.com.tr



www.kastas.com